



# Mạng hai cửa

Cơ sở lý thuyết mạch điện

## Nội dung

- Thông số mạch
- Phân tử mạch
- Mạch một chiều
- Mạch xoay chiều
- **Mạng hai cửa**
- Mạch ba pha
- Quá trình quá độ

## Giới thiệu (1)

- Cửa: một cặp điểm, dòng điện chạy vào một điểm và đi ra khỏi điểm kia
- Các phần tử cơ bản, mạng Thevenin & Norton: mạng một cửa
- **Mạng hai cửa**: mạng điện có 2 cửa riêng biệt
- Mạng hai cửa còn gọi là mạng bốn cực
- Nghiên cứu mạng hai cửa vì:
  - Phổ biến trong viễn thông, điều khiển, hệ thống điện, điện tử, ...
  - Khi biết được các thông số của một mạng hai cửa, ta sẽ coi nó như một “hộp đen” → rất thuận tiện khi nó được nhúng trong một mạng lớn hơn

## Giới thiệu (2)

- Xét mạng hai cửa với nguồn kích thích xoay chiều
- Đặc trưng của một mạng hai cửa là một bộ thông số
- Bộ thông số này liên kết 4 đại lượng  $\dot{U}_1, \dot{I}_1, \dot{U}_2, \dot{I}_2$ , trong đó có 2 đại lượng độc lập
- Có 6 bộ (thông) số:

- $Z$
- $Y$
- $H$
- $G$
- $A$
- $B$

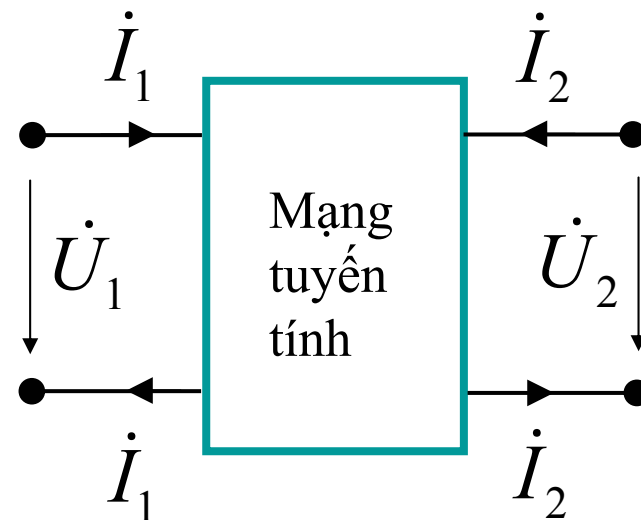



## Giới thiệu (3)

- 2 bài toán chính:
  - Tính bộ thông số của mạng hai cửa
  - Phân tích mạch có mạng hai cửa (đã cho sẵn bộ thông số)

# Mạng hai cửa

- Các bộ thông số
  - $Z$
  - $Y$
  - $H$
  - $G$
  - $A$
  - $B$
- Quan hệ giữa các bộ thông số
- Phân tích mạch có mạng hai cửa
- Kết nối các mạng hai cửa
- Mạng T & Π
- Tương hỗ
- Tổng trở vào & hoà hợp tải
- Hàm truyền đạt



## Z (1)

- Còn gọi là bộ số tổng trở
- Thường được dùng trong:
  - Tổng hợp các bộ lọc
  - Phối hợp trở kháng
  - Mạng lưới truyền tải điện

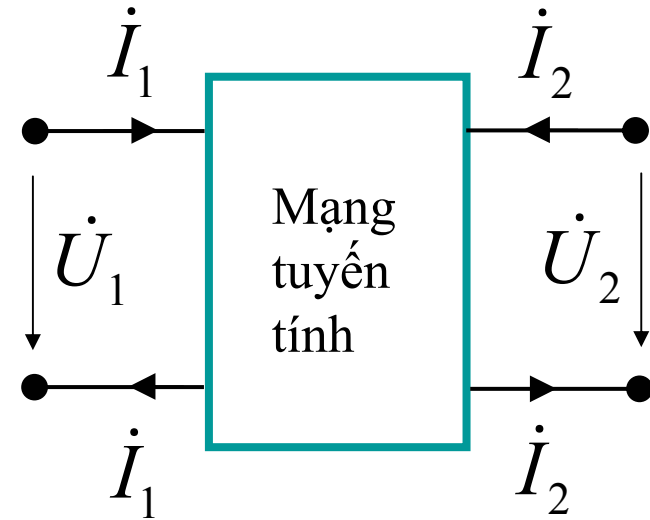

$$\begin{cases} \dot{U}_1 = Z_{11}\dot{I}_1 + Z_{12}\dot{I}_2 \\ \dot{U}_2 = Z_{21}\dot{I}_1 + Z_{22}\dot{I}_2 \end{cases} \Leftrightarrow \begin{bmatrix} \dot{U}_1 \\ \dot{U}_2 \end{bmatrix} = \begin{bmatrix} Z_{11} & Z_{12} \\ Z_{21} & Z_{22} \end{bmatrix} \begin{bmatrix} \dot{I}_1 \\ \dot{I}_2 \end{bmatrix} = [Z] \begin{bmatrix} \dot{I}_1 \\ \dot{I}_2 \end{bmatrix}$$



## Z (2)

$$\left. \begin{cases} \dot{U}_1 = Z_{11}\dot{I}_1 + Z_{12}\dot{I}_2 \\ \dot{U}_2 = Z_{21}\dot{I}_1 + Z_{22}\dot{I}_2 \end{cases} \right\} \begin{matrix} \rightarrow \\ \\ \end{matrix} \left. \begin{cases} \dot{U}_1 = Z_{11}\dot{I}_1 \\ \dot{U}_2 = Z_{21}\dot{I}_1 \end{cases} \right\} \begin{matrix} \rightarrow \\ \\ \end{matrix} \left. \begin{cases} Z_{11} = \frac{\dot{U}_1}{\dot{I}_1} = \frac{\dot{U}_1}{\dot{I}_1} \Big|_{\dot{I}_2=0} \\ Z_{21} = \frac{\dot{U}_2}{\dot{I}_1} = \frac{\dot{U}_2}{\dot{I}_1} \Big|_{\dot{I}_2=0} \end{cases} \right.$$

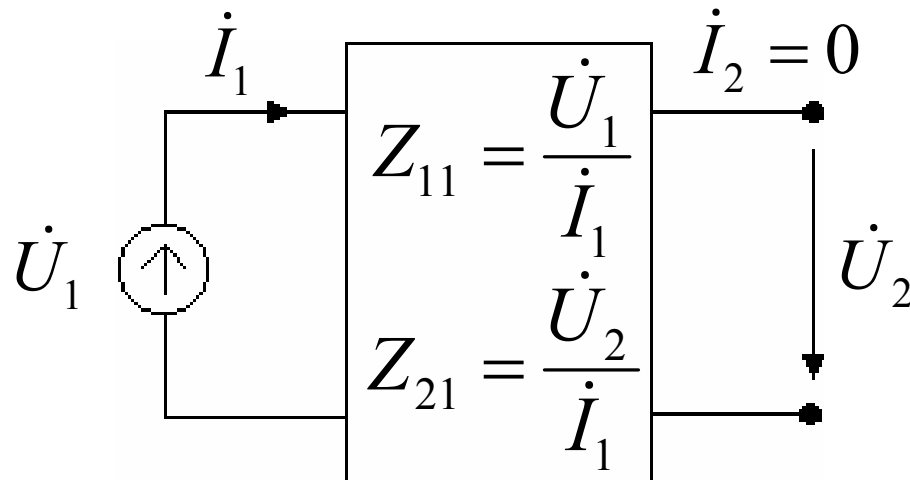





# Z (3)

$$\left. \begin{cases} \dot{U}_1 = Z_{11}\dot{I}_1 + Z_{12}\dot{I}_2 \\ \dot{U}_2 = Z_{21}\dot{I}_1 + Z_{22}\dot{I}_2 \end{cases} \right\} \begin{matrix} \dot{I}_1 = 0 \\ \end{matrix} \rightarrow \begin{cases} \dot{U}_1 = Z_{12}\dot{I}_2 \\ \dot{U}_2 = Z_{22}\dot{I}_2 \end{cases} \rightarrow \begin{cases} Z_{12} = \frac{\dot{U}_1}{\dot{I}_2} = \frac{\dot{U}_1}{\dot{I}_2} \Big|_{\dot{I}_1=0} \\ Z_{22} = \frac{\dot{U}_2}{\dot{I}_2} = \frac{\dot{U}_2}{\dot{I}_2} \Big|_{\dot{I}_1=0} \end{cases}$$

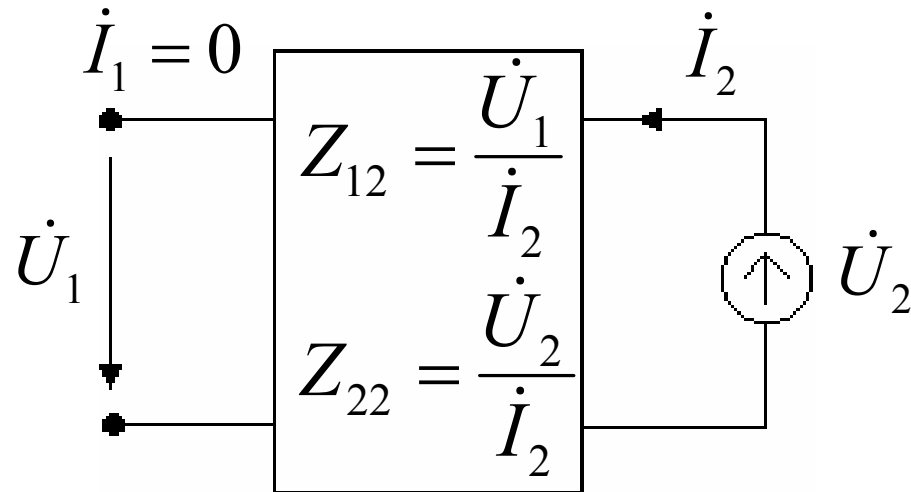

Mạng hai cửa



# Z (4)

$$\begin{cases} \dot{U}_1 = Z_{11}\dot{I}_1 + Z_{12}\dot{I}_2 \\ \dot{U}_2 = Z_{21}\dot{I}_1 + Z_{22}\dot{I}_2 \end{cases}$$

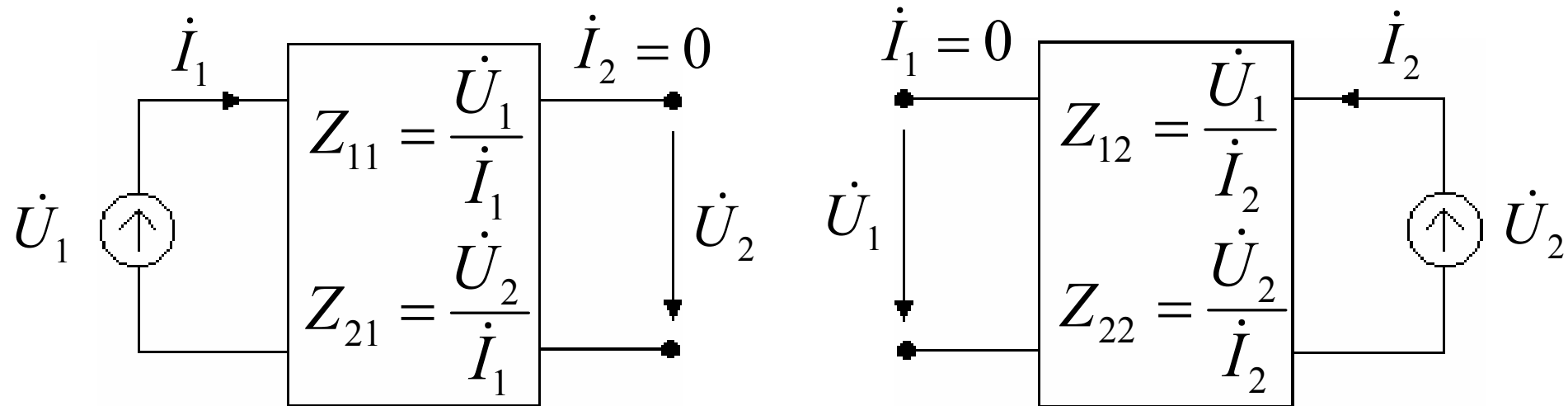

## $Z(5)$

- Nếu  $Z_{11} = Z_{22}$  : mạng hai cửa đối xứng
- Nếu  $Z_{12} = Z_{21}$  : mạng hai cửa tương hỗ
- Có một số mạng hai cửa không có bộ số  $Z$



**VD1**

**Z (6)**

$R_1 = 10 \Omega; R_2 = 20 \Omega; R_3 = 30 \Omega; \text{Tính bộ số } Z.$

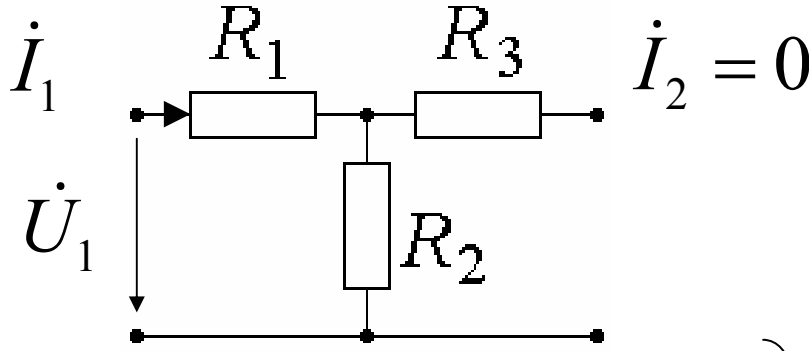

$$Z_{11} = \left. \frac{\dot{U}_1}{\dot{I}_1} \right|_{\dot{I}_2=0}$$

$$\dot{U}_1 = (R_1 + R_2)\dot{I}_1 = (10 + 20)\dot{I}_1 = 30\dot{I}_1$$

$$\rightarrow Z_{11} = \frac{\dot{U}_1}{\dot{I}_1} = \frac{30\dot{I}_1}{\dot{I}_1} = 30\Omega$$

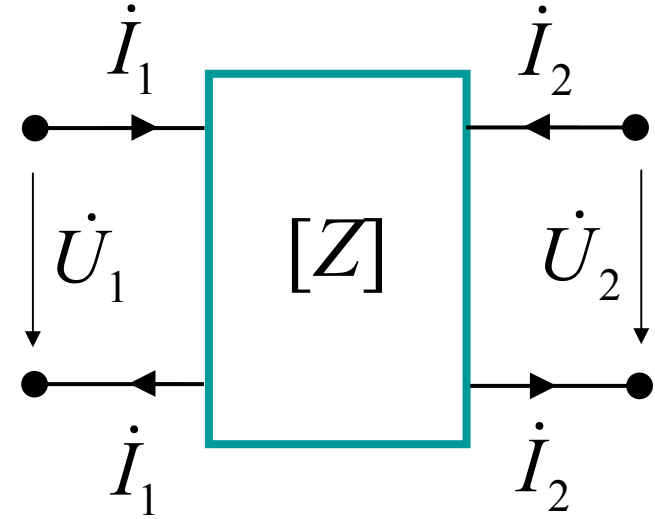
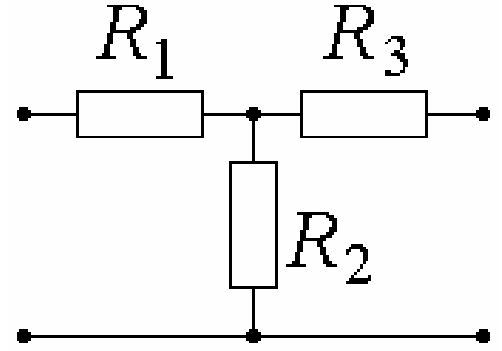

$$\begin{cases} \dot{U}_1 = Z_{11}\dot{I}_1 + Z_{12}\dot{I}_2 \\ \dot{U}_2 = Z_{21}\dot{I}_1 + Z_{22}\dot{I}_2 \end{cases}$$



**VD1**

**Z (7)**

$R_1 = 10 \Omega; R_2 = 20 \Omega; R_3 = 30 \Omega; \text{Tính bộ số } Z.$

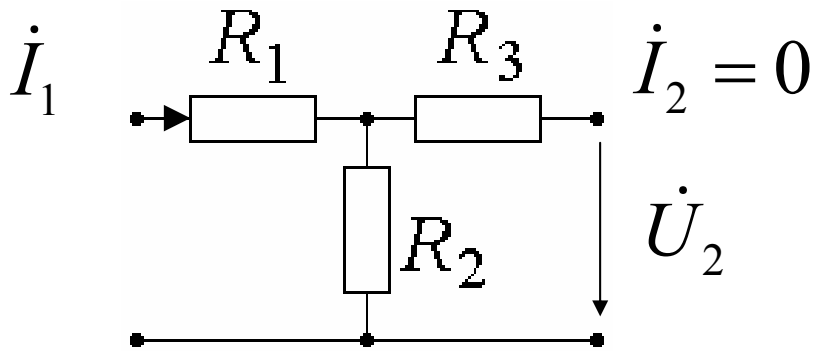

$$Z_{21} = \left. \frac{\dot{U}_2}{\dot{I}_1} \right|_{\dot{I}_2=0}$$

$$\dot{U}_2 = R_2 \dot{I}_1 = 20 \dot{I}_1$$

$$\rightarrow Z_{21} = \frac{\dot{U}_2}{\dot{I}_1} = \frac{20 \dot{I}_1}{\dot{I}_1} = 20 \Omega$$

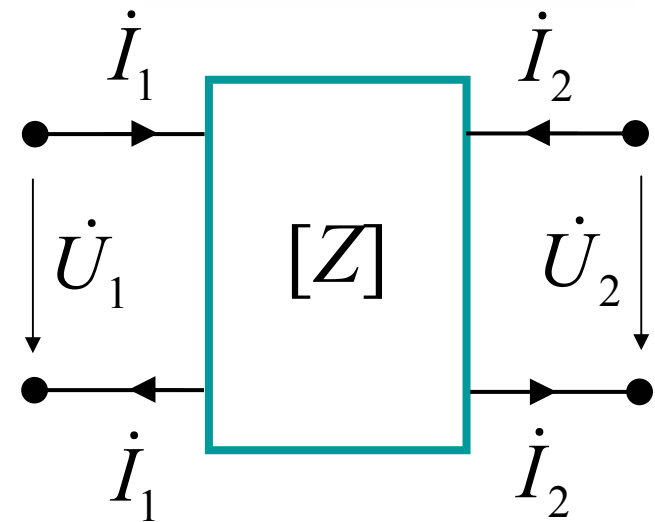
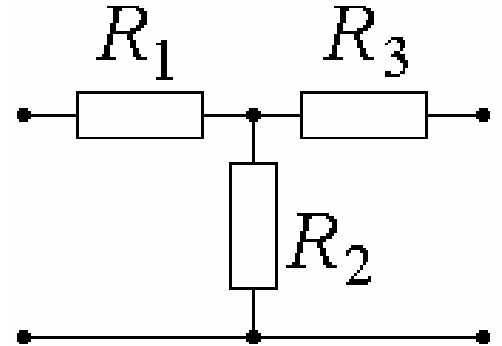

$$\begin{cases} \dot{U}_1 = Z_{11} \dot{I}_1 + Z_{12} \dot{I}_2 \\ \dot{U}_2 = Z_{21} \dot{I}_1 + Z_{22} \dot{I}_2 \end{cases}$$



**VD1**

**Z (8)**

$R_1 = 10 \Omega; R_2 = 20 \Omega; R_3 = 30 \Omega$ ; Tính bộ số Z.

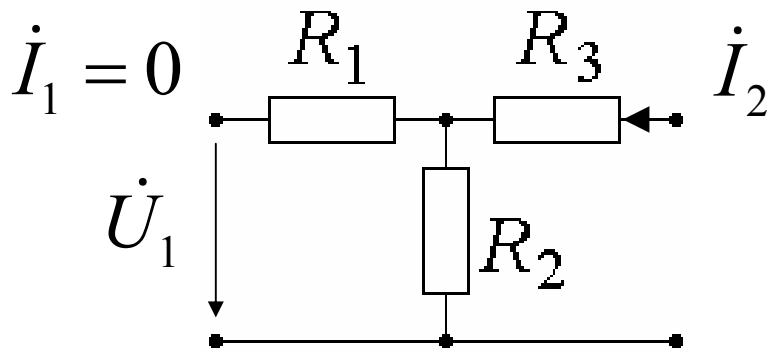

$$Z_{12} = \left. \frac{\dot{U}_1}{\dot{I}_2} \right|_{\dot{I}_1=0}$$

$$\dot{U}_1 = R_2 \dot{I}_2 = 20 \dot{I}_2$$

$$\rightarrow Z_{12} = \frac{\dot{U}_1}{\dot{I}_2} = \frac{20 \dot{I}_2}{\dot{I}_2} = 20 \Omega$$

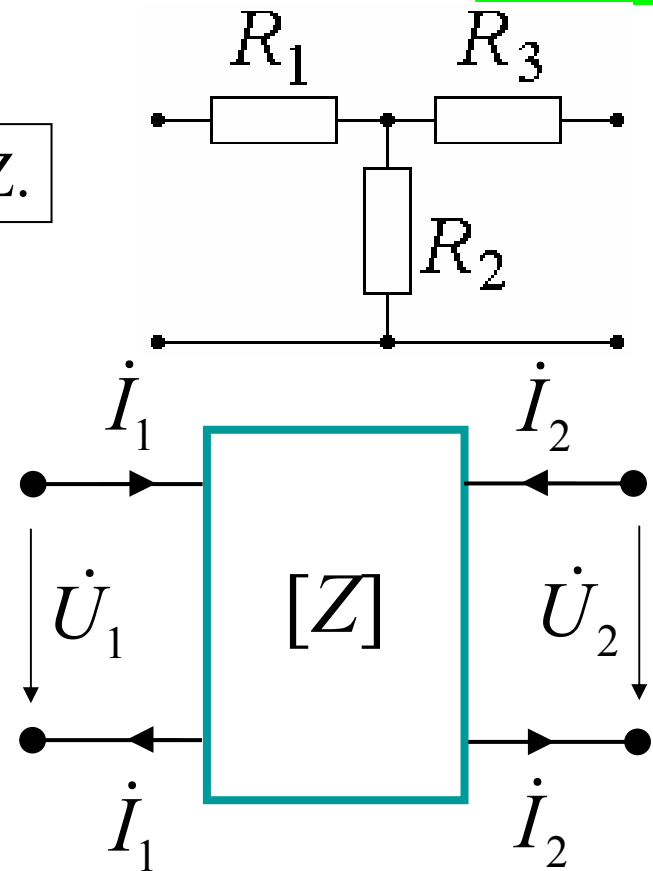

$$\begin{cases} \dot{U}_1 = Z_{11} \dot{I}_1 + Z_{12} \dot{I}_2 \\ \dot{U}_2 = Z_{21} \dot{I}_1 + Z_{22} \dot{I}_2 \end{cases}$$



**VD1**

**Z (9)**

$R_1 = 10 \Omega; R_2 = 20 \Omega; R_3 = 30 \Omega; \text{Tính bộ số } Z.$

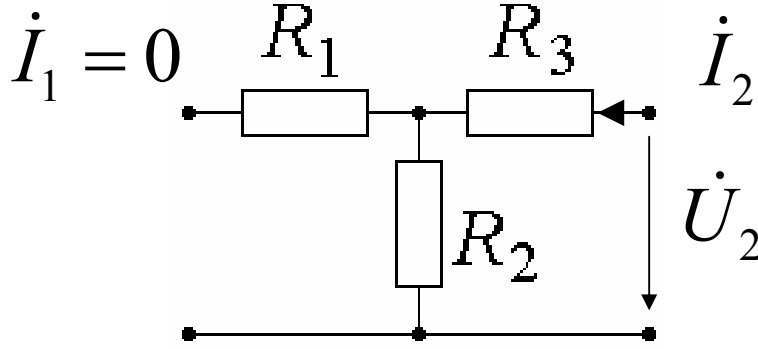

$$Z_{22} = \left. \frac{\dot{U}_2}{\dot{I}_2} \right|_{\dot{I}_1=0}$$

$$\dot{U}_2 = (R_2 + R_3)\dot{I}_2 = (20 + 30)\dot{I}_2 = 50\dot{I}_2$$

$$\rightarrow Z_{22} = \frac{\dot{U}_2}{\dot{I}_2} = \frac{50\dot{I}_2}{\dot{I}_2} = 50\Omega$$

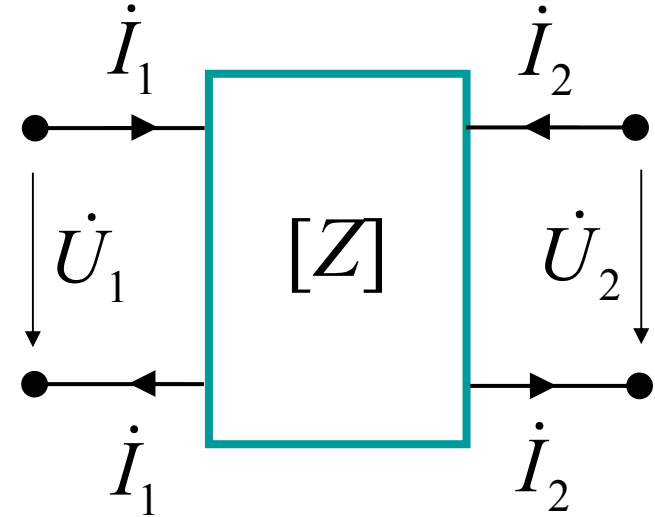
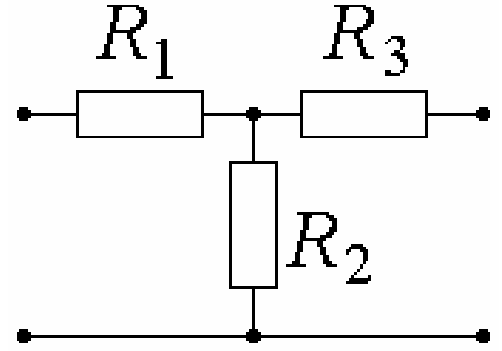

$$\begin{cases} \dot{U}_1 = Z_{11}\dot{I}_1 + Z_{12}\dot{I}_2 \\ \dot{U}_2 = Z_{21}\dot{I}_1 + Z_{22}\dot{I}_2 \end{cases}$$



**VD1**

**Z (10)**

$R_1 = 10 \Omega; R_2 = 20 \Omega; R_3 = 30 \Omega; \text{Tính bộ số } Z.$

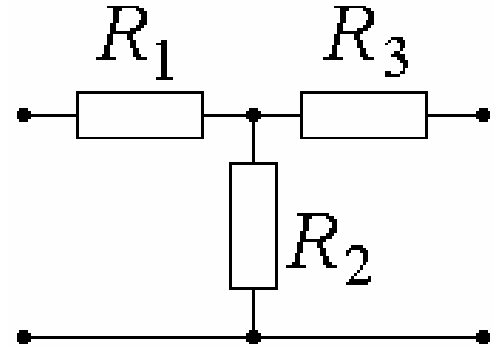

$$\left. \begin{aligned} Z_{11} &= 30\Omega \\ Z_{21} &= 20\Omega \\ Z_{12} &= 20\Omega \\ Z_{22} &= 50\Omega \end{aligned} \right\} \rightarrow Z = \begin{bmatrix} 30 & 20 \\ 20 & 50 \end{bmatrix}$$

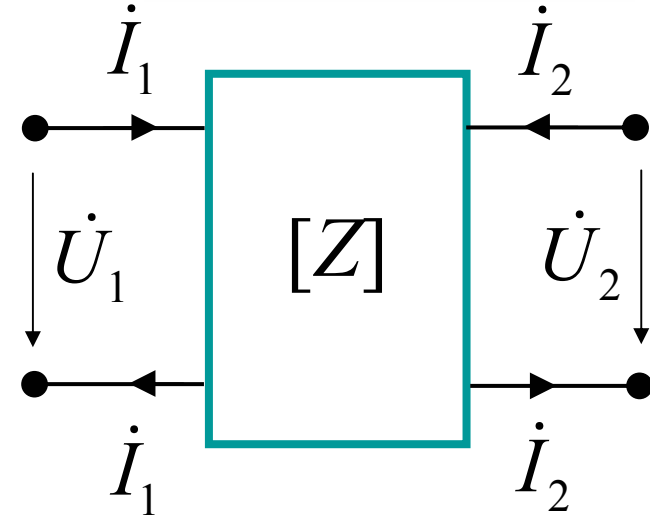

$$\begin{cases} \dot{U}_1 = Z_{11}\dot{I}_1 + Z_{12}\dot{I}_2 \\ \dot{U}_2 = Z_{21}\dot{I}_1 + Z_{22}\dot{I}_2 \end{cases}$$





**VD1**

**Z (11)**

$R_1 = 10 \Omega; R_2 = 20 \Omega; R_3 = 30 \Omega; \text{Tính bộ số } Z.$

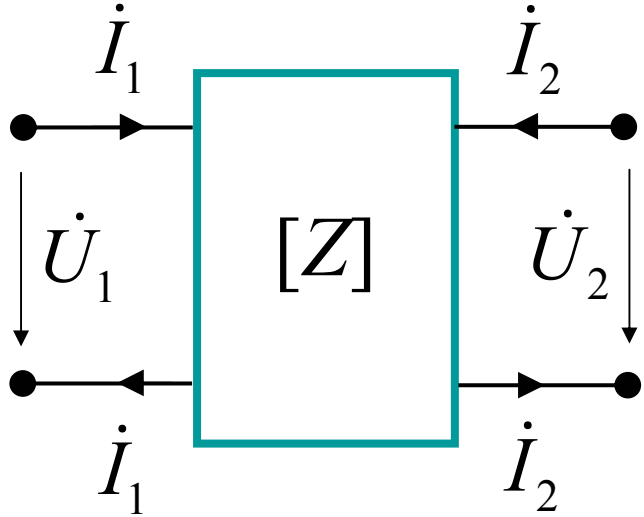
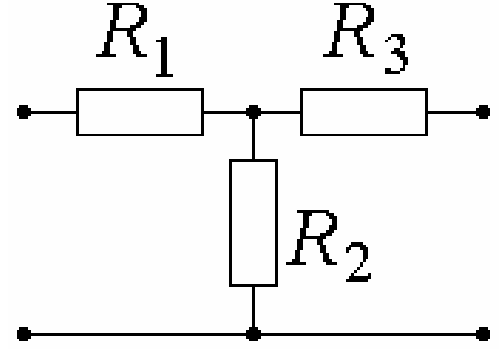

$$\rightarrow Z = \begin{bmatrix} 30 & 20 \\ 20 & 50 \end{bmatrix}$$

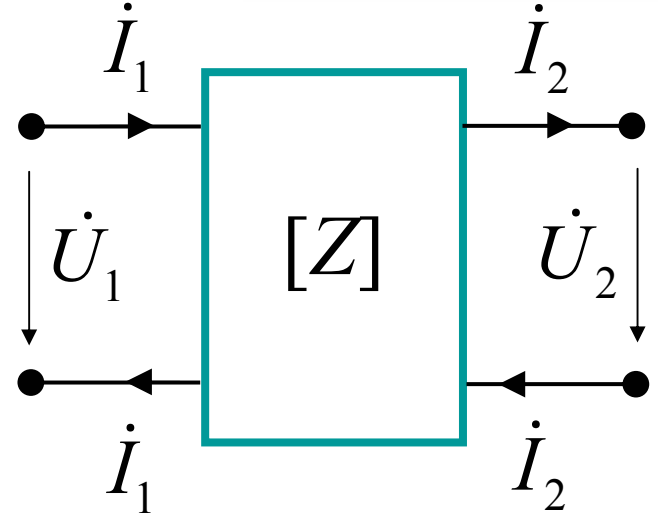

$$\rightarrow Z = ?$$



**VD1**

**Z (12)**

$R_1 = 10 \Omega; R_2 = 20 \Omega; R_3 = 30 \Omega; \text{Tính bộ số } Z.$

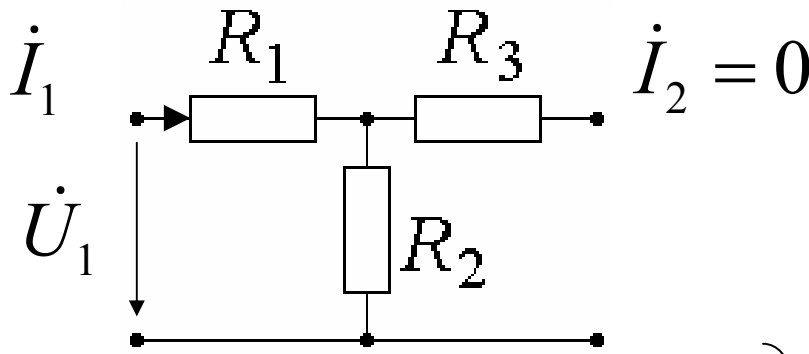

$$Z_{11} = \left. \frac{\dot{U}_1}{\dot{I}_1} \right|_{\dot{I}_2=0}$$

$$\dot{U}_1 = (R_1 + R_2)\dot{I}_1 = (10 + 20)\dot{I}_1 = 30\dot{I}_1$$

$$\rightarrow Z_{11} = \frac{\dot{U}_1}{\dot{I}_1} = \frac{30\dot{I}_1}{\dot{I}_1} = 30\Omega$$

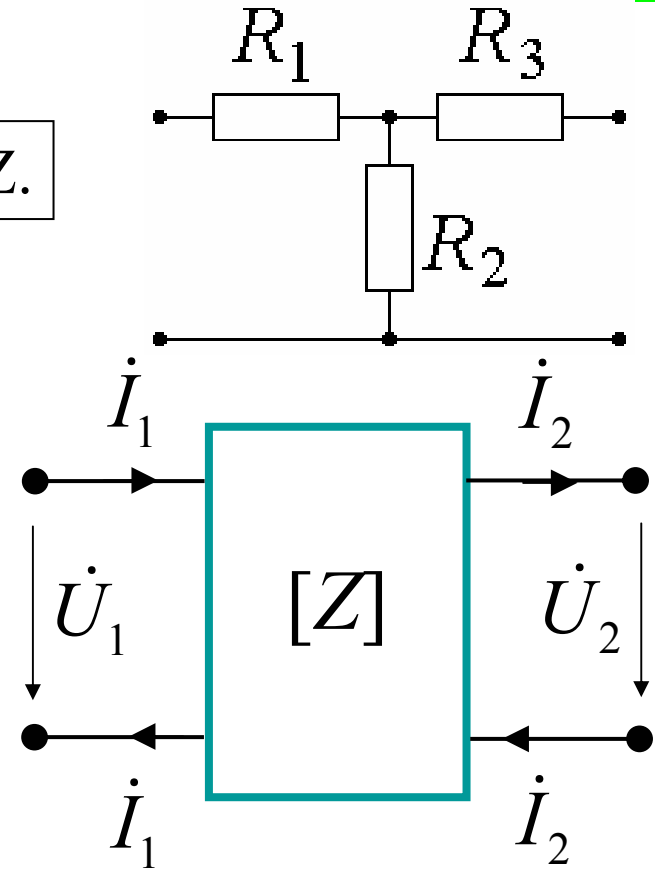

$$\begin{cases} \dot{U}_1 = Z_{11}\dot{I}_1 + Z_{12}\dot{I}_2 \\ \dot{U}_2 = Z_{21}\dot{I}_1 + Z_{22}\dot{I}_2 \end{cases}$$



**VD1**

**Z (13)**

$R_1 = 10 \Omega; R_2 = 20 \Omega; R_3 = 30 \Omega$ ; Tính bộ số Z.

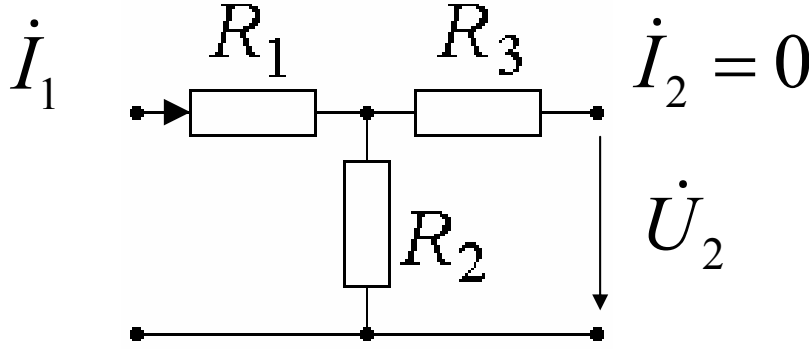

$$Z_{21} = \frac{\dot{U}_2}{\dot{I}_1} \Big|_{\dot{I}_2=0}$$

$$\dot{U}_2 = R_2 \dot{I}_1 = 20 \dot{I}_1$$

$$\rightarrow Z_{21} = \frac{\dot{U}_2}{\dot{I}_1} = \frac{20 \dot{I}_1}{\dot{I}_1} = 20 \Omega$$

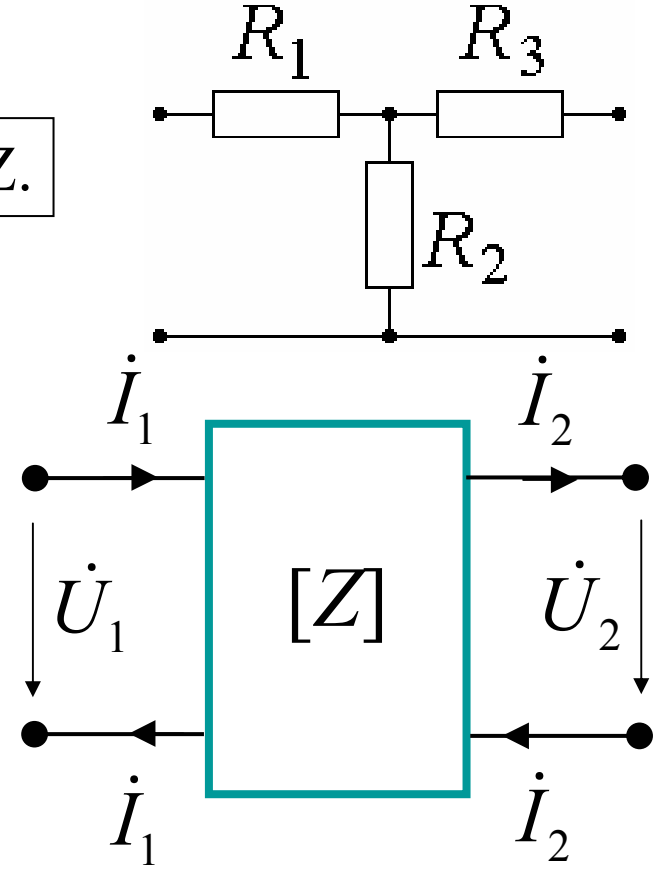

$$\begin{cases} \dot{U}_1 = Z_{11} \dot{I}_1 + Z_{12} \dot{I}_2 \\ \dot{U}_2 = Z_{21} \dot{I}_1 + Z_{22} \dot{I}_2 \end{cases}$$



**VD1**

**Z (14)**

$R_1 = 10 \Omega; R_2 = 20 \Omega; R_3 = 30 \Omega; \text{Tính bộ số } Z.$

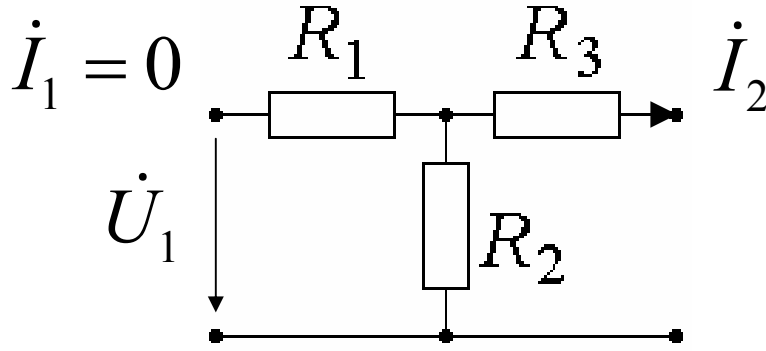

$$Z_{12} = \left. \frac{\dot{U}_1}{\dot{I}_2} \right|_{\dot{I}_1=0}$$

$$\dot{U}_1 = -R_2 \dot{I}_2 = -20 \dot{I}_1$$

$$\rightarrow Z_{12} = \frac{\dot{U}_1}{\dot{I}_2} = \frac{-20 \dot{I}_2}{\dot{I}_2} = -20 \Omega$$

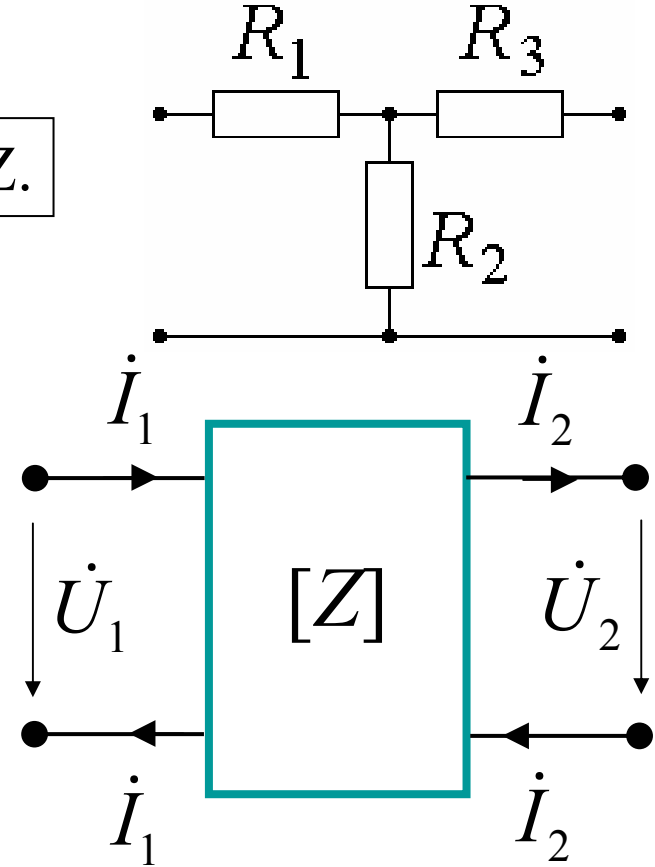

$$\begin{cases} \dot{U}_1 = Z_{11} \dot{I}_1 + Z_{12} \dot{I}_2 \\ \dot{U}_2 = Z_{21} \dot{I}_1 + Z_{22} \dot{I}_2 \end{cases}$$



**VD1**

**Z (15)**

$R_1 = 10 \Omega; R_2 = 20 \Omega; R_3 = 30 \Omega; \text{Tính bộ số } Z.$

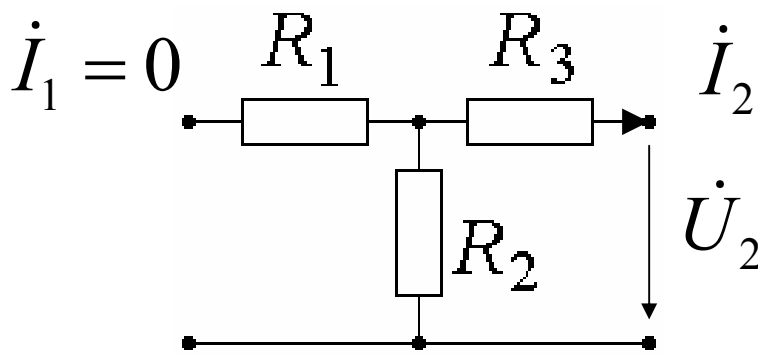

$$Z_{22} = \left. \frac{\dot{U}_2}{\dot{I}_2} \right|_{\dot{I}_1=0}$$

$$\dot{U}_2 = -(R_2 + R_3)\dot{I}_2 = -(20 + 30)\dot{I}_2 = -50\dot{I}_2$$

$$\rightarrow Z_{22} = \frac{\dot{U}_2}{\dot{I}_2} = \frac{-50\dot{I}_2}{\dot{I}_2} = -50\Omega$$

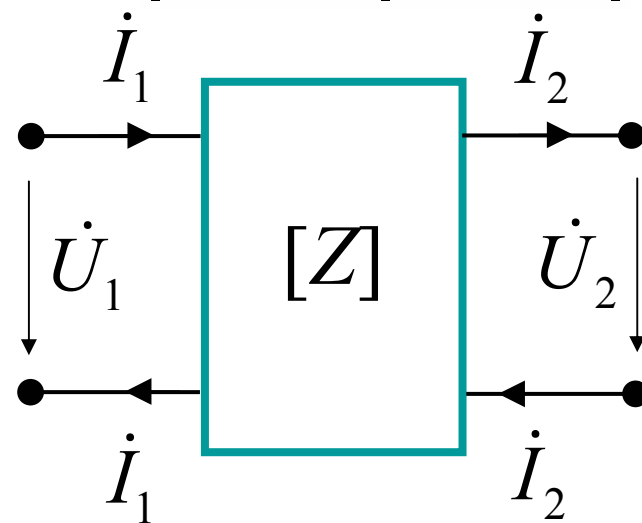
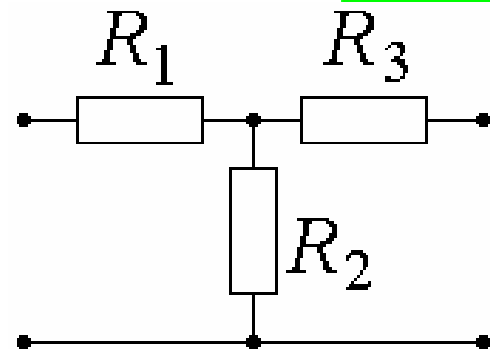

$$\begin{cases} \dot{U}_1 = Z_{11}\dot{I}_1 + Z_{12}\dot{I}_2 \\ \dot{U}_2 = Z_{21}\dot{I}_1 + Z_{22}\dot{I}_2 \end{cases}$$



**VD1**

**Z (16)**

$R_1 = 10 \Omega; R_2 = 20 \Omega; R_3 = 30 \Omega; \text{Tính bộ số } Z.$

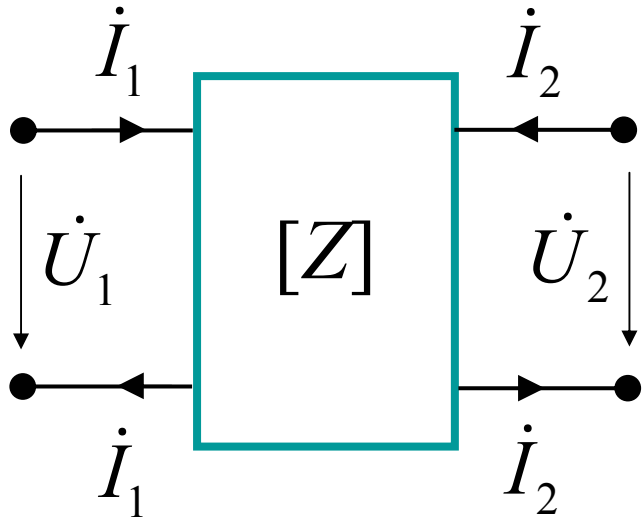
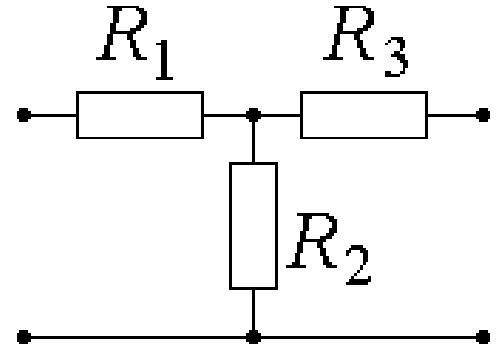

$$\rightarrow Z = \begin{bmatrix} 30 & 20 \\ 20 & 50 \end{bmatrix}$$

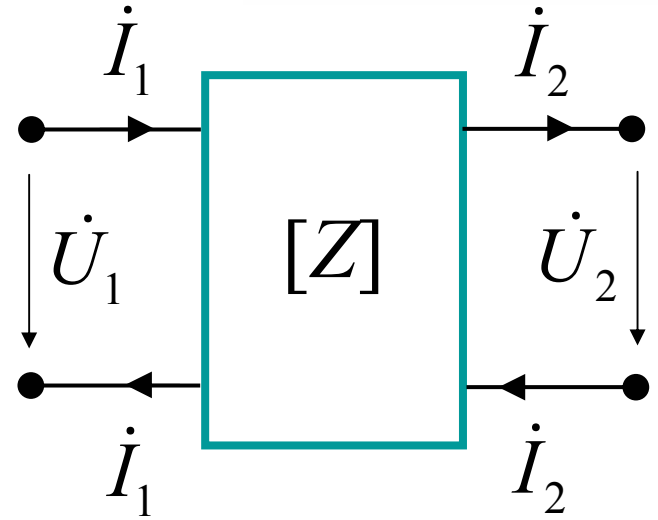

$$\rightarrow Z = \begin{bmatrix} 30 & -20 \\ 20 & -50 \end{bmatrix}$$



## Mạng hai cửa

- Z
- **Y**
- H
- G
- A
- B



# Y (1)

- Có một số mạng hai cửa không có bộ số  $Z$
- $\rightarrow$  mô tả bằng bộ số  $Y$
- Còn gọi là bộ số tổng dẫn

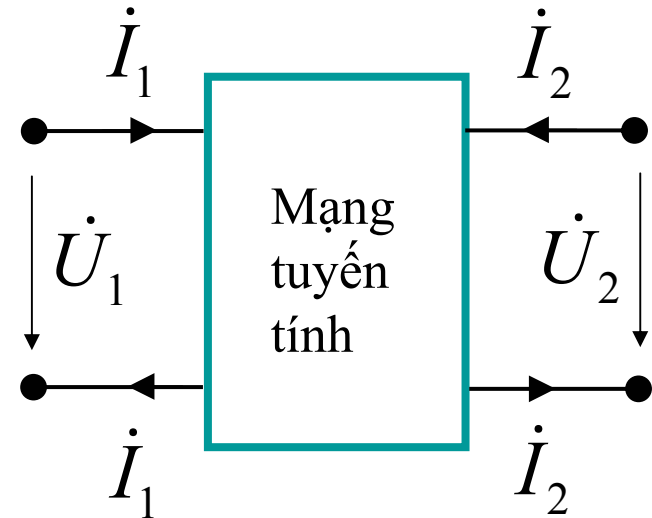

$$\begin{cases} \dot{I}_1 = Y_{11}\dot{U}_1 + Y_{12}\dot{U}_2 \\ \dot{I}_2 = Y_{21}\dot{U}_1 + Y_{22}\dot{U}_2 \end{cases} \Leftrightarrow \begin{bmatrix} \dot{I}_1 \\ \dot{I}_2 \end{bmatrix} = \begin{bmatrix} Y_{11} & Y_{12} \\ Y_{21} & Y_{22} \end{bmatrix} \begin{bmatrix} \dot{U}_1 \\ \dot{U}_2 \end{bmatrix} = [Y] \begin{bmatrix} \dot{U}_1 \\ \dot{U}_2 \end{bmatrix}$$



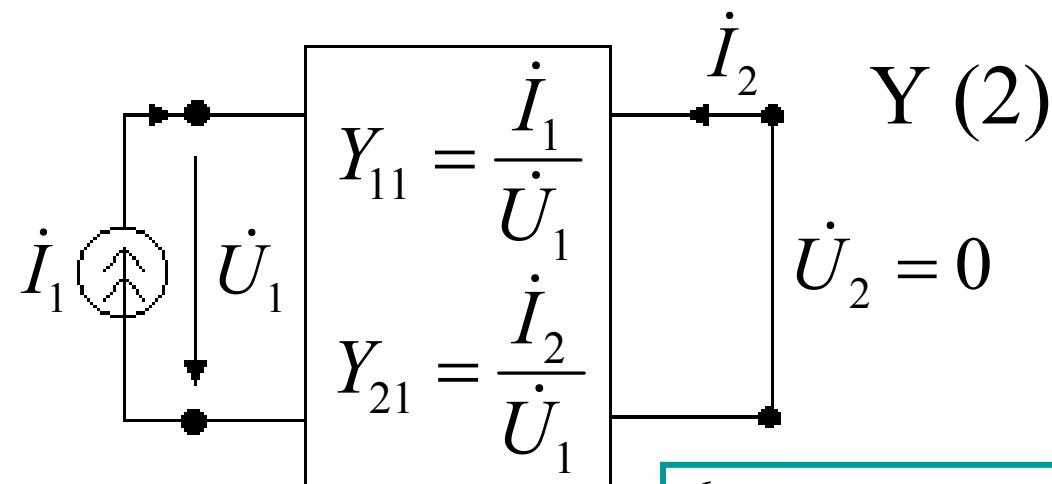
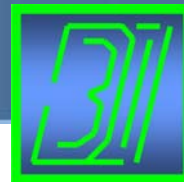

$$\begin{cases} \dot{I}_1 = Y_{11}\dot{U}_1 + Y_{12}\dot{U}_2 \\ \dot{I}_2 = Y_{21}\dot{U}_1 + Y_{22}\dot{U}_2 \end{cases}$$

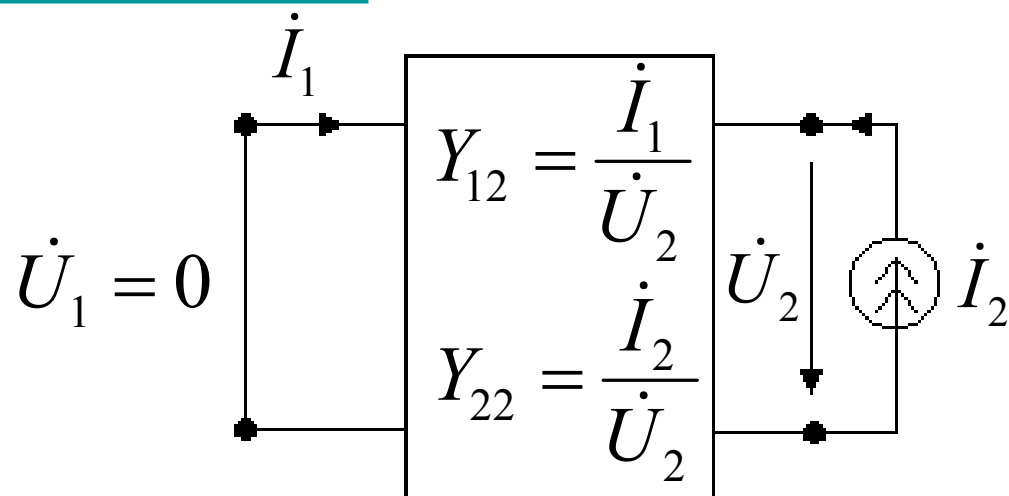

Mạng hai cửa



VD

Y (3)

$R_1 = 1 \Omega; R_2 = 2 \Omega; R_3 = 3 \Omega$ ; Tính bộ số Y.

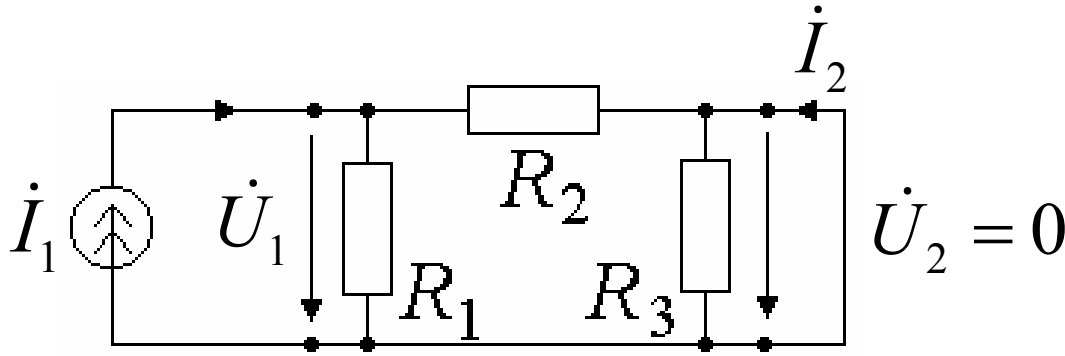

$$Y_{11} = \left. \frac{\dot{I}_1}{\dot{U}_1} \right|_{\dot{U}_2=0}$$

$$\dot{U}_1 = (R_1 // R_2) \dot{I}_1 = \frac{1 \cdot 2}{1 + 2} \dot{I}_1 = 0,67 \dot{I}_1$$

$$\rightarrow Y_{11} = \frac{\dot{I}_1}{0,67 \dot{I}_1} = 1,5 \text{ S}$$

Mạng hai cửa

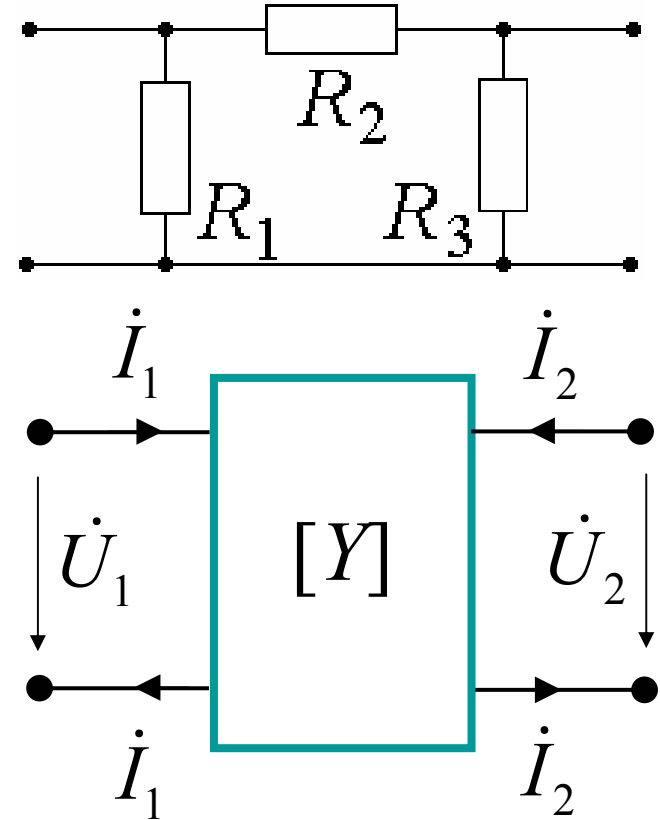

$$\begin{cases} \dot{I}_1 = Y_{11} \dot{U}_1 + Y_{12} \dot{U}_2 \\ \dot{I}_2 = Y_{21} \dot{U}_1 + Y_{22} \dot{U}_2 \end{cases}$$



VD

Y (4)

$R_1 = 1 \Omega; R_2 = 2 \Omega; R_3 = 3 \Omega; \text{Tính bộ số } Y.$

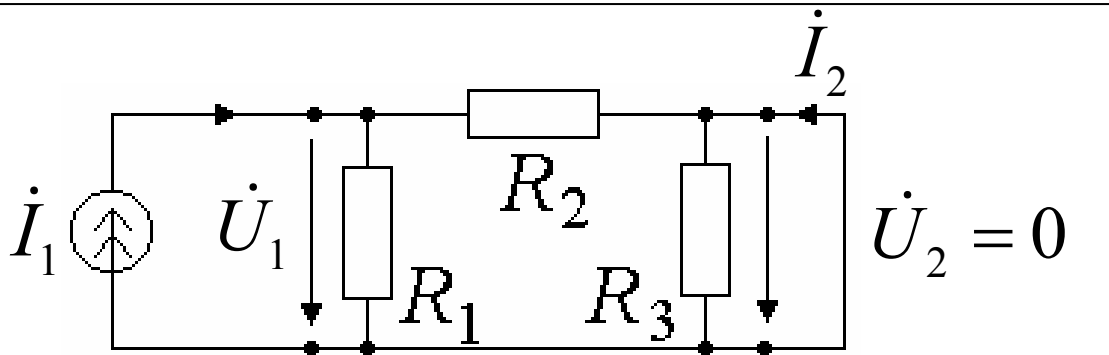

$$Y_{21} = \left. \frac{\dot{I}_2}{\dot{U}_1} \right|_{\dot{U}_2=0}$$

$$\dot{U}_1 = \dot{U}_{R1} = \dot{U}_{R2} = -R_2 \dot{I}_2 = -2 \dot{I}_2$$

$$\rightarrow Y_{21} = \frac{\dot{I}_2}{-2 \dot{I}_2} = -0,5 \text{ S}$$

Mạng hai cửa

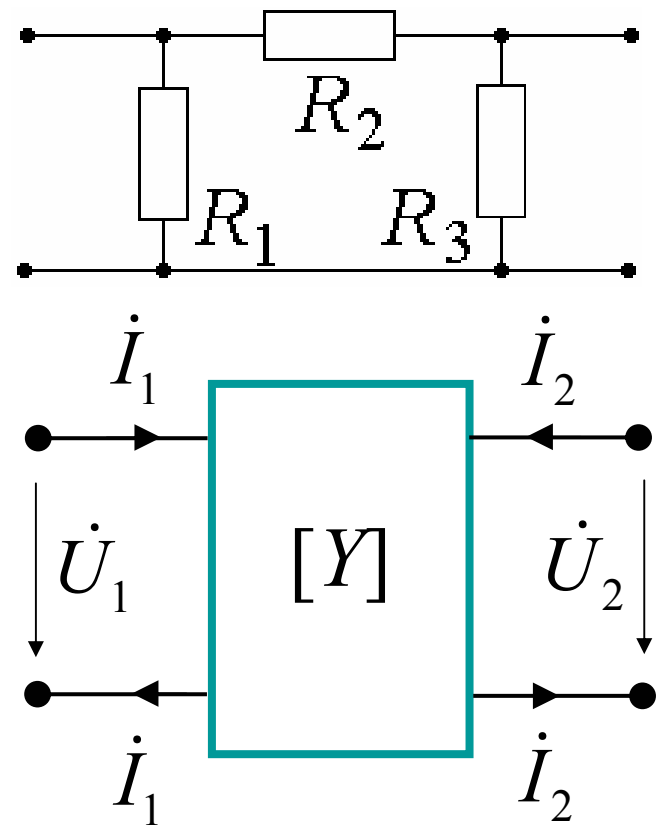

$$\begin{cases} \dot{I}_1 = Y_{11} \dot{U}_1 + Y_{12} \dot{U}_2 \\ \dot{I}_2 = Y_{21} \dot{U}_1 + Y_{22} \dot{U}_2 \end{cases}$$



VD

Y (5)

$R_1 = 1 \Omega; R_2 = 2 \Omega; R_3 = 3 \Omega$ ; Tính bộ số Y.

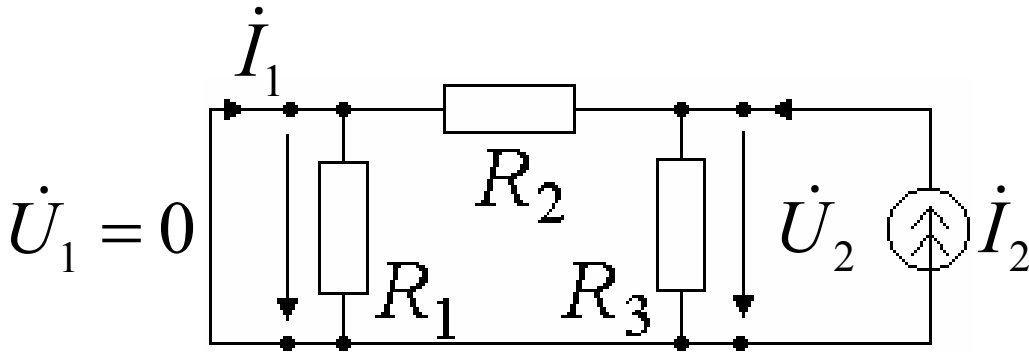

$$Y_{22} = \frac{I_2}{U_2} \Big|_{U_1=0}$$

$$U_2 = (R_2 // R_3) I_2 = \frac{2 \cdot 3}{2 + 3} I_2 = 1,2 I_2$$

$$\rightarrow Y_{22} = \frac{I_2}{1,2 I_2} = 0,83 \text{ S}$$

Mạng hai cửa

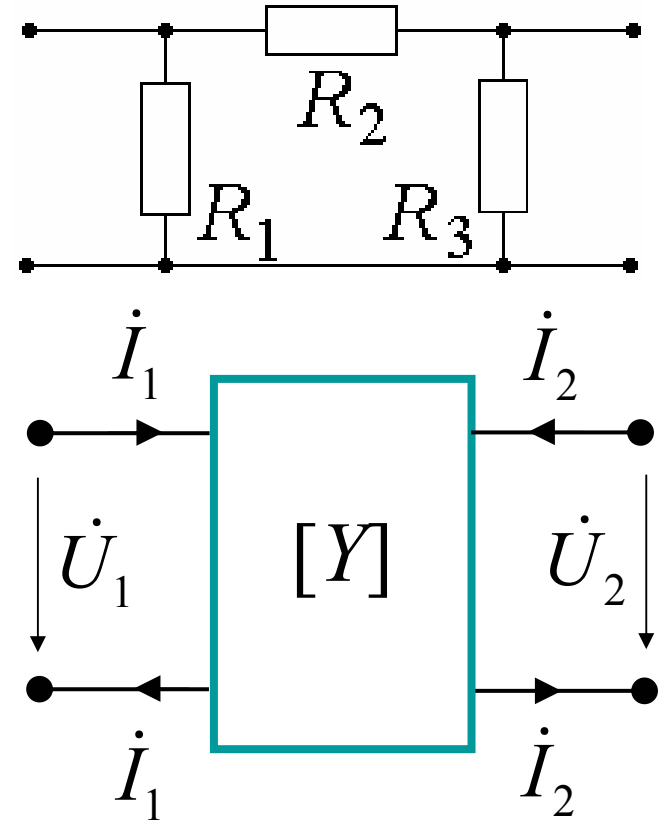

$$\begin{cases} I_1 = Y_{11} U_1 + Y_{12} U_2 \\ I_2 = Y_{21} U_1 + Y_{22} U_2 \end{cases}$$



VD

Y (6)

$R_1 = 1 \Omega; R_2 = 2 \Omega; R_3 = 3 \Omega; \text{Tính bộ số } Y.$

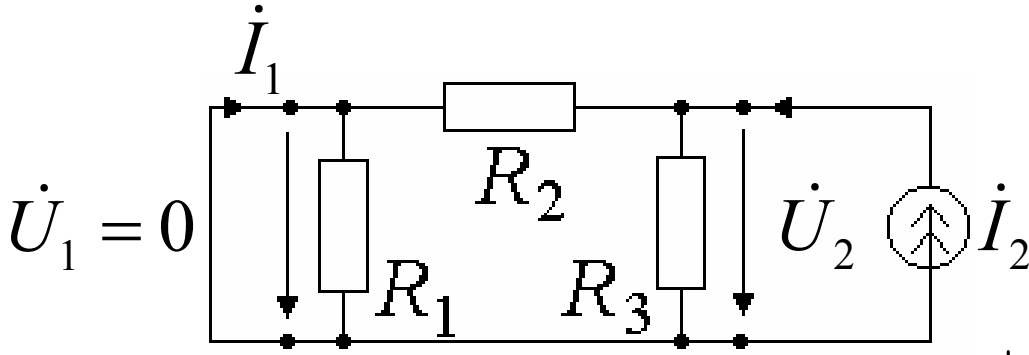

$$Y_{12} = \left. \frac{\dot{I}_1}{\dot{U}_2} \right|_{\dot{U}_1=0}$$

$$\dot{U}_2 = \dot{U}_{R3} = \dot{U}_{R2} = -R_2 \dot{I}_1 = -2\dot{I}_1$$

$$\rightarrow Y_{12} = \frac{\dot{I}_1}{-2\dot{I}_1} = -0,5 \text{ S}$$

Mạng hai cửa

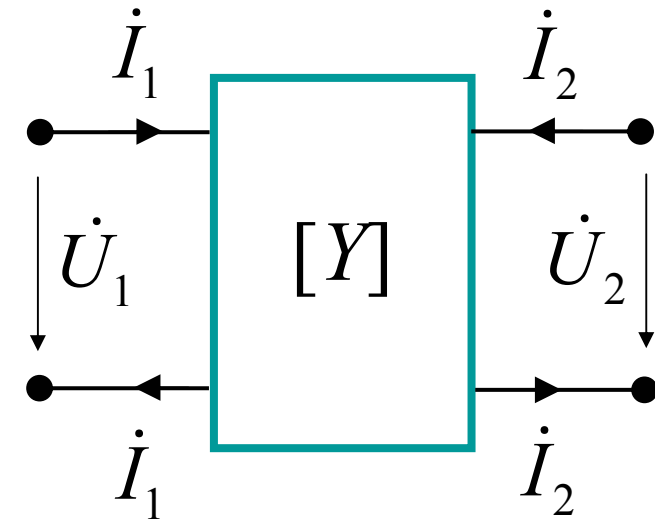
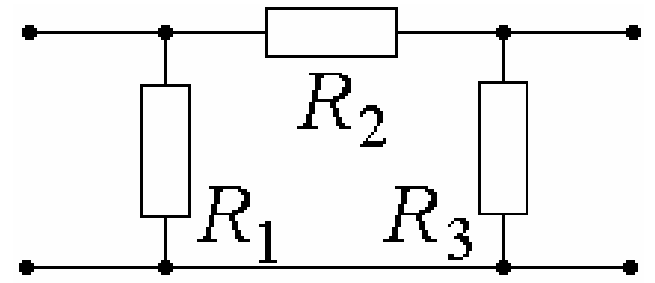

$$\begin{cases} \dot{I}_1 = Y_{11}\dot{U}_1 + Y_{12}\dot{U}_2 \\ \dot{I}_2 = Y_{21}\dot{U}_1 + Y_{22}\dot{U}_2 \end{cases}$$



**VD**

**Y (7)**

$R_1 = 1 \Omega; R_2 = 2 \Omega; R_3 = 3 \Omega; \text{Tính bộ số } Y.$

$$Y_{11} = 1,5 S$$

$$Y_{21} = -0,5 S$$

$$Y_{12} = -0,5 S$$

$$Y_{22} = 0,83 S$$

$$\rightarrow Y = \begin{bmatrix} 1,5 & -0,5 \\ -0,5 & 0,83 \end{bmatrix}$$

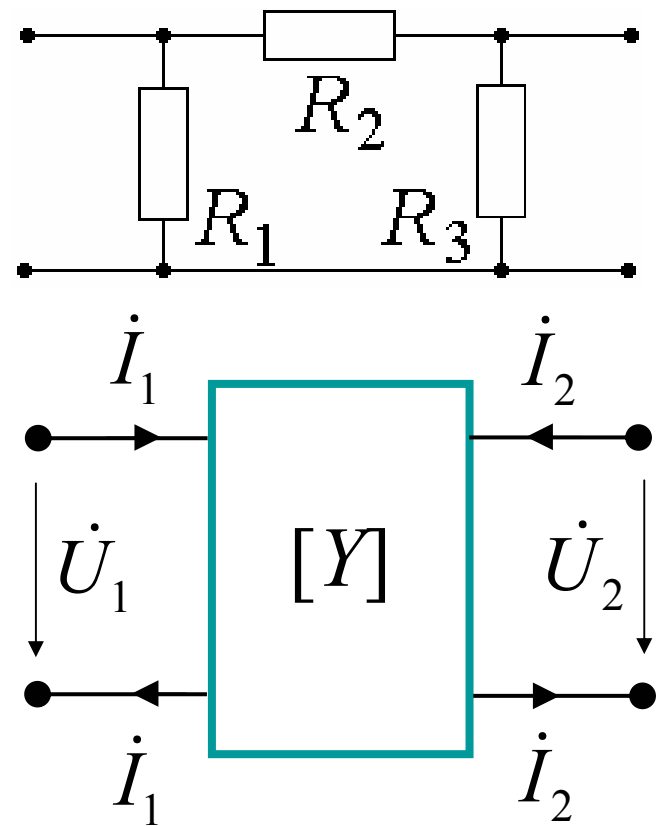

$$\begin{cases} \dot{I}_1 = Y_{11}\dot{U}_1 + Y_{12}\dot{U}_2 \\ \dot{I}_2 = Y_{21}\dot{U}_1 + Y_{22}\dot{U}_2 \end{cases}$$



## Mạng hai cửa

- Z
- Y
- **H**
- G
- A
- B



# H (1)

- Còn gọi là bộ số lai (H: hybrid)
- Dùng để mô tả các linh kiện điện tử (ví dụ transistor)

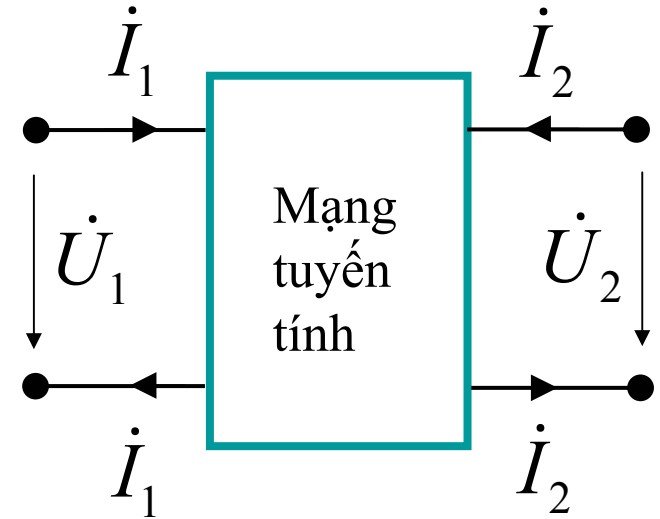

$$\begin{cases} \dot{U}_1 = H_{11}\dot{I}_1 + H_{12}\dot{U}_2 \\ \dot{I}_2 = H_{21}\dot{I}_1 + H_{22}\dot{U}_2 \end{cases} \Leftrightarrow \begin{bmatrix} \dot{U}_1 \\ \dot{I}_2 \end{bmatrix} = \begin{bmatrix} H_{11} & H_{12} \\ H_{21} & H_{22} \end{bmatrix} \begin{bmatrix} \dot{I}_1 \\ \dot{U}_2 \end{bmatrix} = [H] \begin{bmatrix} \dot{I}_1 \\ \dot{U}_2 \end{bmatrix}$$



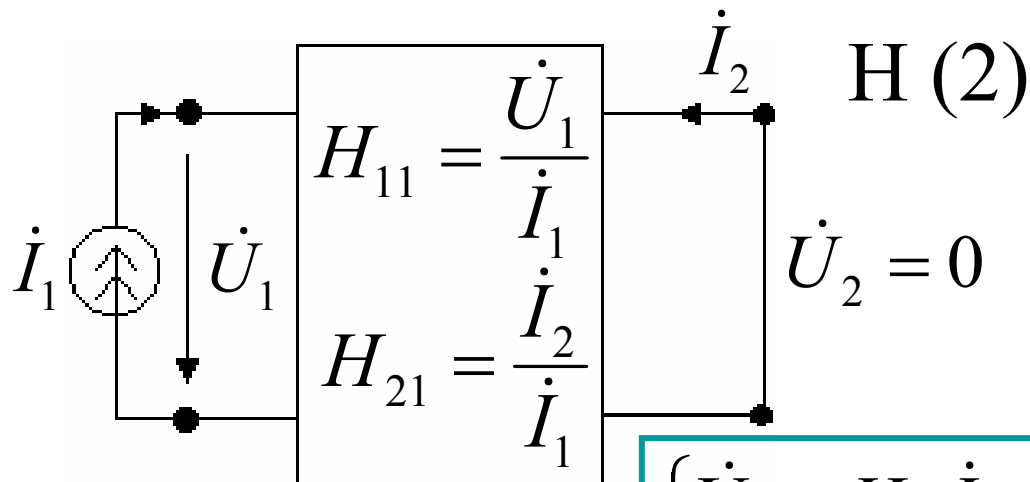

$$\begin{cases} \dot{U}_1 = H_{11}\dot{I}_1 + H_{12}\dot{U}_2 \\ \dot{I}_2 = H_{21}\dot{I}_1 + H_{22}\dot{U}_2 \end{cases}$$

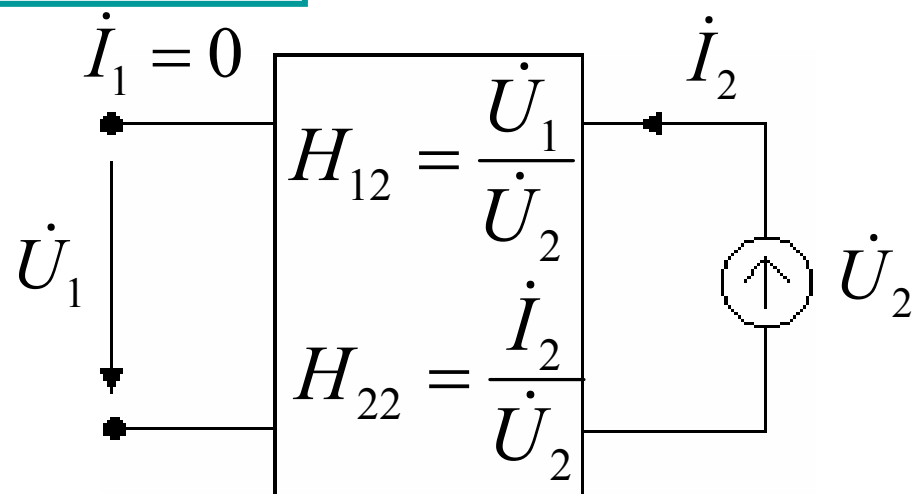



## Mạng hai cửa

- Z
- Y
- H
- **G**
- A
- B



# G (1)

- Còn gọi là bộ số lai nghịch đảo

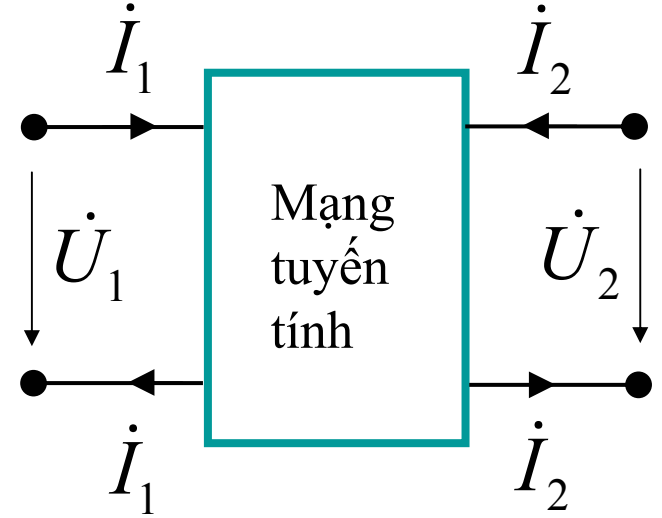

$$\begin{cases} \dot{I}_1 = G_{11}\dot{U}_1 + G_{12}\dot{I}_2 \\ \dot{U}_2 = G_{21}\dot{U}_1 + G_{22}\dot{I}_2 \end{cases} \Leftrightarrow \begin{bmatrix} \dot{I}_1 \\ \dot{U}_2 \end{bmatrix} = \begin{bmatrix} G_{11} & G_{12} \\ G_{21} & G_{22} \end{bmatrix} \begin{bmatrix} \dot{U}_1 \\ \dot{I}_2 \end{bmatrix} = [G] \begin{bmatrix} \dot{U}_1 \\ \dot{I}_2 \end{bmatrix}$$

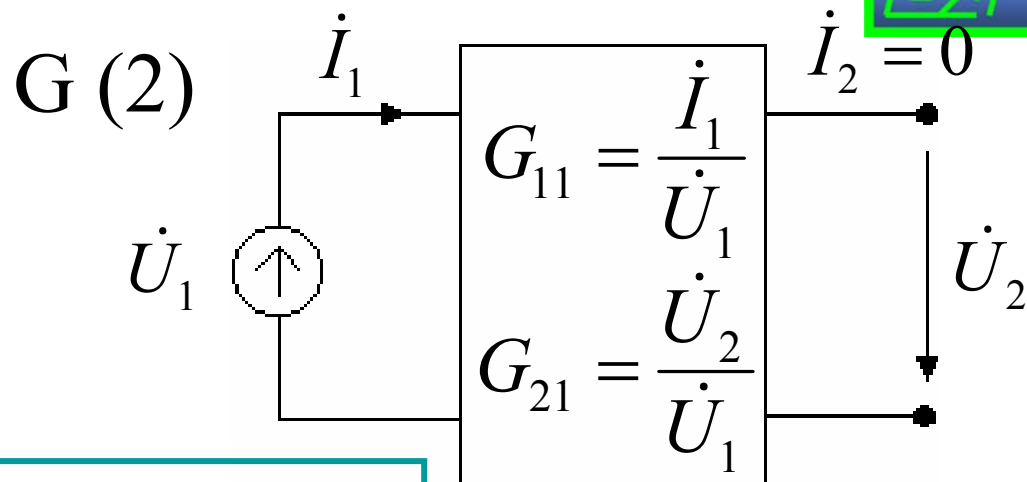

$$\begin{cases} \dot{I}_1 = G_{11}\dot{U}_1 + G_{12}\dot{I}_2 \\ \dot{U}_2 = G_{21}\dot{U}_1 + G_{22}\dot{I}_2 \end{cases}$$

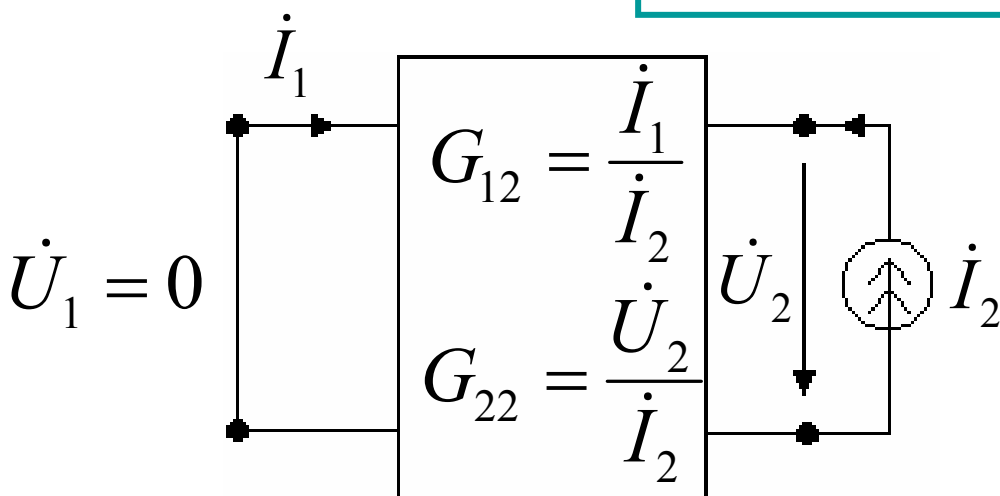

Mạng hai cửa



## Mạng hai cửa

- Z
- Y
- H
- G
- **A**
- B



# A (1)

- Còn gọi là bộ số truyền tải
- Ký hiệu khác: T
- Thường được dùng trong phân tích đường dây truyền tải (hệ thống điện, hệ thống liên lạc)

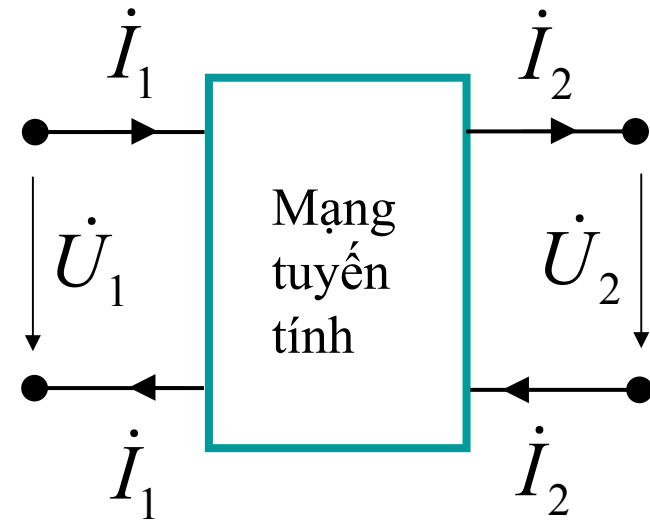

$$\begin{cases} \dot{U}_1 = A_{11}\dot{U}_2 + A_{12}\dot{I}_2 \\ \dot{I}_1 = A_{21}\dot{U}_2 + A_{22}\dot{I}_2 \end{cases} \Leftrightarrow \begin{bmatrix} \dot{U}_1 \\ \dot{I}_1 \end{bmatrix} = \begin{bmatrix} A_{11} & A_{12} \\ A_{21} & A_{22} \end{bmatrix} \begin{bmatrix} \dot{U}_2 \\ \dot{I}_2 \end{bmatrix} = [A] \begin{bmatrix} \dot{U}_2 \\ \dot{I}_2 \end{bmatrix}$$

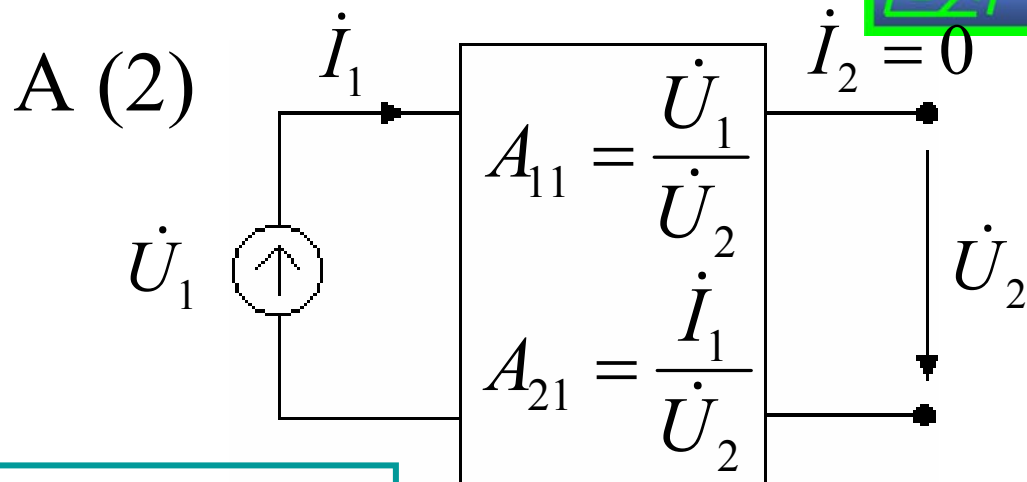

$$\begin{cases} \dot{U}_1 = A_{11}\dot{U}_2 + A_{12}\dot{I}_2 \\ \dot{I}_1 = A_{21}\dot{U}_2 + A_{22}\dot{I}_2 \end{cases}$$

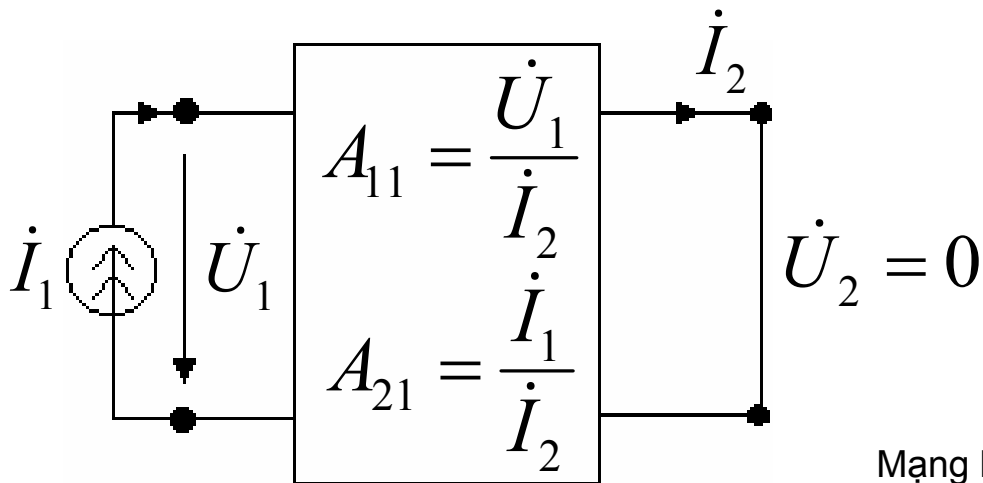

Mạng hai cửa



## Mạng hai cửa

- Z
- Y
- H
- G
- A
- **B**





## B (1)

- Còn gọi là bộ số truyền tải ngược
- Ký hiệu khác:  $t$

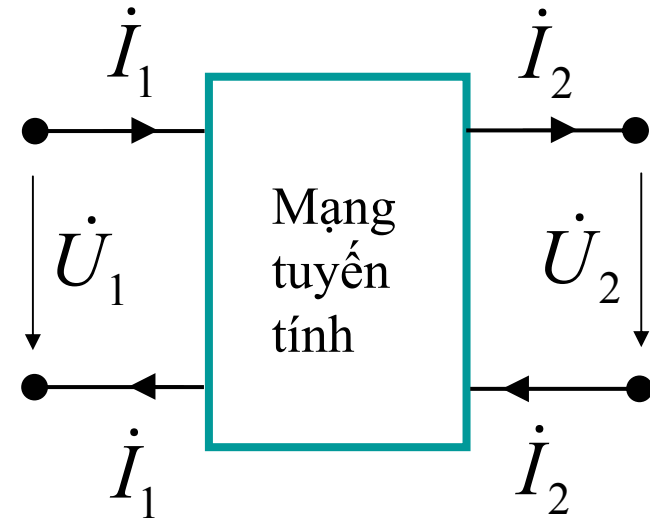

$$\begin{cases} \dot{U}_2 = B_{11}\dot{U}_1 + B_{12}\dot{I}_1 \\ \dot{I}_2 = B_{21}\dot{U}_1 + B_{22}\dot{I}_1 \end{cases} \Leftrightarrow \begin{bmatrix} \dot{U}_2 \\ \dot{I}_2 \end{bmatrix} = \begin{bmatrix} B_{11} & B_{12} \\ B_{21} & B_{22} \end{bmatrix} \begin{bmatrix} \dot{U}_1 \\ \dot{I}_1 \end{bmatrix} = [B] \begin{bmatrix} \dot{U}_1 \\ \dot{I}_1 \end{bmatrix}$$

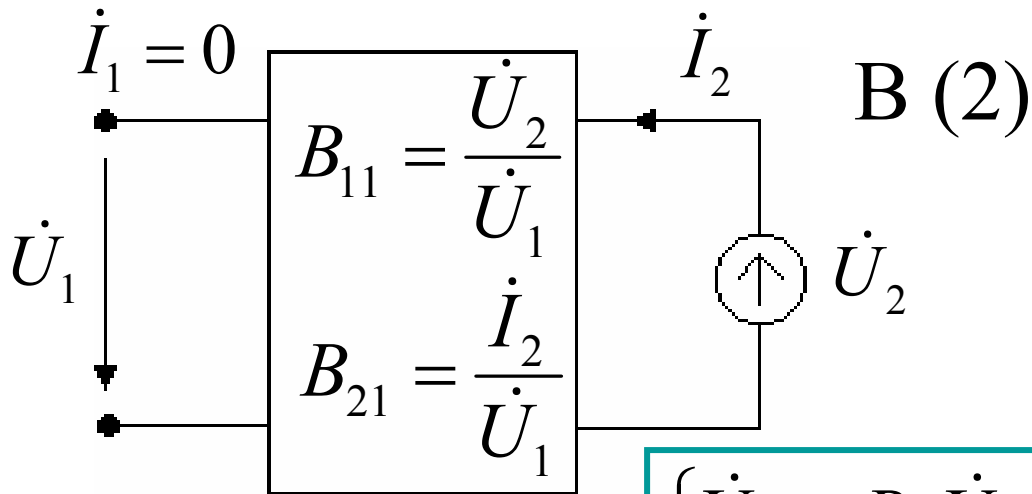

$$\begin{cases} \dot{U}_2 = B_{11}\dot{U}_1 + B_{12}\dot{I}_1 \\ \dot{I}_2 = B_{21}\dot{U}_1 + B_{22}\dot{I}_1 \end{cases}$$

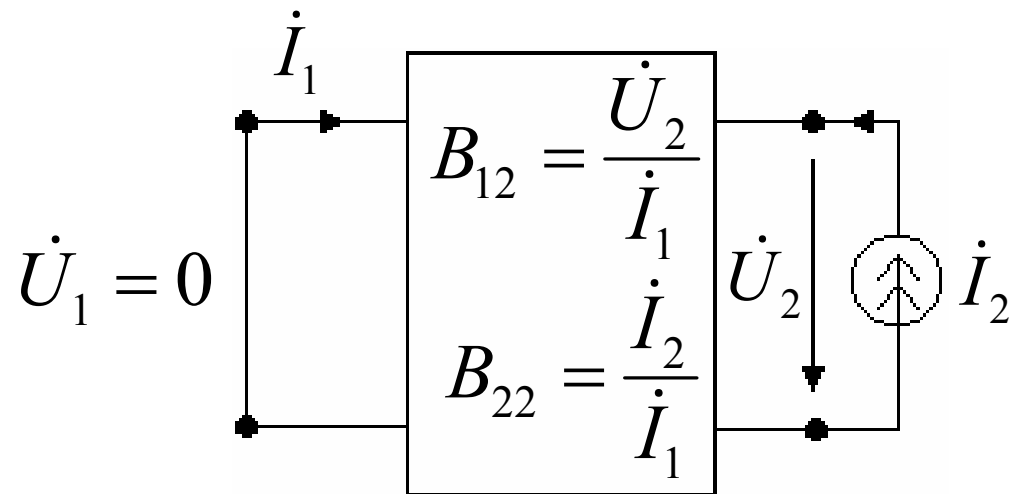

Mạng hai cửa

## Mạng hai cửa

$$\begin{cases} \dot{U}_1 = Z_{11}\dot{I}_1 + Z_{12}\dot{I}_2 \\ \dot{U}_2 = Z_{21}\dot{I}_1 + Z_{22}\dot{I}_2 \end{cases}$$

$$\begin{cases} \dot{U}_1 = H_{11}\dot{I}_1 + H_{12}\dot{U}_2 \\ \dot{I}_2 = H_{21}\dot{I}_1 + H_{22}\dot{U}_2 \end{cases}$$

$$\begin{cases} \dot{U}_1 = A_{11}\dot{U}_2 + A_{12}\dot{I}_2 \\ \dot{I}_1 = A_{21}\dot{U}_2 + A_{22}\dot{I}_2 \end{cases}$$

$$\begin{cases} \dot{I}_1 = Y_{11}\dot{U}_1 + Y_{12}\dot{U}_2 \\ \dot{I}_2 = Y_{21}\dot{U}_1 + Y_{22}\dot{U}_2 \end{cases}$$

$$\begin{cases} \dot{I}_1 = G_{11}\dot{U}_1 + G_{12}\dot{I}_2 \\ \dot{U}_2 = G_{21}\dot{U}_1 + G_{22}\dot{I}_2 \end{cases}$$

$$\begin{cases} \dot{U}_2 = B_{11}\dot{U}_1 + B_{12}\dot{I}_1 \\ \dot{I}_2 = B_{21}\dot{U}_1 + B_{22}\dot{I}_1 \end{cases}$$

## Mạng hai cửa

- Các bộ thông số
- **Quan hệ giữa các bộ thông số**
- Phân tích mạch có mạng hai cửa
- Kết nối các mạng hai cửa
- Mạng  $T$  &  $\Pi$
- Tương hỗ
- Tổng trở vào & hoà hợp tải
- Hàm truyền đạt

## Quan hệ giữa các bộ thông số (1)

$$\begin{bmatrix} \dot{U}_1 \\ \dot{U}_2 \end{bmatrix} = \begin{bmatrix} Z_{11} & Z_{12} \\ Z_{21} & Z_{22} \end{bmatrix} \begin{bmatrix} \dot{I}_1 \\ \dot{I}_2 \end{bmatrix} = [Z] \begin{bmatrix} \dot{I}_1 \\ \dot{I}_2 \end{bmatrix}$$

$$\rightarrow \begin{bmatrix} \dot{I}_1 \\ \dot{I}_2 \end{bmatrix} = [Z]^{-1} \begin{bmatrix} \dot{U}_1 \\ \dot{U}_2 \end{bmatrix}$$

$$\begin{bmatrix} \dot{I}_1 \\ \dot{I}_2 \end{bmatrix} = \begin{bmatrix} Y_{11} & Y_{12} \\ Y_{21} & Y_{22} \end{bmatrix} \begin{bmatrix} \dot{U}_1 \\ \dot{U}_2 \end{bmatrix} = [Y] \begin{bmatrix} \dot{U}_1 \\ \dot{U}_2 \end{bmatrix}$$

$$\rightarrow [Y] = [Z]^{-1}$$

## Quan hệ giữa các bộ thông số (2)

$$[Y] = [Z]^{-1}$$

$$[G] = [H]^{-1}$$

$$[B] = [A]^{-1}$$



	<b>Z</b>		<b>Y</b>		<b>H</b>		<b>G</b>		<b>A</b>		<b>B</b>	
<b>Z</b>	$Z_{11}$	$Z_{12}$	$\frac{Y_{22}}{\Delta_Y}$	$-\frac{Y_{12}}{\Delta_Y}$	$\frac{\Delta_H}{H_{22}}$	$\frac{H_{12}}{H_{22}}$	$\frac{1}{G_{11}}$	$-\frac{G_{12}}{G_{11}}$	$\frac{A_{11}}{A_{21}}$	$-\frac{\Delta_A}{A_{21}}$	$-\frac{B_{22}}{B_{21}}$	$\frac{1}{B_{21}}$
	$Z_{21}$	$Z_{22}$	$-\frac{Y_{21}}{\Delta_Y}$	$\frac{Y_{11}}{\Delta_Y}$	$-\frac{H_{22}}{H_{21}}$	$\frac{1}{H_{22}}$	$\frac{G_{21}}{G_{11}}$	$\frac{\Delta_G}{G_{11}}$	$\frac{1}{A_{21}}$	$-\frac{A_{22}}{A_{21}}$	$-\frac{\Delta_B}{B_{21}}$	$\frac{B_{11}}{B_{21}}$
<b>Y</b>	$\frac{Z_{22}}{\Delta_Z}$	$-\frac{Z_{12}}{\Delta_Z}$	$Y_{11}$	$Y_{12}$	$\frac{1}{H_{11}}$	$-\frac{H_{12}}{H_{11}}$	$\frac{\Delta_G}{G_{22}}$	$\frac{G_{12}}{G_{22}}$	$\frac{A_{22}}{A_{12}}$	$-\frac{\Delta_A}{A_{12}}$	$-\frac{B_{11}}{B_{12}}$	$\frac{1}{B_{12}}$
	$-\frac{Z_{21}}{\Delta_Z}$	$\frac{Z_{11}}{\Delta_Z}$	$Y_{21}$	$Y_{22}$	$\frac{H_{21}}{H_{11}}$	$\frac{\Delta_H}{H_{11}}$	$-\frac{G_{21}}{G_{22}}$	$\frac{1}{G_{22}}$	$\frac{1}{A_{12}}$	$-\frac{A_{11}}{A_{12}}$	$-\frac{\Delta_B}{B_{12}}$	$\frac{B_{22}}{B_{12}}$
<b>H</b>	$\frac{\Delta_Z}{Z_{22}}$	$\frac{Z_{12}}{Z_{22}}$	$\frac{1}{Y_{11}}$	$-\frac{Y_{12}}{Y_{11}}$	$H_{11}$	$H_{12}$	$\frac{G_{22}}{\Delta_G}$	$-\frac{G_{12}}{\Delta_G}$	$\frac{A_{12}}{A_{22}}$	$\frac{\Delta_A}{A_{22}}$	$-\frac{B_{12}}{B_{11}}$	$\frac{1}{B_{11}}$
	$-\frac{Z_{21}}{Z_{22}}$	$\frac{1}{Z_{22}}$	$\frac{Y_{21}}{Y_{11}}$	$\frac{\Delta_Y}{Y_{11}}$	$H_{21}$	$H_{22}$	$-\frac{G_{21}}{\Delta_G}$	$\frac{G_{11}}{\Delta_G}$	$\frac{1}{A_{22}}$	$-\frac{A_{21}}{A_{22}}$	$-\frac{\Delta_B}{B_{11}}$	$\frac{B_{21}}{B_{11}}$
<b>G</b>	$\frac{1}{Z_{11}}$	$-\frac{Z_{12}}{Z_{11}}$	$\frac{\Delta_Y}{Y_{22}}$	$\frac{Y_{12}}{Y_{22}}$	$\frac{H_{22}}{\Delta_H}$	$-\frac{H_{12}}{\Delta_H}$	$G_{11}$	$G_{12}$	$\frac{A_{21}}{A_{11}}$	$\frac{\Delta_A}{A_{11}}$	$-\frac{B_{21}}{B_{22}}$	$\frac{1}{B_{22}}$
	$\frac{Z_{21}}{Z_{11}}$	$\frac{\Delta_Z}{Z_{11}}$	$-\frac{Y_{21}}{Y_{22}}$	$\frac{1}{Y_{22}}$	$-\frac{H_{21}}{\Delta_H}$	$\frac{H_{11}}{\Delta_H}$	$G_{21}$	$G_{22}$	$\frac{1}{A_{11}}$	$-\frac{A_{12}}{A_{11}}$	$\frac{\Delta_B}{B_{22}}$	$\frac{B_{12}}{B_{22}}$
<b>A</b>	$\frac{Z_{11}}{Z_{21}}$	$\frac{\Delta_Z}{Z_{21}}$	$-\frac{Y_{22}}{Y_{21}}$	$-\frac{1}{Y_{21}}$	$-\frac{\Delta_H}{H_{21}}$	$-\frac{H_{11}}{H_{21}}$	$\frac{1}{G_{21}}$	$\frac{G_{22}}{G_{21}}$	$A_{11}$	$A_{12}$	$\frac{B_{22}}{\Delta_B}$	$\frac{B_{12}}{\Delta_B}$
	$\frac{1}{Z_{21}}$	$\frac{Z_{22}}{Z_{21}}$	$-\frac{\Delta_Y}{Y_{21}}$	$-\frac{Y_{11}}{Y_{21}}$	$-\frac{H_{22}}{H_{21}}$	$-\frac{1}{H_{21}}$	$\frac{G_{11}}{G_{21}}$	$\frac{\Delta_G}{G_{21}}$	$A_{21}$	$A_{22}$	$\frac{B_{21}}{\Delta_B}$	$\frac{B_{11}}{\Delta_B}$
<b>B</b>	$\frac{Z_{22}}{Z_{12}}$	$\frac{\Delta_Z}{Z_{12}}$	$-\frac{Y_{11}}{Y_{12}}$	$-\frac{1}{Y_{12}}$	$\frac{1}{H_{12}}$	$\frac{H_{11}}{H_{12}}$	$-\frac{\Delta_G}{G_{12}}$	$-\frac{G_{22}}{G_{12}}$	$\frac{A_{22}}{\Delta_A}$	$\frac{A_{12}}{\Delta_A}$	$B_{11}$	$B_{12}$
	$\frac{1}{Z_{12}}$	$\frac{Z_{11}}{Z_{12}}$	$-\frac{\Delta_Y}{Y_{12}}$	$-\frac{Y_{22}}{Y_{12}}$	$\frac{H_{22}}{H_{12}}$	$\frac{\Delta_H}{H_{12}}$	$-\frac{G_{11}}{G_{12}}$	$-\frac{1}{G_{12}}$	$-\frac{A_{21}}{\Delta_A}$	$-\frac{A_{11}}{\Delta_A}$	$B_{21}$	$B_{22}$

$$\Delta_Z = Z_{11}Z_{22} - Z_{12}Z_{21}$$

$$\Delta_Y = Y_{11}Y_{22} - Y_{12}Y_{21}$$

$$\Delta_H = H_{11}H_{22} - H_{12}H_{21}$$

$$\Delta_G = G_{11}G_{22} - G_{12}G_{21}$$

$$\Delta_A = A_{11}A_{22} - A_{12}A_{21}$$

$$\Delta_B = B_{11}B_{22} - B_{12}B_{21}$$

## Mạng hai cửa

- Các bộ thông số
- Quan hệ giữa các bộ thông số
- **Phân tích mạch có mạng hai cửa**
- Kết nối các mạng hai cửa
- Mạng  $T$  &  $\Pi$
- Tương hỗ
- Tổng trở vào & hoà hợp tải
- Hàm truyền đạt





# VD1 Phân tích mạch có mạng hai cửa (1)

$$\begin{aligned} \dot{E} &= 220 \angle 0^\circ \text{ V}; & Z &= \begin{bmatrix} 10 & j20 \\ j20 & 40 \end{bmatrix} \\ Z_t &= j50 \Omega; & & \\ \dot{I}_1 &= ? \quad \dot{I}_2 = ? & & \end{aligned}$$

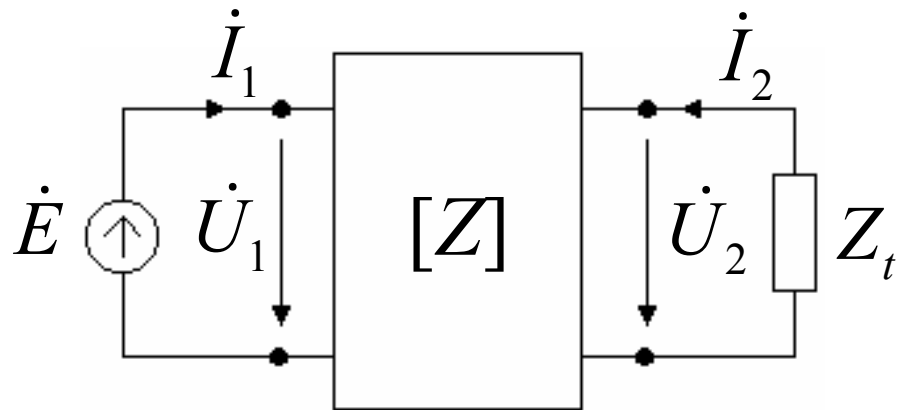

$$\left. \begin{cases} \dot{U}_1 = 10\dot{I}_1 + j20\dot{I}_2 \\ \dot{U}_2 = j20\dot{I}_1 + 40\dot{I}_2 \\ \dot{U}_1 = \dot{E} = 220 \angle 0^\circ \text{ V} \\ \dot{U}_2 = -Z_t \dot{I}_2 = -j50\dot{I}_2 \end{cases} \right\} \rightarrow \begin{cases} 220 \angle 0^\circ = 10\dot{I}_1 + j20\dot{I}_2 \\ -j50\dot{I}_2 = j20\dot{I}_1 + 40\dot{I}_2 \end{cases}$$

$$\rightarrow \begin{cases} \dot{I}_1 = 14,09 + j4,94 \text{ A} \\ \dot{I}_2 = -2,47 - j3,96 \text{ A} \end{cases}$$



VD2

## Phân tích mạch có mạng hai cửa (2)

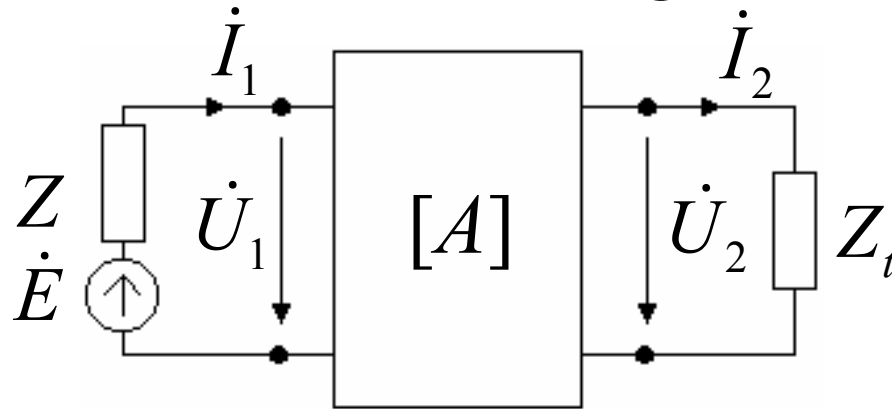

$$\begin{cases} \dot{U}_1 = A_{11}\dot{U}_2 + A_{12}\dot{I}_2 \\ \dot{I}_1 = A_{21}\dot{U}_2 + A_{22}\dot{I}_2 \\ Z\dot{I}_1 + \dot{U}_1 = \dot{E} \\ \dot{U}_2 = Z_t\dot{I}_2 \end{cases}$$



**VD3**

**Phân tích mạch có mạng hai cửa (3)**

$$\left\{ \begin{array}{l} \dot{I}_1 = Y_{11}\dot{U}_1 + Y_{12}\dot{U}_2 \\ \dot{I}_2 = Y_{21}\dot{U}_1 + Y_{22}\dot{U}_2 \\ \dot{I}_n - \dot{I}_1 - \dot{I}_f = 0 \\ \dot{I}_f - \dot{I}_2 - \dot{I}_t = 0 \\ Z_n \dot{I}_n + \dot{U}_1 = \dot{E} \\ Z_f \dot{I}_f - \dot{U}_1 + \dot{U}_2 = 0 \\ \dot{U}_2 - Z_t \dot{I}_t = 0 \end{array} \right.$$

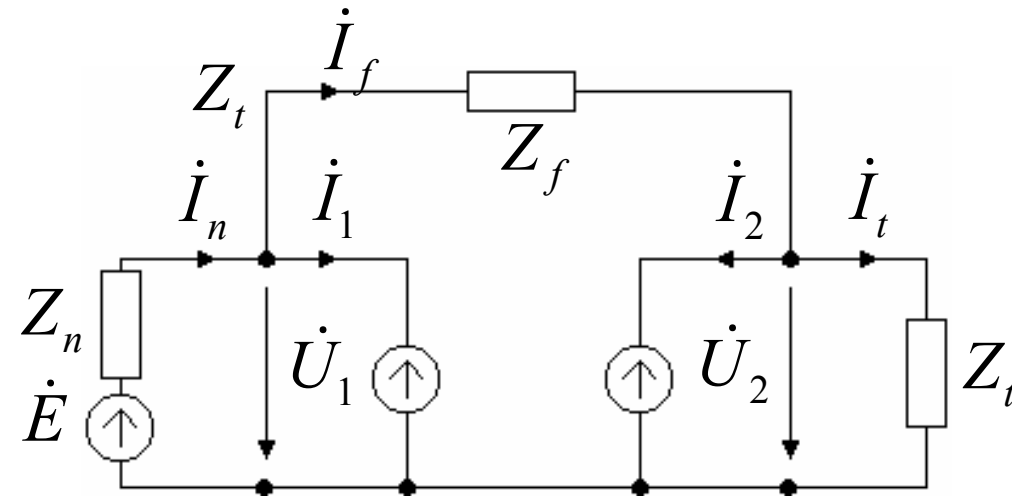
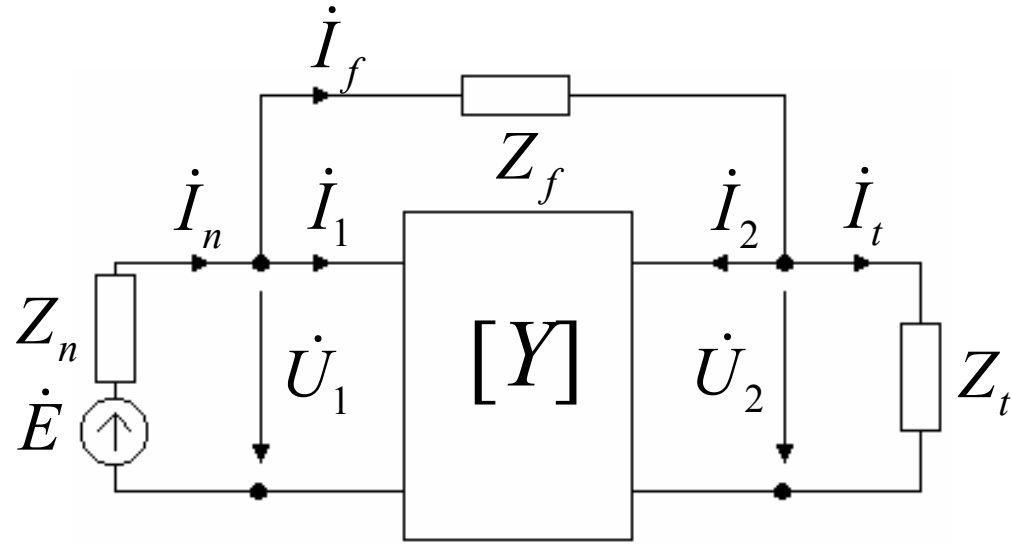



**VD3**

Phân tích mạch có mạng hai cửa (4)

$$\begin{cases} \dot{I}_1 = Y_{11}\dot{U}_1 + Y_{12}\dot{U}_2 = \dot{I}_{vn} - \dot{I}_{vf} \\ \dot{I}_2 = Y_{21}\dot{U}_1 + Y_{22}\dot{U}_2 = \dot{I}_{vf} - \dot{I}_{vt} \\ Z_n \dot{I}_{vn} + \dot{U}_1 = \dot{E} \\ \dot{U}_2 - Z_{vt} \dot{I}_t = 0 \\ Z_f \dot{I}_{vf} - \dot{U}_1 + \dot{U}_2 = 0 \end{cases}$$

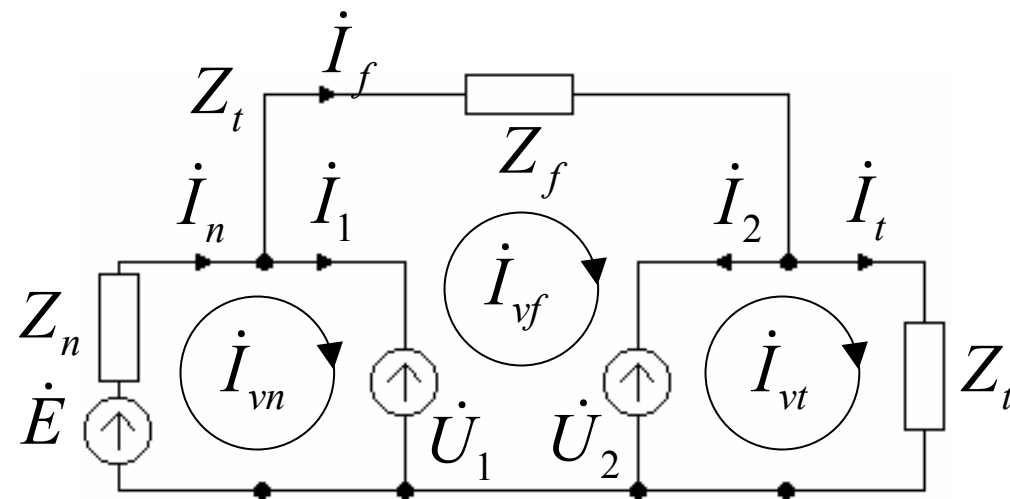
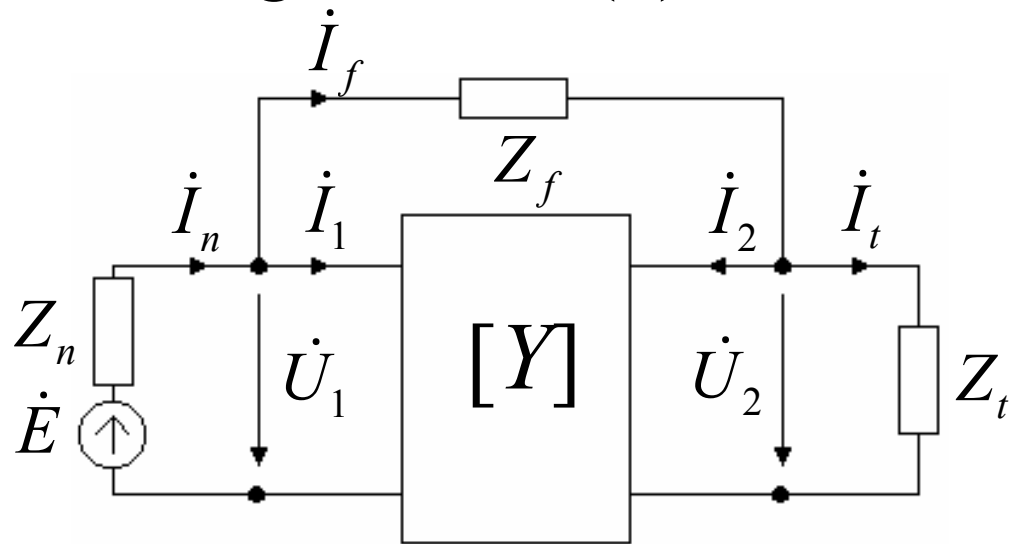



### VD3 Phân tích mạch có mạng hai cửa (5)

$$\left. \begin{aligned} n: \dot{I}_n - \dot{I}_1 - \dot{I}_f &= 0 \\ t: \dot{I}_f - \dot{I}_2 - \dot{I}_t &= 0 \\ \dot{I}_1 &= Y_{11}\dot{U}_1 + Y_{12}\dot{U}_2 = Y_{11}\dot{\phi}_n + Y_{12}\dot{\phi}_t \\ \dot{I}_2 &= Y_{21}\dot{U}_1 + Y_{22}\dot{U}_2 = Y_{21}\dot{\phi}_n + Y_{22}\dot{\phi}_t \\ \dot{I}_n &= \frac{\dot{E} - \dot{\phi}_n}{Z_n} \\ \dot{I}_t &= \frac{\dot{\phi}_t}{Z_t} \\ \dot{I}_f &= \frac{\dot{\phi}_n - \dot{\phi}_t}{Z_f} \end{aligned} \right\}$$

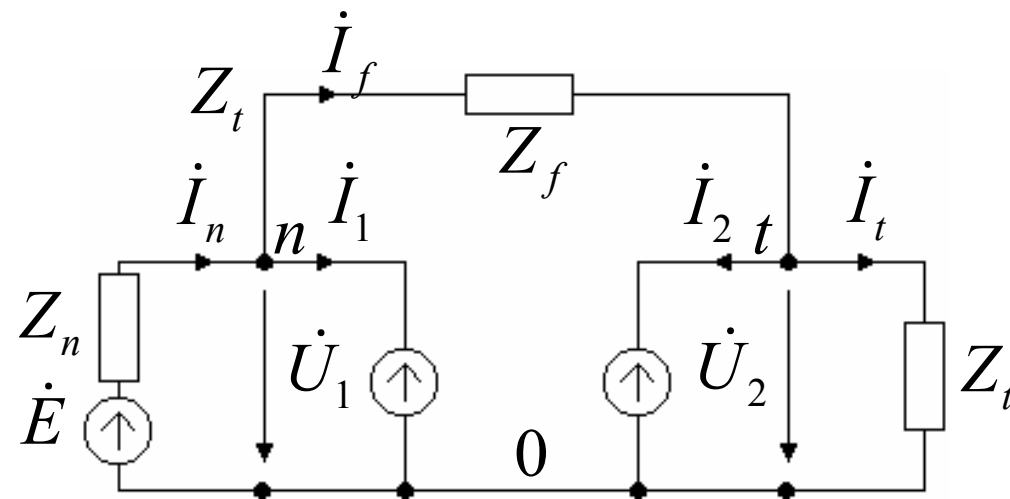
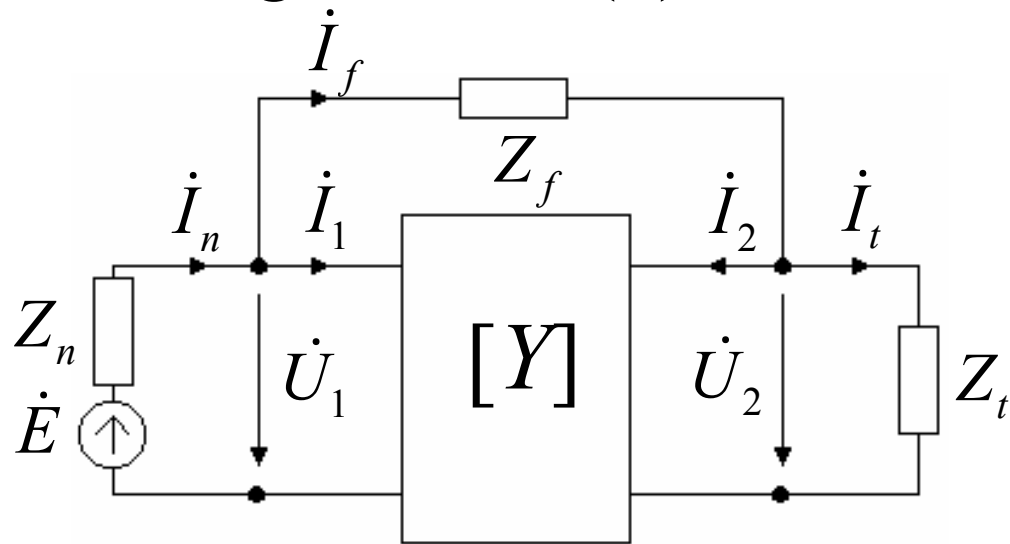

→ hệ phương trình 2 ẩn

## Mạng hai cửa

- Các bộ thông số
- Quan hệ giữa các bộ thông số
- Phân tích mạch có mạng hai cửa
- **Kết nối các mạng hai cửa**
- Mạng  $T$  &  $\Pi$
- Tương hỗ
- Tổng trở vào & hoà hợp tải
- Hàm truyền đạt

## Kết nối các mạng hai cửa (1)

- Một mạng lớn, phức tạp có thể chia thành nhiều mạng con
- Mỗi mạng con có thể mô hình hoá thành mạng hai cửa
- Kết nối các mạng hai cửa này thành mạng ban đầu
- Các kiểu kết nối:
  - Nối tiếp
  - Song song
  - Xâu chuỗi (tầng)
  - Lai



# Kết nối các mạng hai cửa (2)

Nối tiếp

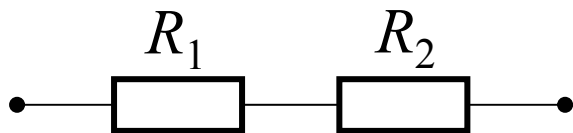

$$\begin{cases} i = i_1 = i_2 \\ u = u_1 + u_2 \end{cases}$$

$$\begin{cases} \dot{I}_1 = \dot{I}_{1a} = \dot{I}_{1b} \\ \dot{U}_1 = \dot{U}_{1a} + \dot{U}_{1b} \\ \dot{I}_2 = \dot{I}_{2a} = \dot{I}_{2b} \\ \dot{U}_2 = \dot{U}_{2a} + \dot{U}_{2b} \end{cases}$$

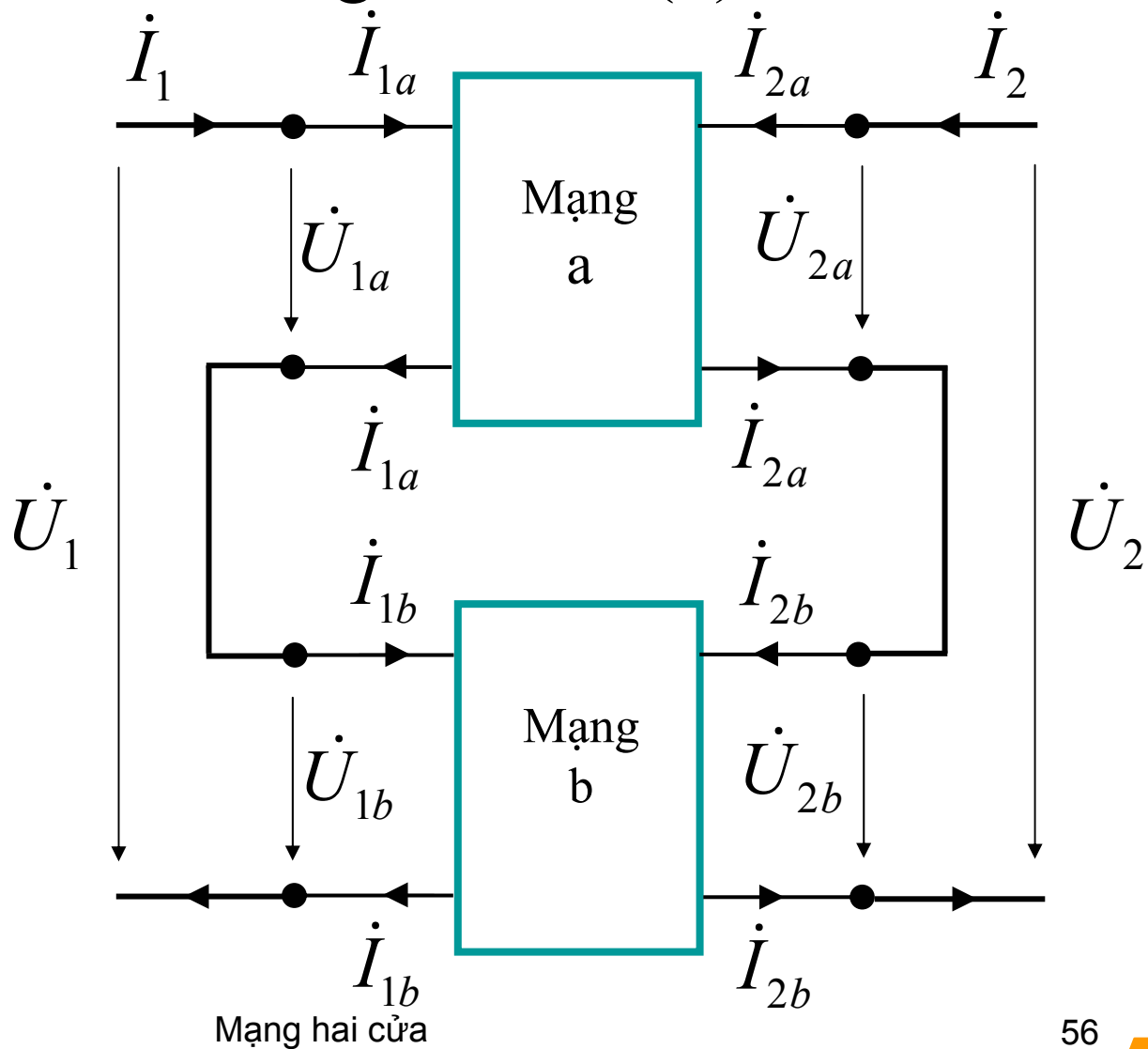



# Kết nối các mạng hai cửa (3)

Nối tiếp

$$\begin{cases} \dot{I}_1 = \dot{I}_{1a} = \dot{I}_{1b} \\ \dot{U}_1 = \dot{U}_{1a} + \dot{U}_{1b} \\ \dot{I}_2 = \dot{I}_{2a} = \dot{I}_{2b} \\ \dot{U}_2 = \dot{U}_{2a} + \dot{U}_{2b} \end{cases}$$

Mạng a:

$$\begin{cases} \dot{U}_{1a} = Z_{11a}\dot{I}_{1a} + Z_{12a}\dot{I}_{2a} \\ \dot{U}_{2a} = Z_{21a}\dot{I}_{1a} + Z_{22a}\dot{I}_{2a} \end{cases}$$

Mạng b:

$$\begin{cases} \dot{U}_{1b} = Z_{11b}\dot{I}_{1b} + Z_{12b}\dot{I}_{2b} \\ \dot{U}_{2b} = Z_{21b}\dot{I}_{1b} + Z_{22b}\dot{I}_{2b} \end{cases}$$

$$\dot{I}_1 = \dot{I}_{1a} = \dot{I}_{1b}$$

$$\dot{I}_2 = \dot{I}_{2a} = \dot{I}_{2b}$$

$$\begin{cases} \dot{U}_{1a} = Z_{11a}\dot{I}_1 + Z_{12a}\dot{I}_2 \\ \dot{U}_{2a} = Z_{21a}\dot{I}_1 + Z_{22a}\dot{I}_2 \\ \dot{U}_{1b} = Z_{11b}\dot{I}_1 + Z_{12b}\dot{I}_2 \\ \dot{U}_{2b} = Z_{21b}\dot{I}_1 + Z_{22b}\dot{I}_2 \end{cases}$$

## Kết nối các mạng hai cửa (4)

Nối tiếp

Mạng a:

$$\begin{cases} \dot{U}_{1a} = Z_{11a}\dot{I}_1 + Z_{12a}\dot{I}_2 \\ \dot{U}_{2a} = Z_{21a}\dot{I}_1 + Z_{22a}\dot{I}_2 \end{cases}$$

Mạng b:

$$\begin{cases} \dot{U}_{1b} = Z_{11b}\dot{I}_1 + Z_{12b}\dot{I}_2 \\ \dot{U}_{2b} = Z_{21b}\dot{I}_1 + Z_{22b}\dot{I}_2 \end{cases}$$

$$\begin{cases} \dot{I}_1 = \dot{I}_{1a} = \dot{I}_{1b} \\ \dot{U}_1 = \dot{U}_{1a} + \dot{U}_{1b} \\ \dot{I}_2 = \dot{I}_{2a} = \dot{I}_{2b} \\ \dot{U}_2 = \dot{U}_{2a} + \dot{U}_{2b} \end{cases}$$

$$\dot{U}_1 = \dot{U}_{1a} + \dot{U}_{1b}$$

$$\dot{U}_2 = \dot{U}_{2a} + \dot{U}_{2b}$$

$$\rightarrow \begin{cases} \dot{U}_1 = \dot{U}_{1a} + \dot{U}_{1b} = (Z_{11a}\dot{I}_1 + Z_{12a}\dot{I}_2) + (Z_{11b}\dot{I}_1 + Z_{12b}\dot{I}_2) \\ \dot{U}_2 = \dot{U}_{2a} + \dot{U}_{2b} = (Z_{21a}\dot{I}_1 + Z_{22a}\dot{I}_2) + (Z_{21b}\dot{I}_1 + Z_{22b}\dot{I}_2) \end{cases}$$

## Kết nối các mạng hai cửa (5)

Nối tiếp

$$\left\{ \begin{array}{l} \dot{I}_1 = \dot{I}_{1a} = \dot{I}_{1b} \\ \dot{U}_1 = \dot{U}_{1a} + \dot{U}_{1b} \\ \dot{I}_2 = \dot{I}_{2a} = \dot{I}_{2b} \\ \dot{U}_2 = \dot{U}_{2a} + \dot{U}_{2b} \end{array} \right.$$

$$\left\{ \begin{array}{l} \dot{U}_1 = \dot{U}_{1a} + \dot{U}_{1b} = (Z_{11a}\dot{I}_1 + Z_{12a}\dot{I}_2) + (Z_{11b}\dot{I}_1 + Z_{12b}\dot{I}_2) \\ \dot{U}_2 = \dot{U}_{1b} + \dot{U}_{2b} = (Z_{21a}\dot{I}_1 + Z_{22a}\dot{I}_2) + (Z_{21b}\dot{I}_1 + Z_{22b}\dot{I}_2) \end{array} \right.$$

$$\Leftrightarrow \left\{ \begin{array}{l} \dot{U}_1 = (Z_{11a} + Z_{11b})\dot{I}_1 + (Z_{12a} + Z_{12b})\dot{I}_2 \\ \dot{U}_2 = (Z_{21a} + Z_{21b})\dot{I}_1 + (Z_{22a} + Z_{22b})\dot{I}_2 \end{array} \right.$$

$$\Leftrightarrow \left\{ \begin{array}{l} \begin{bmatrix} \dot{U}_1 \\ \dot{U}_2 \end{bmatrix} = \begin{bmatrix} Z_{11a} + Z_{11b} & Z_{12a} + Z_{12b} \\ Z_{21a} + Z_{21b} & Z_{22a} + Z_{22b} \end{bmatrix} \begin{bmatrix} \dot{I}_1 \\ \dot{I}_2 \end{bmatrix} = [Z] \begin{bmatrix} \dot{I}_1 \\ \dot{I}_2 \end{bmatrix} \\ [Z_a] = \begin{bmatrix} Z_{11a} & Z_{12a} \\ Z_{21a} & Z_{22a} \end{bmatrix}; [Z_b] = \begin{bmatrix} Z_{11b} & Z_{12b} \\ Z_{21b} & Z_{22b} \end{bmatrix} \end{array} \right.$$

$$\longrightarrow \boxed{[Z] = [Z_a] + [Z_b]}$$



Nối tiếp

Kết nối các mạng hai cửa (6)

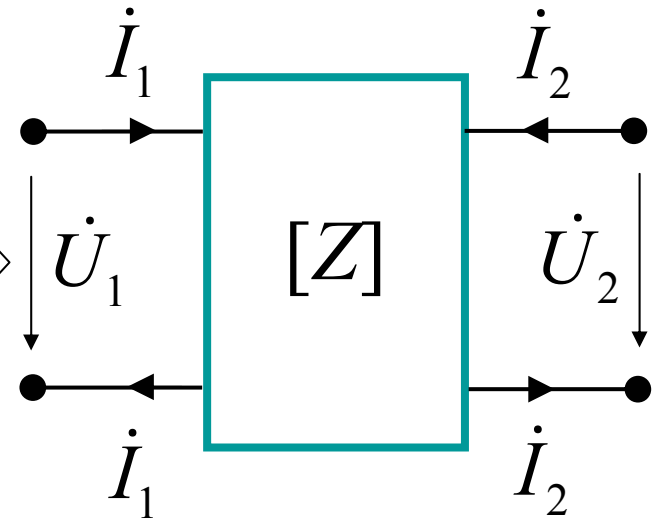
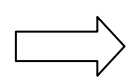
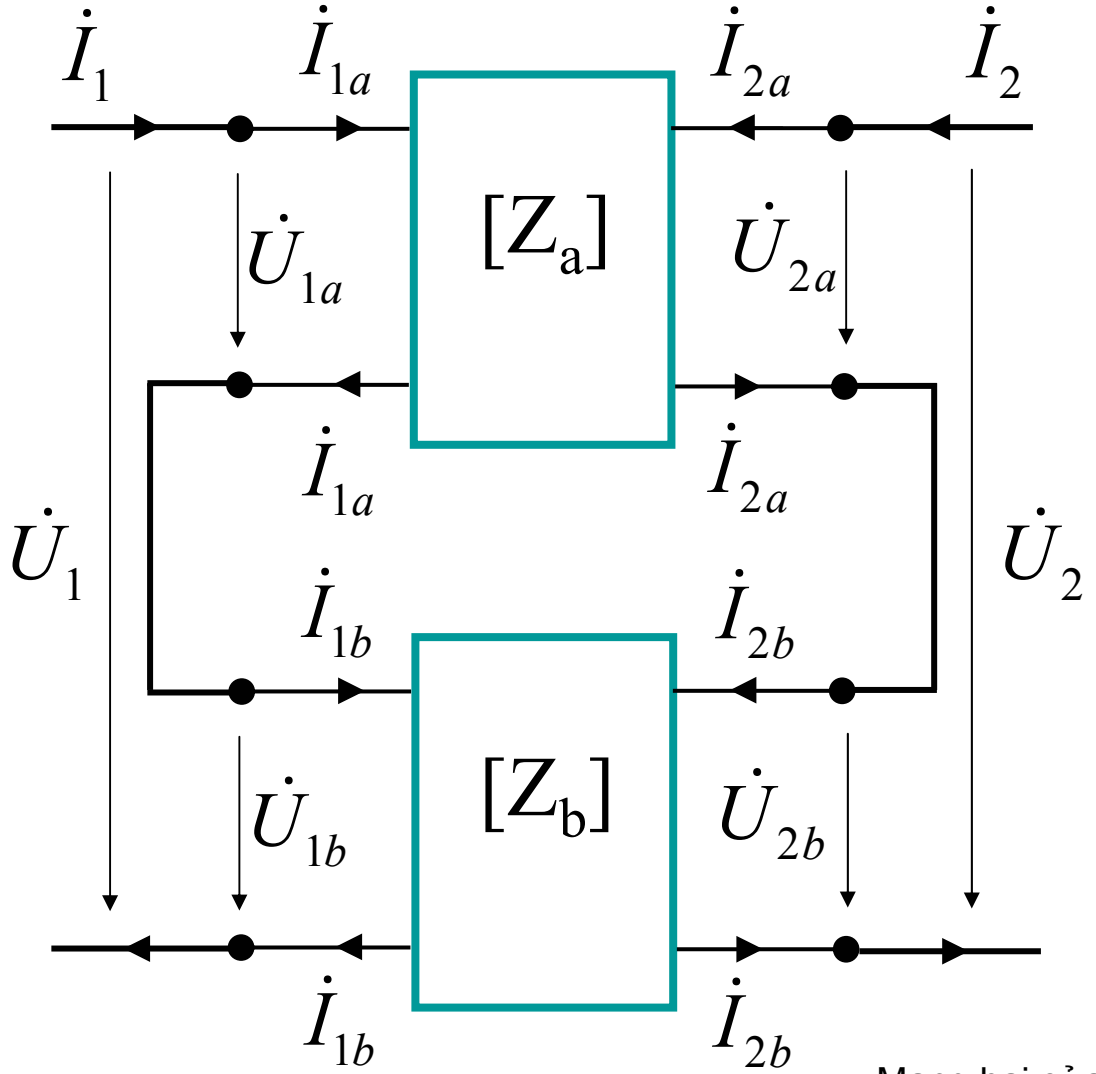

$$[Z] = [Z_a] + [Z_b]$$



Song song

# Kết nối các mạng hai cửa (7)

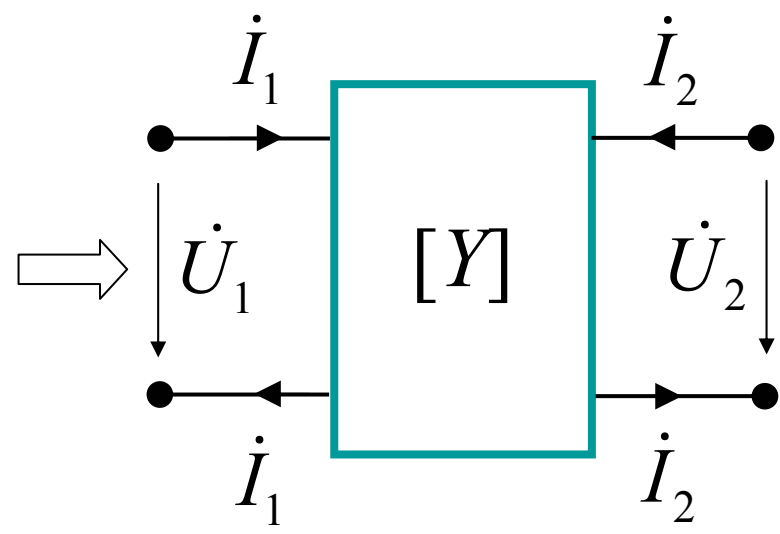
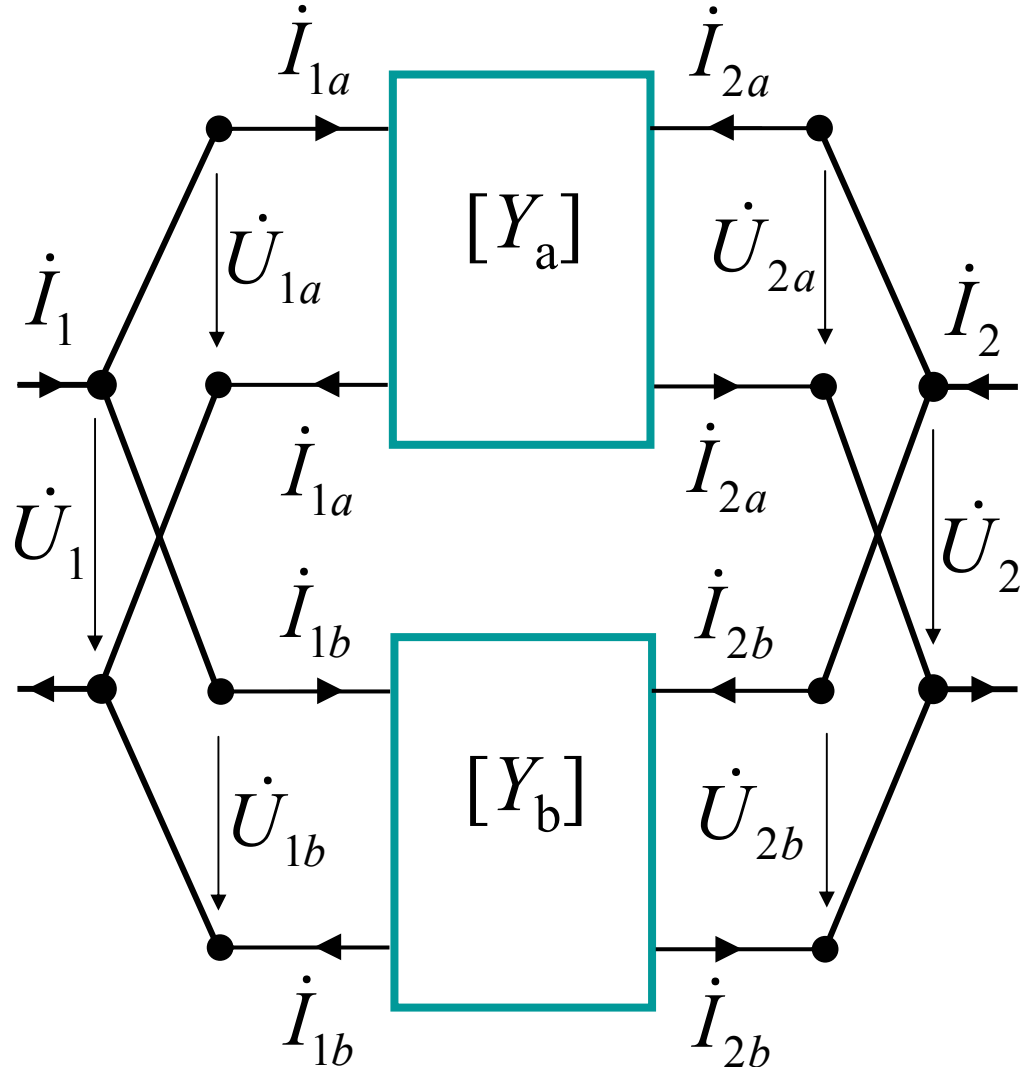

$$[Y] = [Y_a] + [Y_b]$$



Xâu chuỗi

# Kết nối các mạng hai cửa (8)

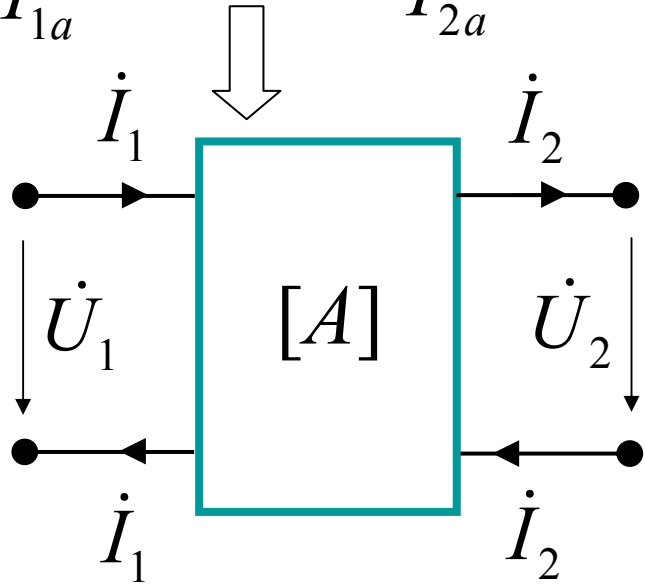
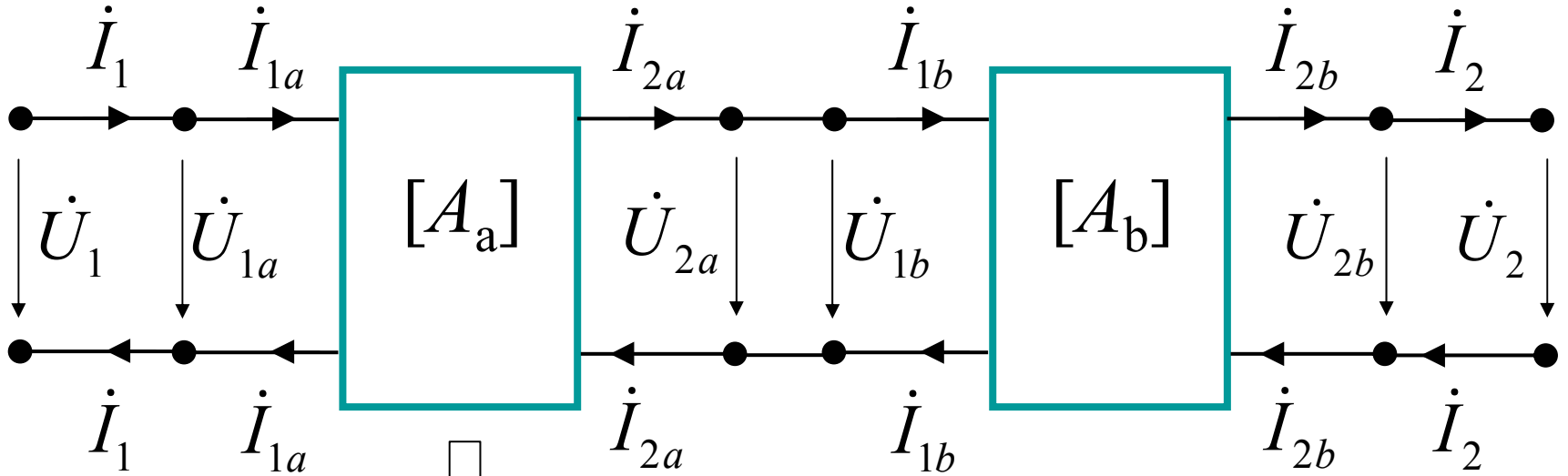

$$[A] = [A_a][A_b]$$

Mạng hai cửa



Lai 1

# Kết nối các mạng hai cửa (9)

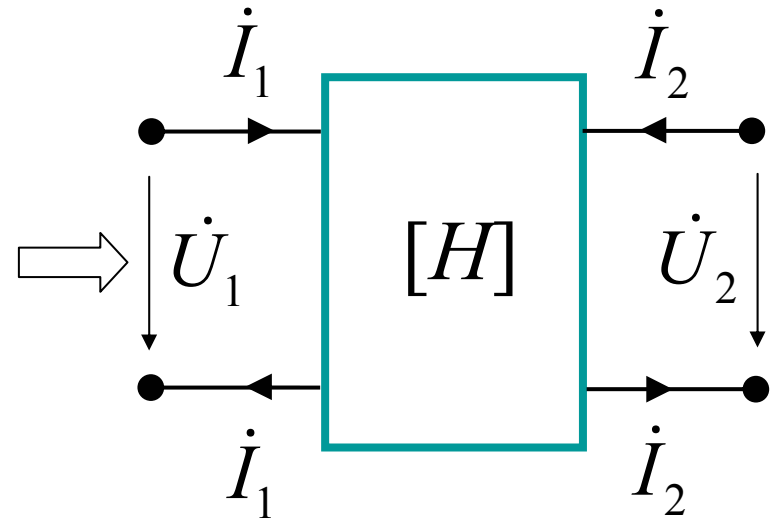
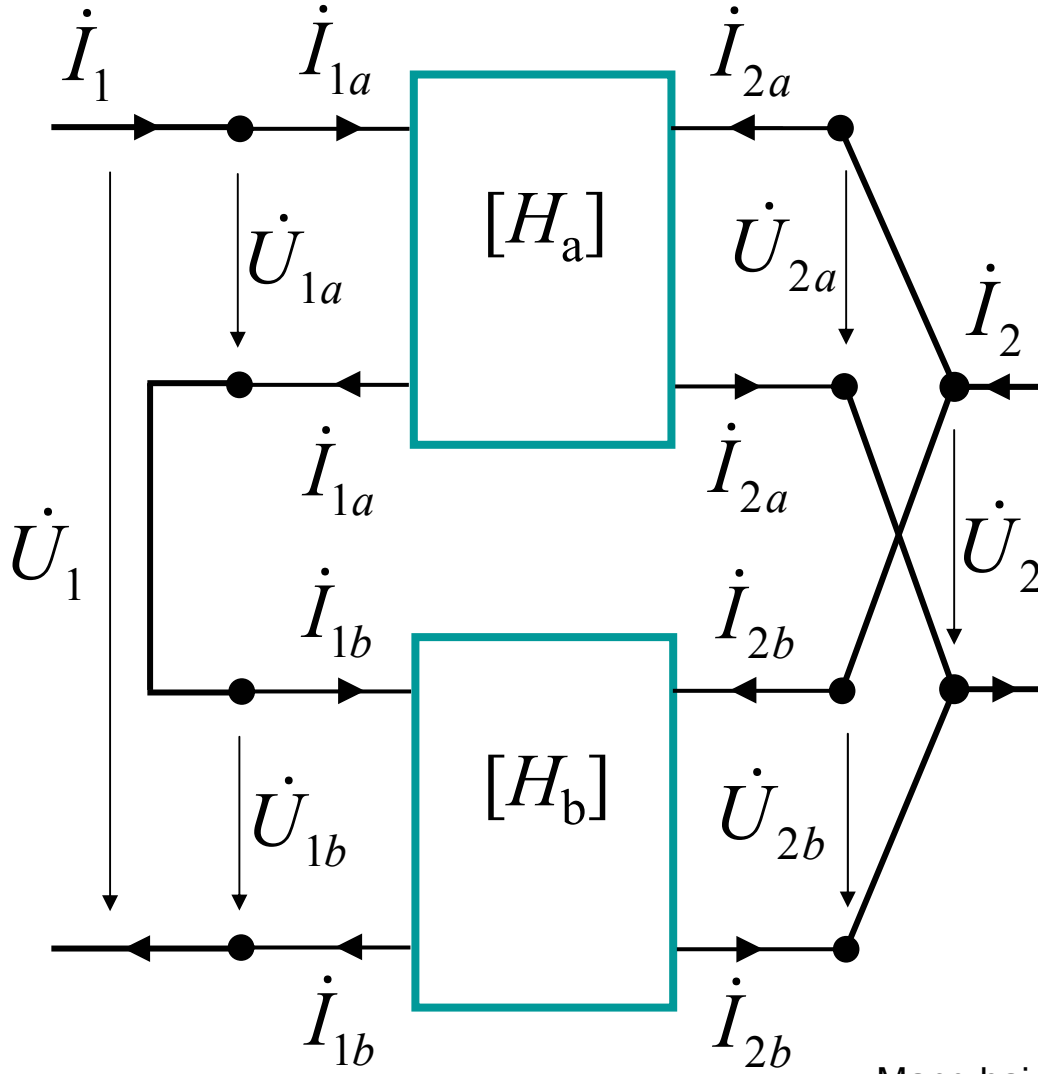

$$[H] = [H_a] + [H_b]$$

Mạng hai cửa



Lai 2

# Kết nối các mạng hai cửa (10)

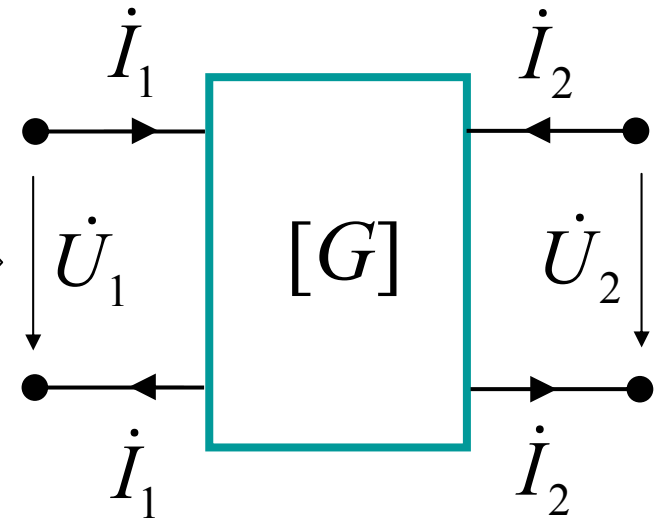
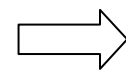
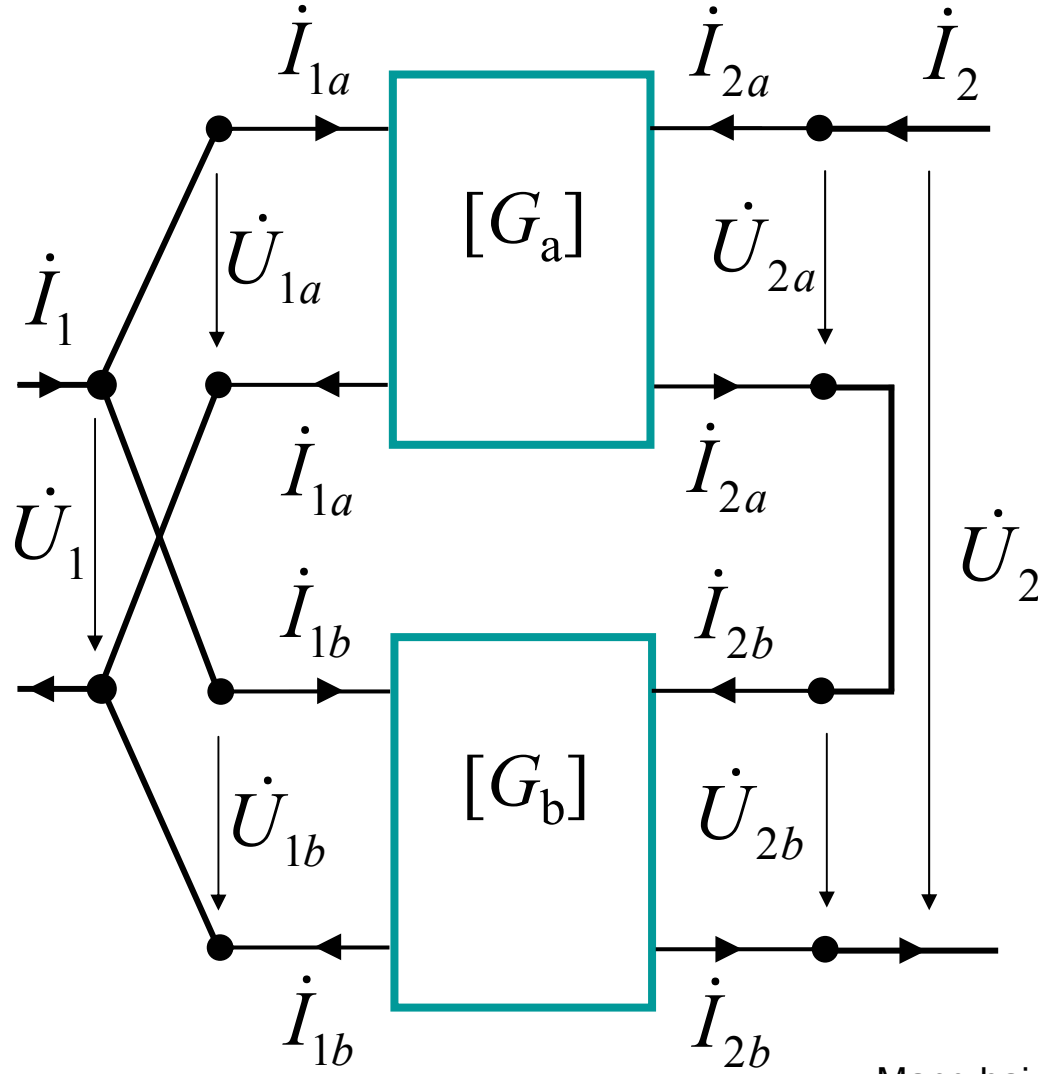

$$[G] = [G_a] + [G_b]$$

Mạng hai cửa





**VD** Kết nối các mạng hai cửa (11)

$$\dot{E} = 100 \angle 0^\circ \text{V}; Z_1 = 5 \Omega; \mathbf{Z} = \begin{bmatrix} 30 & 20 \\ 20 & 50 \end{bmatrix}$$

$$Z_2 = j10 \Omega; Z_3 = -j20 \Omega;$$

Tính các dòng điện.

(Cách 1)

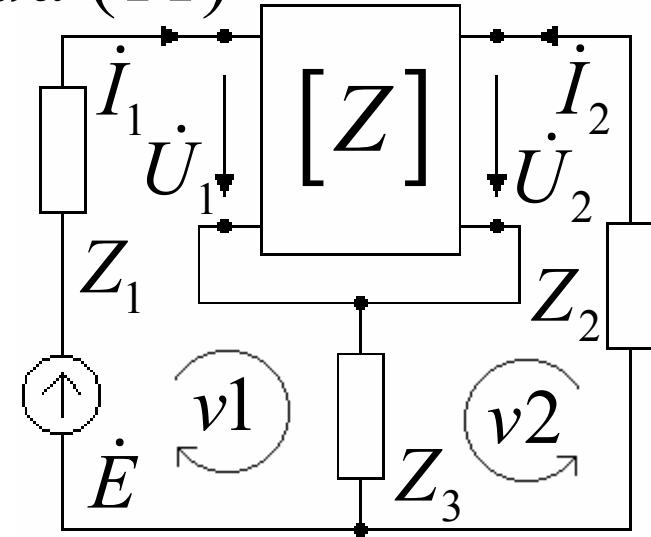

$$\begin{cases} v1: Z_1 \dot{I}_1 + \dot{U}_1 + Z_3 (\dot{I}_1 + \dot{I}_2) = \dot{E} \\ v2: Z_2 \dot{I}_2 + \dot{U}_2 + Z_3 (\dot{I}_1 + \dot{I}_2) = 0 \end{cases} \rightarrow \begin{cases} \dot{I}_1 \\ \dot{I}_2 \\ \dot{I}_{Z3} = \dot{I}_1 + \dot{I}_2 \end{cases}$$

$$\begin{cases} \dot{U}_1 = 30 \dot{I}_1 + 20 \dot{I}_2 \\ \dot{U}_2 = 20 \dot{I}_1 + 50 \dot{I}_2 \end{cases}$$



**VD**

## Kết nối các mạng hai cửa (12)

$$\dot{E} = 100 \angle 0^\circ \text{V}; Z_1 = 5 \Omega; \mathbf{Z} = \begin{bmatrix} 30 & 20 \\ 20 & 50 \end{bmatrix}$$

$$Z_2 = j10 \Omega; Z_3 = -j20 \Omega;$$

Tính các dòng điện.

**(Cách 2)**

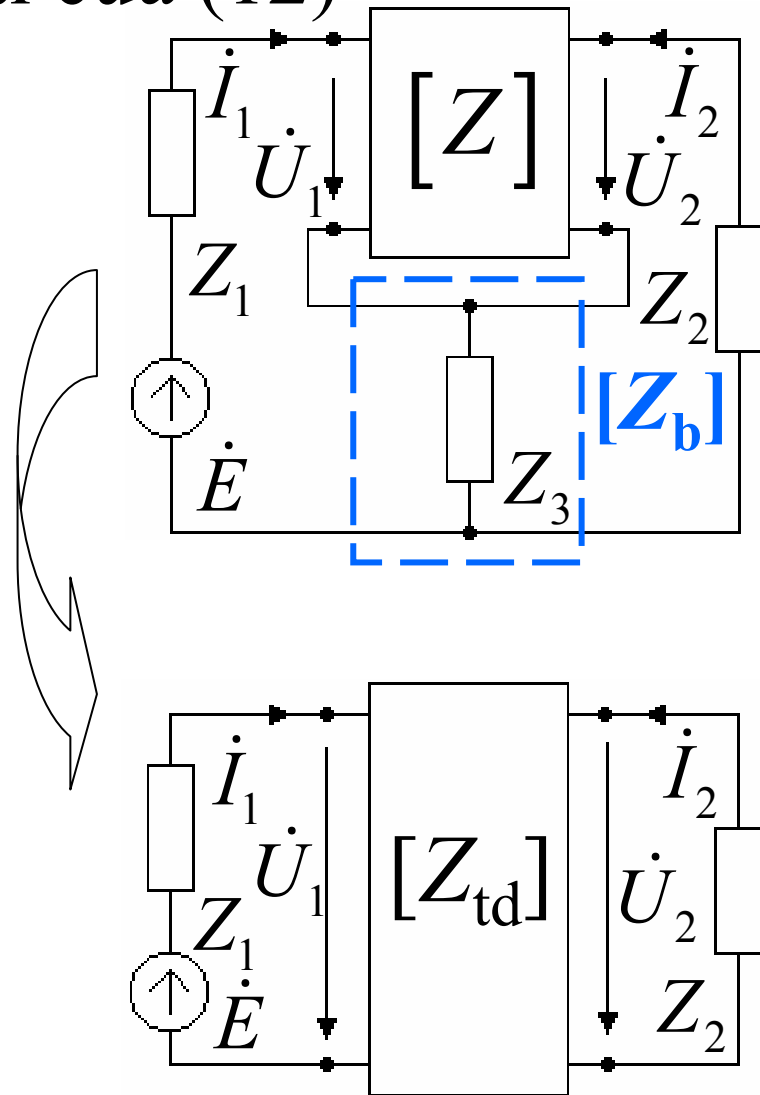

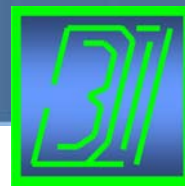

# VD Kết nối các mạng hai cửa (13)

$\dot{E} = 100 \angle 0^\circ \text{V}; Z_1 = 5 \Omega;$   
 $Z_2 = j10 \Omega; Z_3 = -j20 \Omega;$   
 $\mathbf{Z} = \begin{bmatrix} 30 & 20 \\ 20 & 50 \end{bmatrix}$   
 Tính các dòng điện.

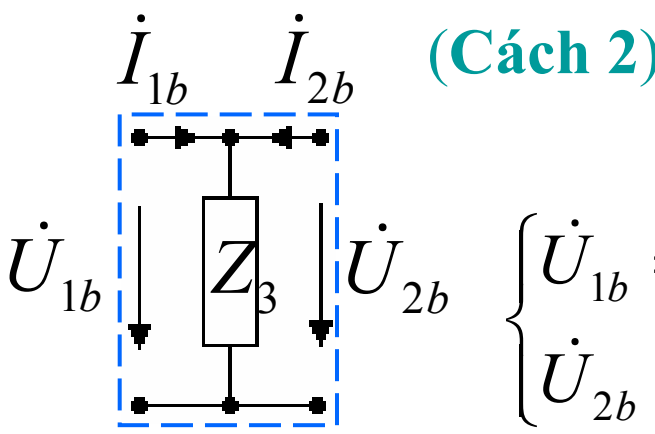
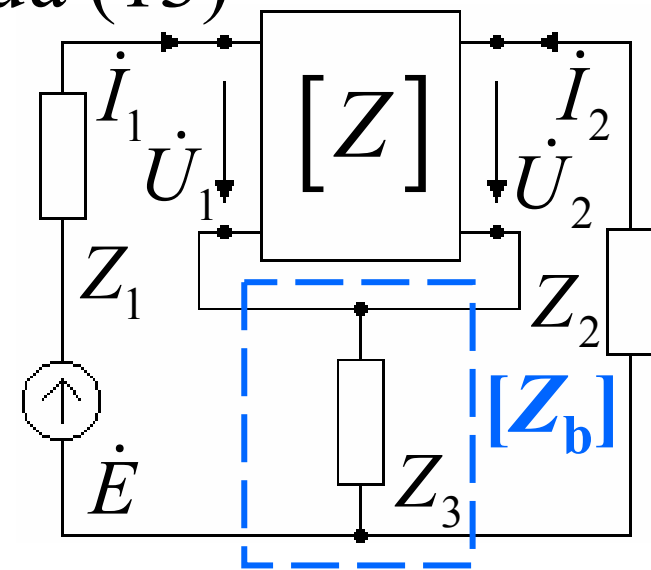

$$\begin{cases} \dot{U}_{1b} = Z_{11b} \dot{I}_{1b} + Z_{12b} \dot{I}_{2b} \\ \dot{U}_{2b} = Z_{21b} \dot{I}_{1b} + Z_{22b} \dot{I}_{2b} \end{cases}$$

$$\dot{U}_{1b} = \dot{U}_{2b} = Z_3 (\dot{I}_{1b} + \dot{I}_{2b}) = Z_3 \dot{I}_{1b} + Z_3 \dot{I}_{2b}$$

$$\mathbf{Z}_b = \begin{bmatrix} Z_3 & Z_3 \\ Z_3 & Z_3 \end{bmatrix} = \begin{bmatrix} -j20 & -j20 \\ -j20 & -j20 \end{bmatrix}$$



## Kết nối các mạng hai cửa (14)

**VD**

$$\dot{E} = 100 \angle 0^\circ \text{V}; Z_1 = 5 \Omega; \mathbf{Z} = \begin{bmatrix} 30 & 20 \\ 20 & 50 \end{bmatrix}$$

$$Z_2 = j10 \Omega; Z_3 = -j20 \Omega;$$

Tính các dòng điện.

(Cách 2)

$$\mathbf{Z}_b = \begin{bmatrix} -j20 & -j20 \\ -j20 & -j20 \end{bmatrix}$$

$$[\mathbf{Z}_{td}] = [\mathbf{Z}] + [\mathbf{Z}_b]$$

$$\rightarrow [\mathbf{Z}_{td}] = \begin{bmatrix} 30 - j20 & 20 - j20 \\ 20 - j20 & 50 - j20 \end{bmatrix}$$

Mạng hai cửa

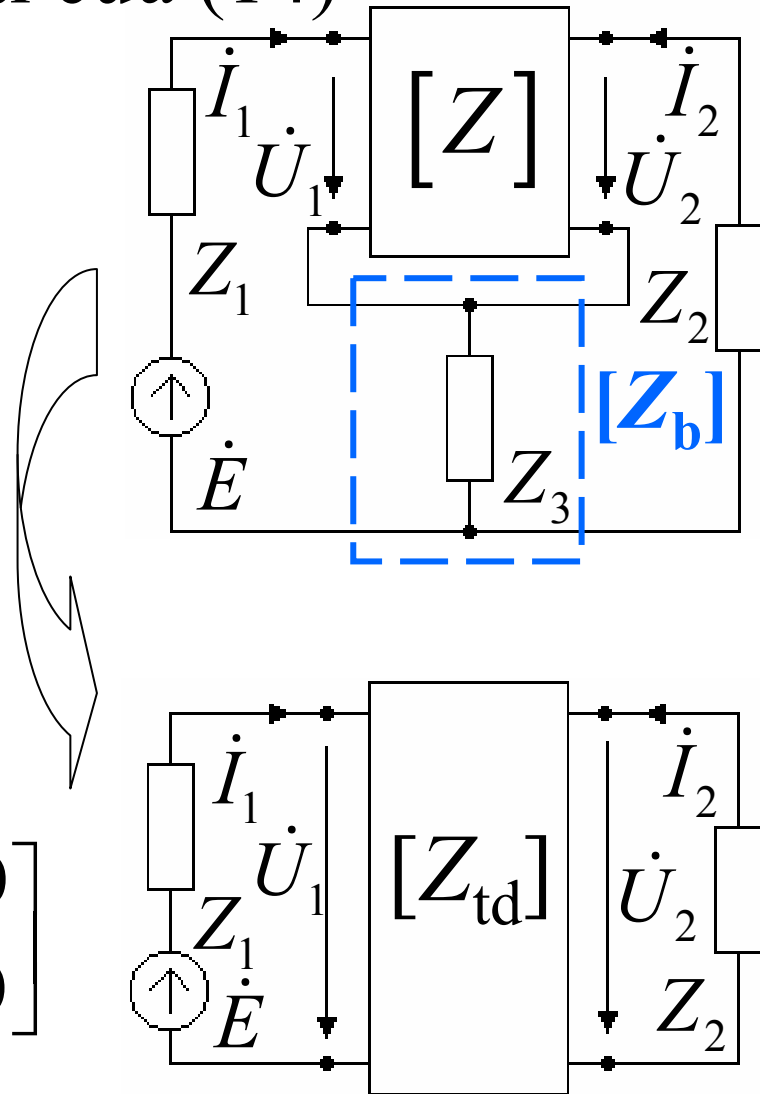



**VD** Kết nối các mạng hai cửa (15)

$$\dot{E} = 100 \angle 0^\circ \text{V}; Z_1 = 5 \Omega; \mathbf{Z} = \begin{bmatrix} 30 & 20 \\ 20 & 50 \end{bmatrix}$$

$$Z_2 = j10 \Omega; Z_3 = -j20 \Omega;$$

Tính các dòng điện.

(Cách 2)

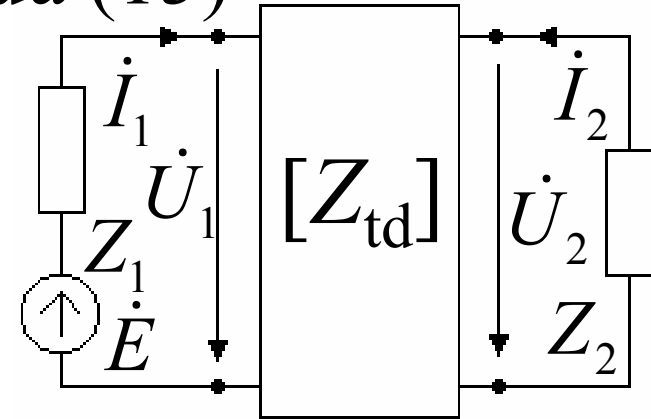

$$\mathbf{Z}_{td} = \begin{bmatrix} 30 - j20 & 20 - j20 \\ 20 - j20 & 50 - j20 \end{bmatrix}$$

$$\begin{cases} Z_1 \dot{I}_1 + \dot{U}_1 = \dot{E} \\ Z_2 \dot{I}_2 + \dot{U}_2 = 0 \\ \dot{U}_1 = (30 - j20)\dot{I}_1 + (20 - j20)\dot{I}_2 \\ \dot{U}_2 = (20 - j20)\dot{I}_1 + (50 - j20)\dot{I}_2 \end{cases} \rightarrow \begin{cases} \dot{I}_1 \\ \dot{I}_2 \end{cases}$$



**VD** Kết nối các mạng hai cửa (16)

$$\dot{E} = 100 \angle 0^\circ \text{V}; Z_1 = 5 \Omega; \mathbf{Z} = \begin{bmatrix} 30 & 20 \\ 20 & 50 \end{bmatrix}$$

$$Z_2 = j10 \Omega; Z_3 = -j20 \Omega;$$

Tính các dòng điện.

(Cách 3)

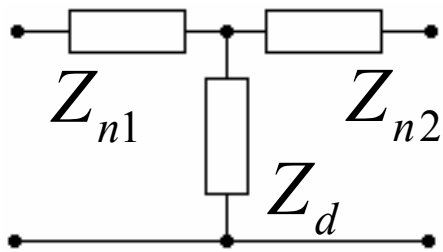

?

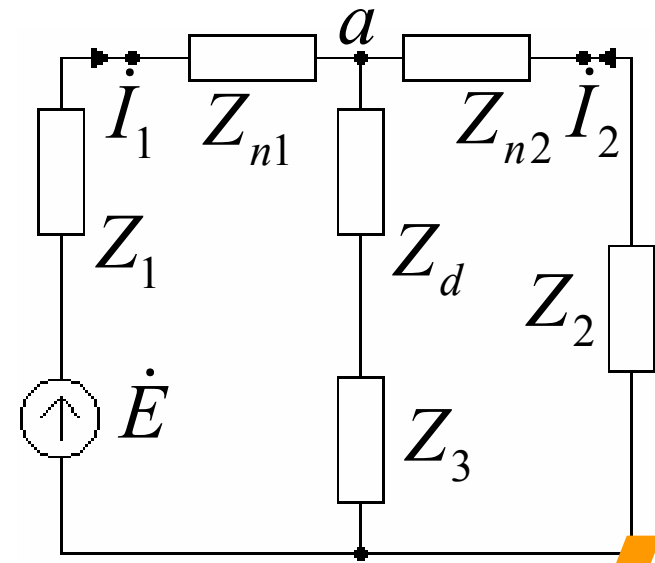
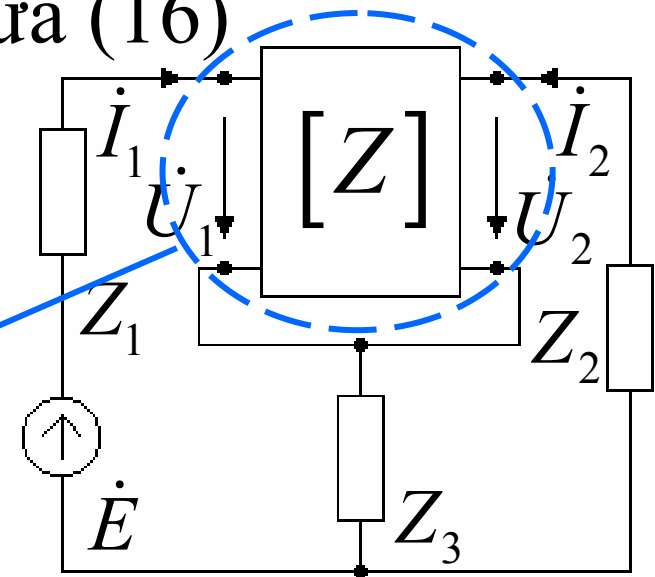

$$\dot{\phi}_a = \frac{\frac{\dot{E}}{Z_1 + Z_{n1}}}{\frac{1}{Z_1 + Z_{n1}} + \frac{1}{Z_d + Z_3} + \frac{1}{Z_2 + Z_{n2}}} \rightarrow \begin{cases} \dot{I}_1 \\ \dot{I}_2 \\ \dot{I}_3 \end{cases}$$

Mạng hai cửa

## Mạng hai cửa

- Các bộ thông số
- Quan hệ giữa các bộ thông số
- Phân tích mạch có mạng hai cửa
- Kết nối các mạng hai cửa
- **Mạng T & Π**
- Tương hỗ
- Tổng trở vào & hoà hợp tải
- Hàm truyền đạt



## Mạng T & $\Pi$ (1)

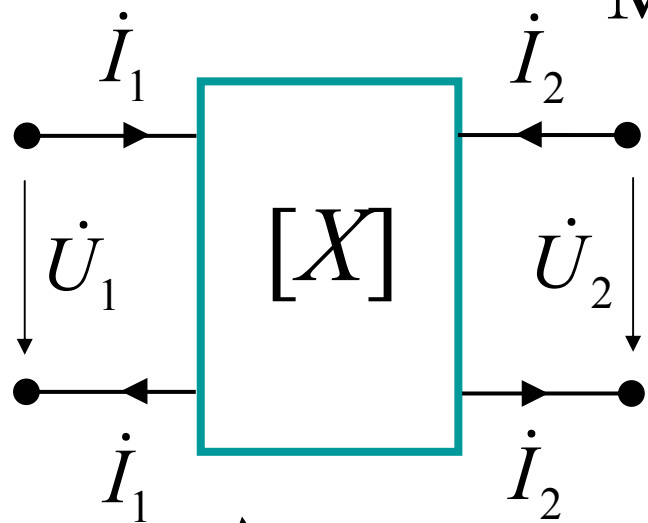

1. Tính bộ thông số  $[X']$  của mạng T (hoặc  $\Pi$ )
2.  $[X] = [X']$
3.  $\rightarrow$  tính được giá trị của các tổng trở của mạng T (hoặc  $\Pi$ )

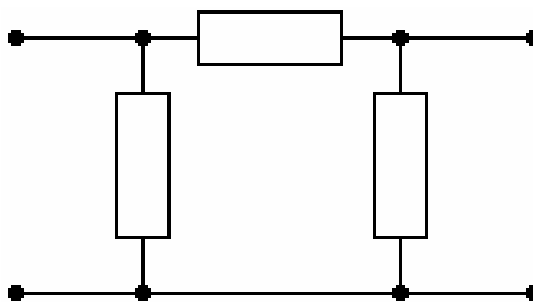
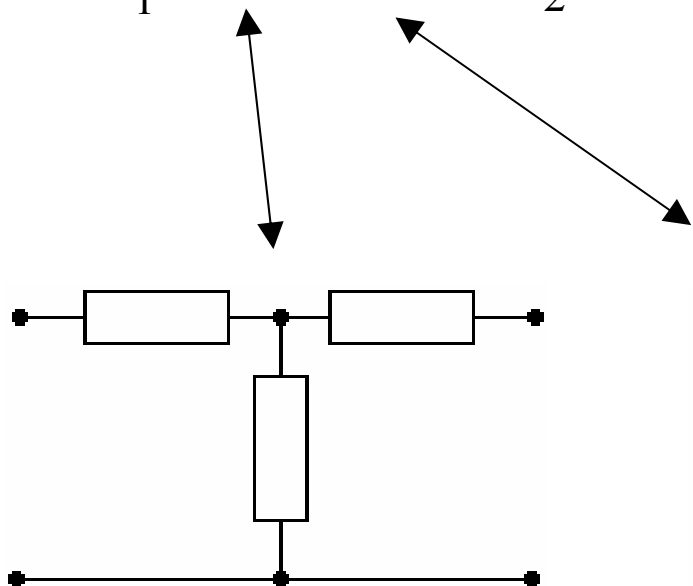

Mạng hai cửa





**VD**

## Mạng T & Π (2)

$$Z = \begin{bmatrix} 30 & 20 \\ 20 & 50 \end{bmatrix}; \text{ Tìm mạng T tương đương.}$$

$$\begin{cases} \dot{U}_1 = Z'_{11}\dot{I}_1 + Z'_{12}\dot{I}_2 \\ \dot{U}_2 = Z'_{21}\dot{I}_1 + Z'_{22}\dot{I}_2 \end{cases}$$

$$\left. \begin{aligned} Z'_{11} &= \frac{\dot{U}_1}{\dot{I}_1} \Big|_{\dot{I}_2=0} \\ \dot{U}_1 &= (Z_{n1} + Z_d)\dot{I}_1 \end{aligned} \right\} \rightarrow$$

$$\rightarrow Z'_{11} = \frac{\dot{U}_1}{\dot{I}_1} = \frac{(Z_{n1} + Z_d)\dot{I}_1}{\dot{I}_1} = Z_{n1} + Z_d$$

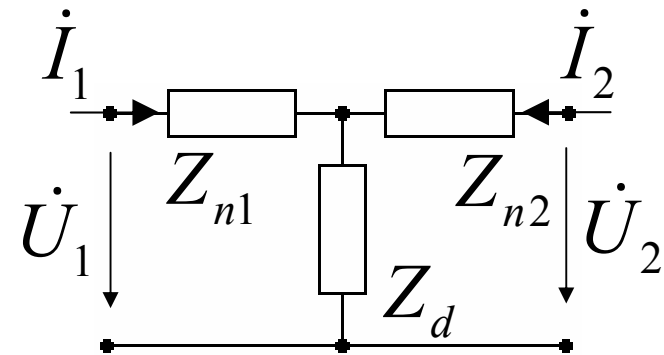
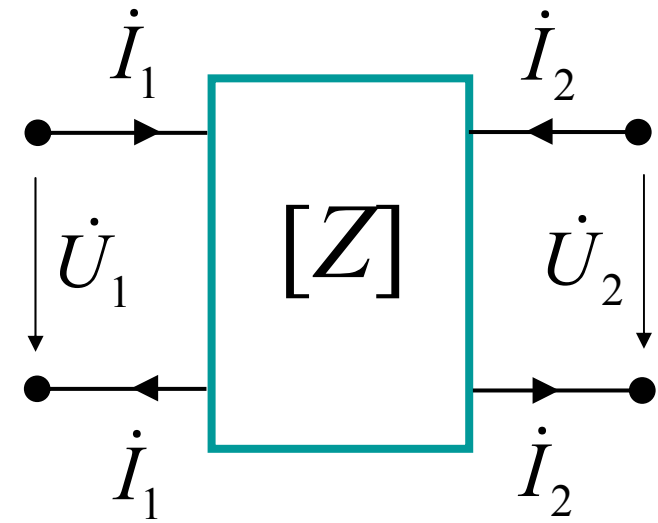



**VD**

### Mạng T & Π (3)

$$Z = \begin{bmatrix} 30 & 20 \\ 20 & 50 \end{bmatrix}; \text{ Tìm mạng T tương đương.}$$

$$\begin{cases} \dot{U}_1 = Z'_{11}\dot{I}_1 + Z'_{12}\dot{I}_2 \\ \dot{U}_2 = Z'_{21}\dot{I}_1 + Z'_{22}\dot{I}_2 \end{cases}$$

$$\left. \begin{aligned} Z'_{21} &= \left. \frac{\dot{U}_2}{\dot{I}_1} \right|_{\dot{I}_2=0} \\ \dot{U}_2 &= Z_d \dot{I}_1 \end{aligned} \right\} \rightarrow$$

$$\rightarrow Z'_{21} = \frac{\dot{U}_2}{\dot{I}_1} = \frac{Z_d \dot{I}_1}{\dot{I}_1} = Z_d$$

Mạng hai cửa

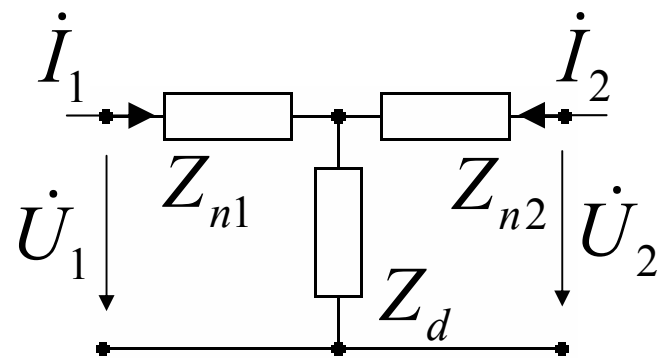
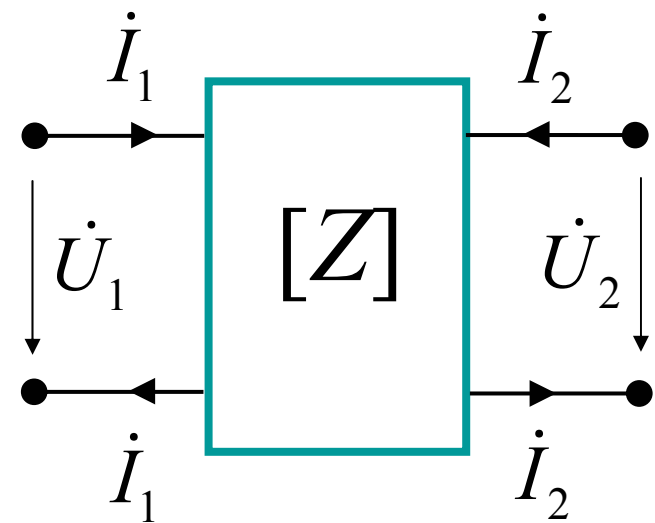



**VD**

### Mạng T & Π (4)

$$Z = \begin{bmatrix} 30 & 20 \\ 20 & 50 \end{bmatrix}; \text{ Tìm mạng T tương đương.}$$

$$\begin{cases} \dot{U}_1 = Z'_{11}\dot{I}_1 + Z'_{12}\dot{I}_2 \\ \dot{U}_2 = Z'_{21}\dot{I}_1 + Z'_{22}\dot{I}_2 \end{cases}$$

$$\left. \begin{aligned} Z'_{12} &= \frac{\dot{U}_1}{\dot{I}_2} \Big|_{\dot{I}_1=0} \\ \dot{U}_1 &= Z_d \dot{I}_2 \end{aligned} \right\} \rightarrow$$

$$\rightarrow Z'_{12} = \frac{\dot{U}_1}{\dot{I}_2} = \frac{Z_d \dot{I}_2}{\dot{I}_2} = Z_d$$

Mạng hai cửa

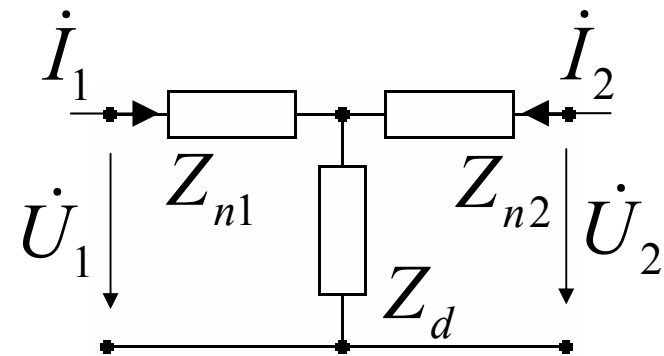
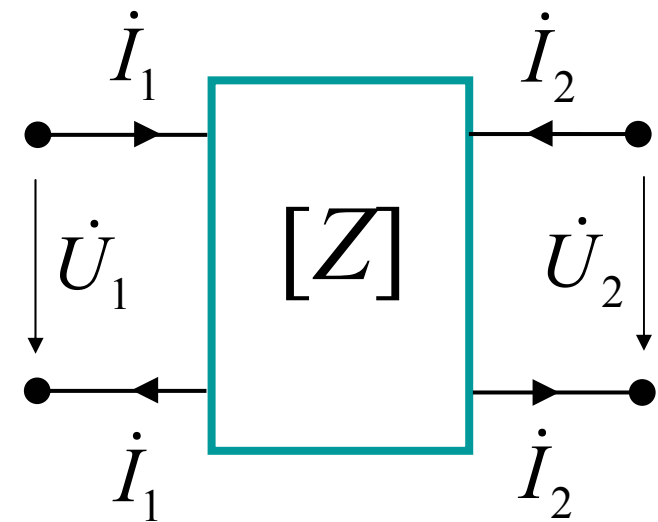



**VD**

## Mạng T & Π (5)

$$Z = \begin{bmatrix} 30 & 20 \\ 20 & 50 \end{bmatrix}; \text{ Tìm mạng T tương đương.}$$

$$\begin{cases} \dot{U}_1 = Z'_{11}\dot{I}_1 + Z'_{12}\dot{I}_2 \\ \dot{U}_2 = Z'_{21}\dot{I}_1 + Z'_{22}\dot{I}_2 \end{cases}$$

$$\left. \begin{aligned} Z'_{22} &= \frac{\dot{U}_2}{\dot{I}_2} \Big|_{\dot{I}_1=0} \\ \dot{U}_2 &= (Z_{n2} + Z_d)\dot{I}_2 \end{aligned} \right\} \rightarrow$$

$$\rightarrow Z'_{22} = \frac{\dot{U}_2}{\dot{I}_2} = \frac{(Z_{n2} + Z_d)\dot{I}_2}{\dot{I}_2} = Z_{n2} + Z_d$$

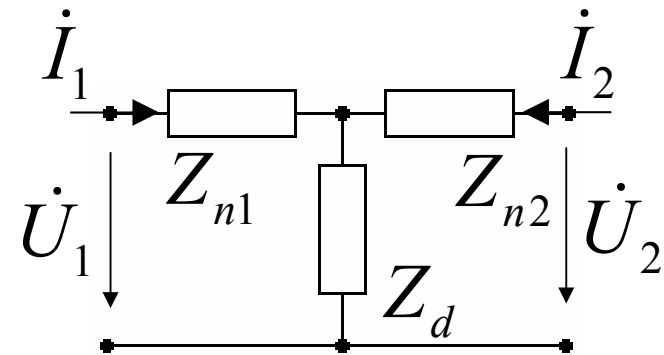
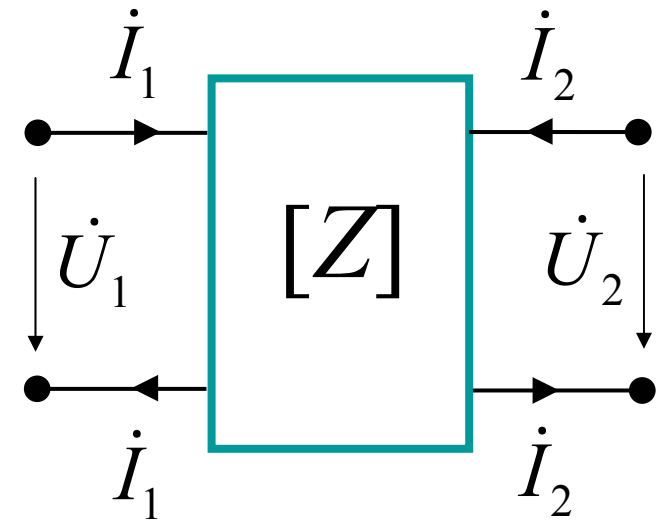



**VD**

## Mạng T & Π (6)

$$Z = \begin{bmatrix} 30 & 20 \\ 20 & 50 \end{bmatrix}; \text{ Tìm mạng T tương đương.}$$

$$\begin{cases} \dot{U}_1 = Z'_{11}\dot{I}_1 + Z'_{12}\dot{I}_2 \\ \dot{U}_2 = Z'_{21}\dot{I}_1 + Z'_{22}\dot{I}_2 \end{cases}$$

$$Z'_{11} = Z_{n1} + Z_d$$

$$Z'_{12} = Z_d$$

$$Z'_{21} = Z_d$$

$$Z'_{22} = Z_{n2} + Z_d$$

$$\rightarrow Z' = \begin{bmatrix} Z_{n1} + Z_d & Z_d \\ Z_d & Z_{n2} + Z_d \end{bmatrix}$$

Mạng hai cửa

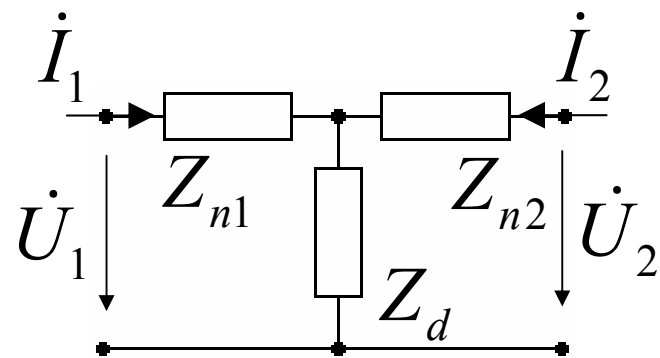
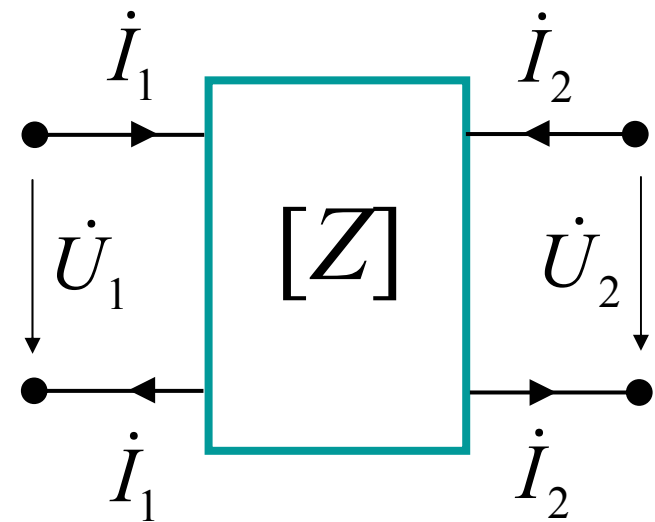



**VD**

## Mạng T & Π (7)

$$Z = \begin{bmatrix} 30 & 20 \\ 20 & 50 \end{bmatrix}; \text{ Tìm mạng T tương đương.}$$

$$Z' = \begin{bmatrix} Z_{n1} + Z_d & Z_d \\ Z_d & Z_{n2} + Z_d \end{bmatrix}$$

$$Z = \begin{bmatrix} 30 & 20 \\ 20 & 50 \end{bmatrix}$$

$$Z = Z'$$

$$\rightarrow \begin{cases} Z_{n1} + Z_d = 30 \\ Z_d = 20 \\ Z_{n2} + Z_d = 50 \end{cases} \rightarrow \begin{cases} Z_{n1} = 10\Omega \\ Z_d = 20\Omega \\ Z_{n2} = 30\Omega \end{cases}$$

Mạng hai cửa

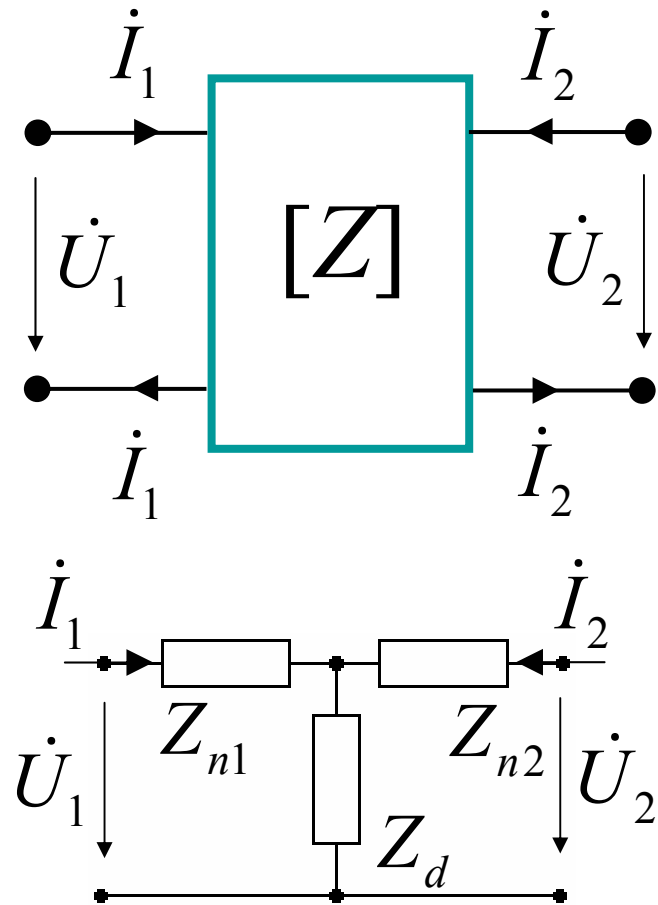



# Mạng T & Π (8)

$$Z_T = \left[ \begin{array}{cc} Z_{n1} + Z_d & Z_d \\ Z_d & Z_{n2} + Z_d \end{array} \right]$$

$$Z = \left[ \begin{array}{cc} Z_{11} & Z_{12} \\ Z_{21} & Z_{22} \end{array} \right]$$

$$\rightarrow \begin{cases} Z_{11} = Z_{n1} + Z_d \\ Z_{12} = Z_{21} = Z_d \\ Z_{22} = Z_{n2} + Z_d \end{cases}$$

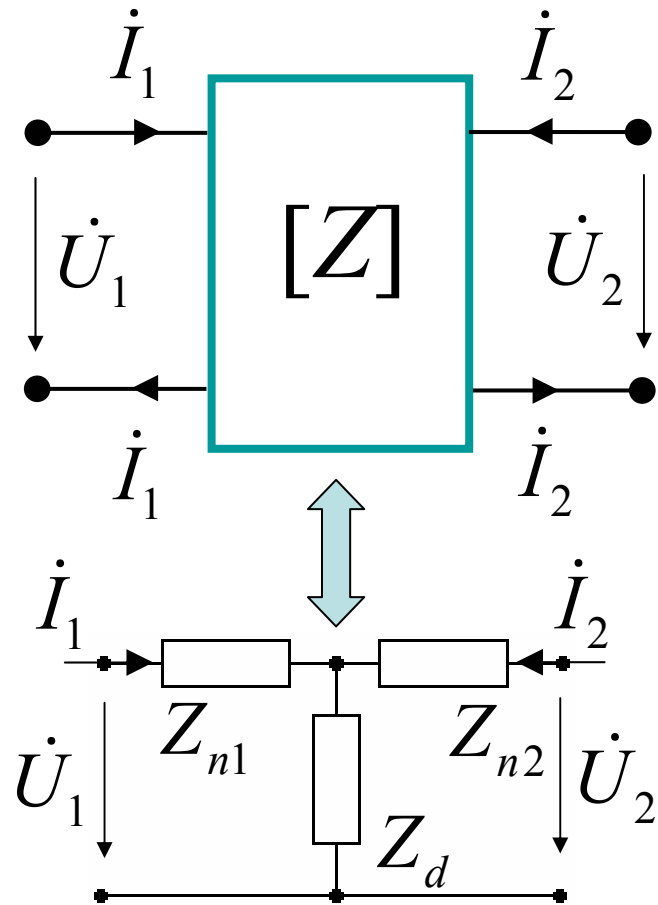

Bộ số  $[Z]$  của một mạng hai cửa tuyến tính không nguồn luôn thoả mãn  $Z_{12} = Z_{21}$



## Mạng T & Π (9)

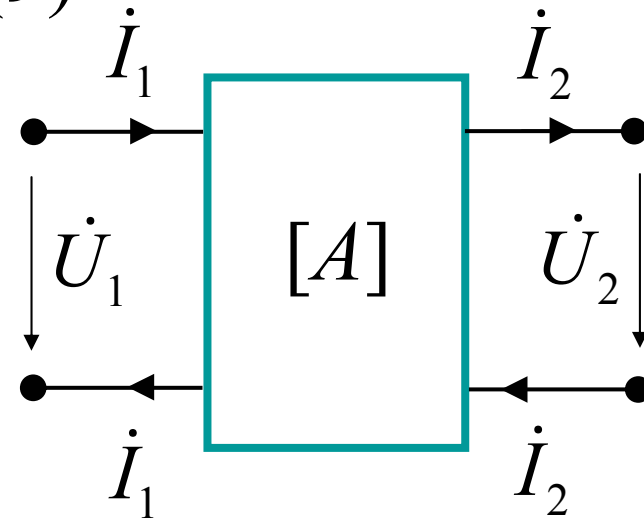
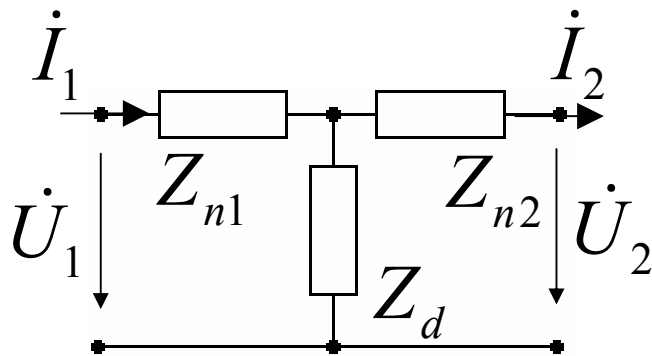

$$Z_{n1} = \frac{A_{11} - 1}{A_{21}}$$

$$Z_d = \frac{1}{A_{21}}$$

$$Z_{n2} = \frac{A_{22} - 1}{A_{21}}$$

$$A_{11} = 1 + \frac{Z_{n1}}{Z_d}$$

$$A_{21} = \frac{1}{Z_d}$$

$$A_{12} = Z_{n1} + Z_{n2} + \frac{Z_{n1}Z_{n2}}{Z_d}$$

$$A_{22} = \frac{Z_{n2}}{Z_d}$$





## Mạng T & Π (10)

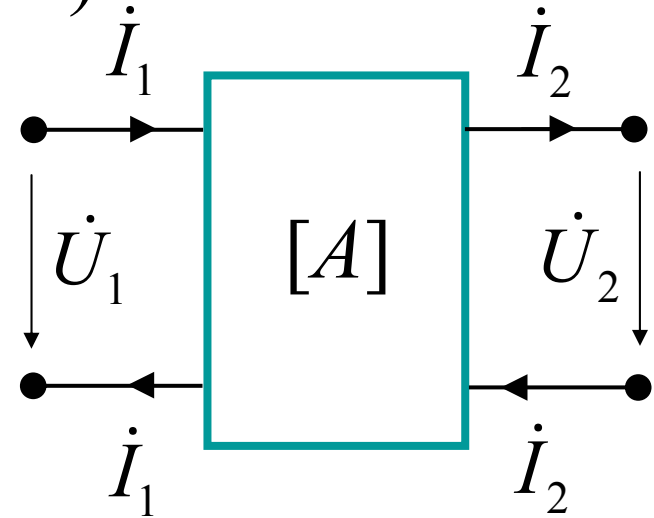
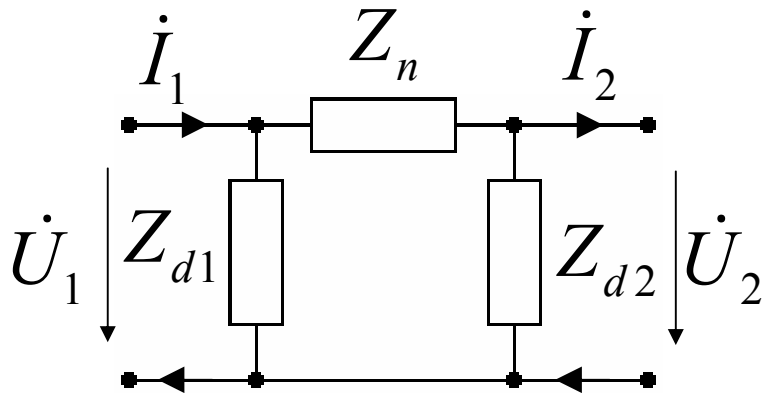

$$Z_{d1} = \frac{A_{12}}{A_{22} - 1}$$

$$Z_n = A_{12}$$

$$Z_{d2} = \frac{A_{12}}{A_{11} - 1}$$

$$A_{11} = 1 + \frac{Z_n}{Z_{d2}}$$

$$A_{12} = Z_d$$

$$A_{21} = \frac{Z_{d1} + Z_n + Z_{d2}}{Z_{d1} Z_{d2}}$$

$$A_{22} = 1 + \frac{Z_n}{Z_{d1}}$$

## Mạng hai cửa

- Các bộ thông số
- Quan hệ giữa các bộ thông số
- Phân tích mạch có mạng hai cửa
- Kết nối các mạng hai cửa
- Mạng  $T$  &  $\Pi$
- **Tương hỗ**
- Tổng trở vào & hoà hợp tải
- Hàm truyền đạt

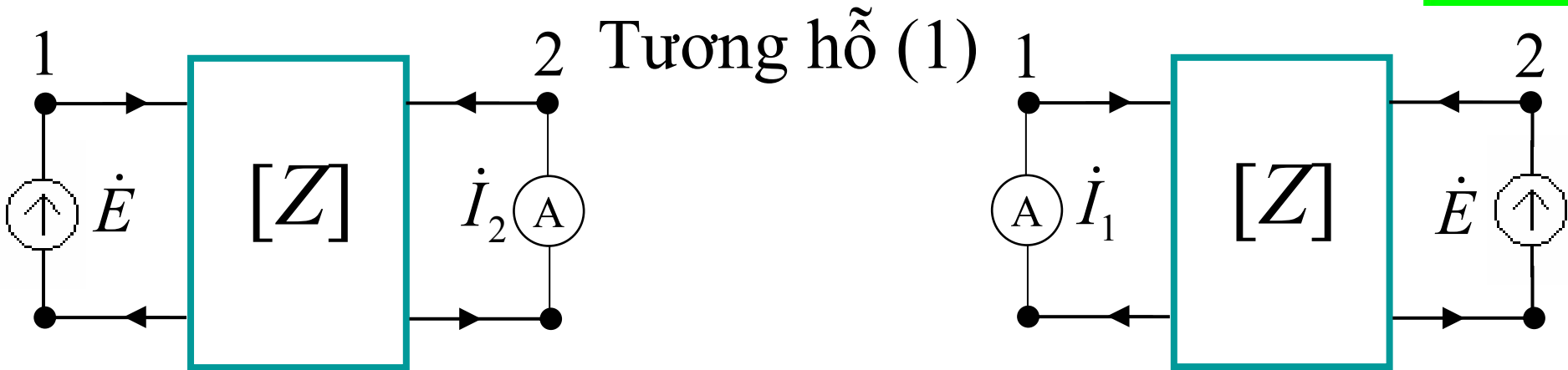

Mạng hai cửa gọi là tương hỗ nếu  $\dot{I}_1 = \dot{I}_2$

$$\left\{ \begin{array}{l} \dot{U}_1 = Z_{11}\dot{I}_1 + Z_{12}\dot{I}_2 \\ \dot{U}_2 = Z_{21}\dot{I}_1 + Z_{22}\dot{I}_2 \\ \dot{U}_1 = \dot{E} \\ \dot{U}_2 = 0 \end{array} \right.$$

$$\rightarrow \dot{I}_2 = \frac{Z_{21}\dot{E}}{Z_{21}Z_{12} - Z_{11}Z_{22}}$$

$$\left\{ \begin{array}{l} \dot{U}_1 = Z_{11}\dot{I}_1 + Z_{12}\dot{I}_2 \\ \dot{U}_2 = Z_{21}\dot{I}_1 + Z_{22}\dot{I}_2 \\ \dot{U}_2 = \dot{E} \\ \dot{U}_1 = 0 \end{array} \right.$$

$$\rightarrow \dot{I}_1 = \frac{Z_{12}\dot{E}}{Z_{21}Z_{12} - Z_{11}Z_{22}}$$

Mạng hai cửa



## Tương hỗ (2)

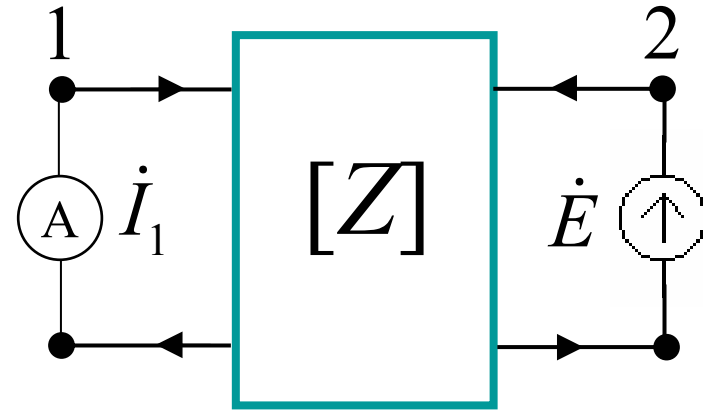
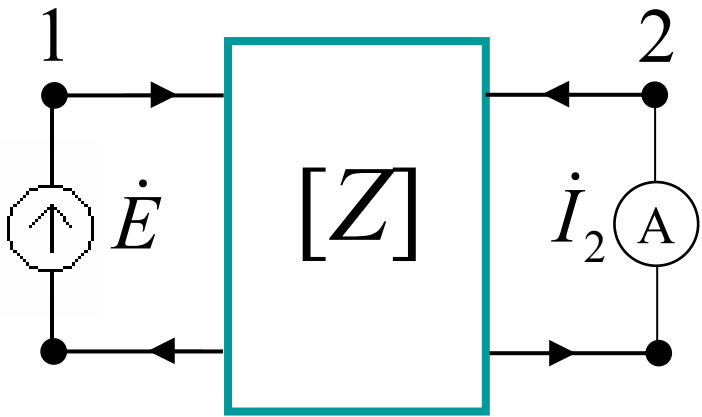

Mạng hai cửa gọi là tương hỗ nếu  $\dot{I}_1 = \dot{I}_2$

$$\dot{I}_2 = \frac{Z_{21}\dot{E}}{Z_{21}Z_{12} - Z_{11}Z_{22}}$$

$$\dot{I}_1 = \frac{Z_{12}\dot{E}}{Z_{21}Z_{12} - Z_{11}Z_{22}}$$

Mạng hai cửa gọi là tương hỗ nếu  $Z_{12} = Z_{21}$



### Tương hỗ (3)

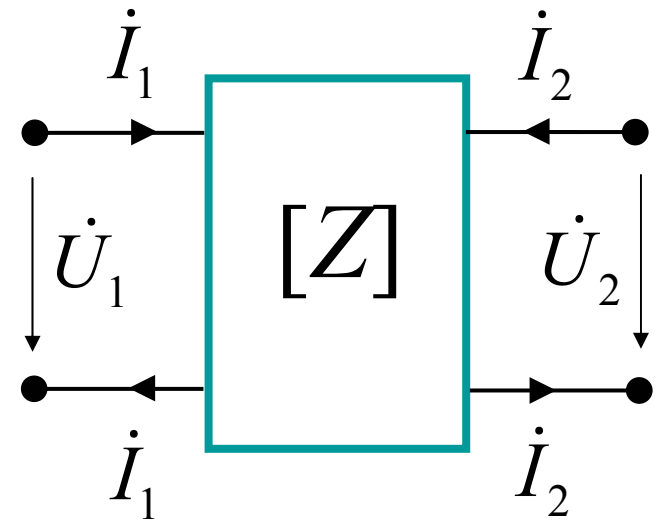

Mạng hai cửa gọi là tương hỗ nếu  $Z_{12} = Z_{21}$   
 Bộ số  $[Z]$  của một mạng hai cửa tuyến tính không  
 nguồn luôn thoả mãn  $Z_{12} = Z_{21}$

→ Mạng hai cửa tuyến tính không nguồn luôn có tính tương hỗ



# Tương hỗ (4)

**VD**

Tính dòng qua  $R_5$ .

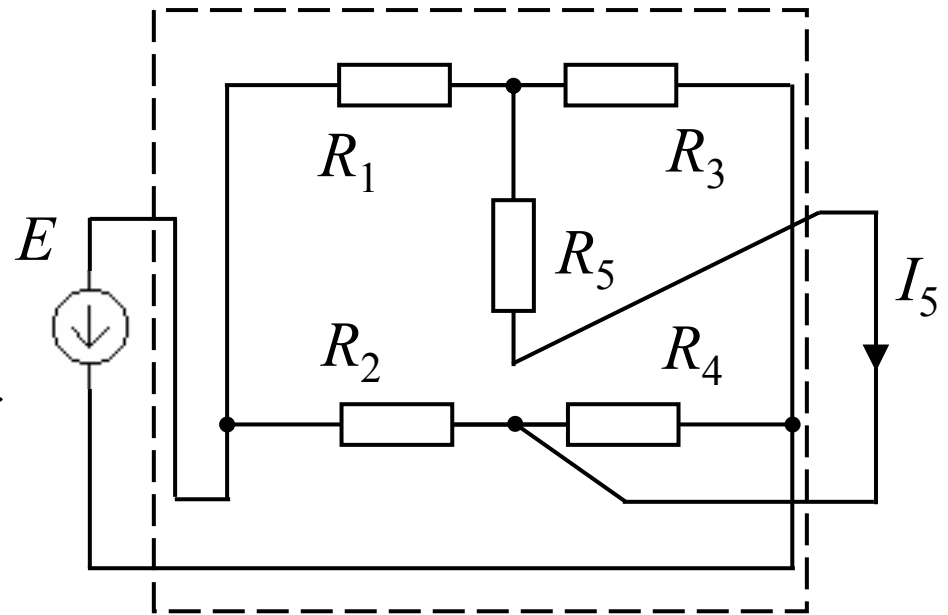
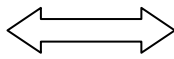
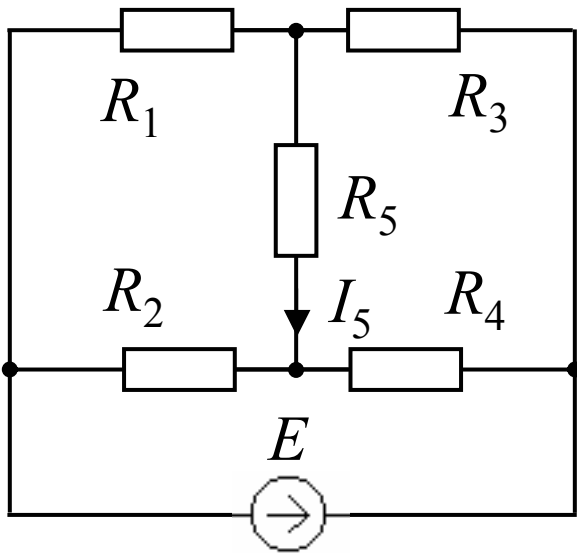



# Tương hỗ (5)

**VD**

Tính dòng qua  $R_5$ .

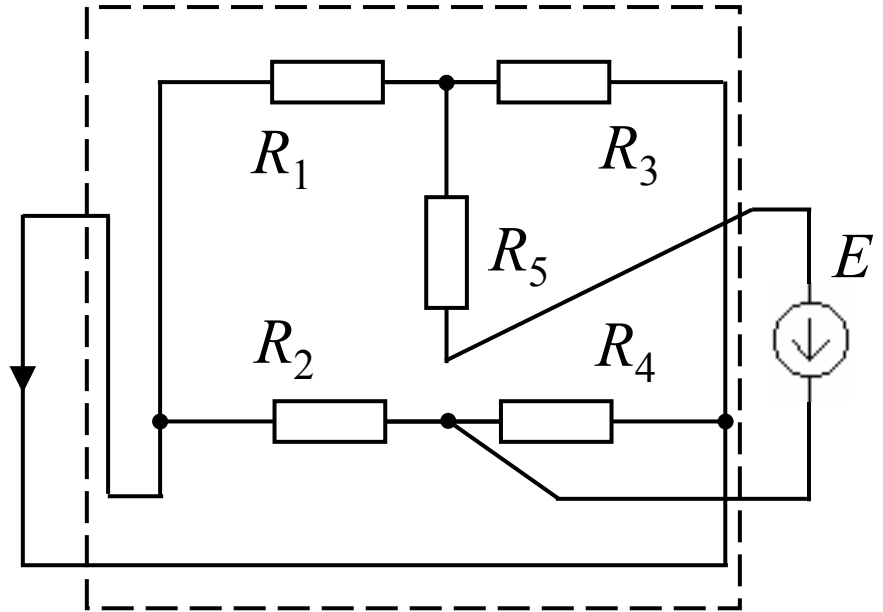
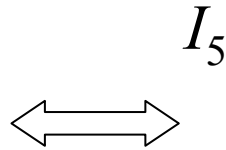
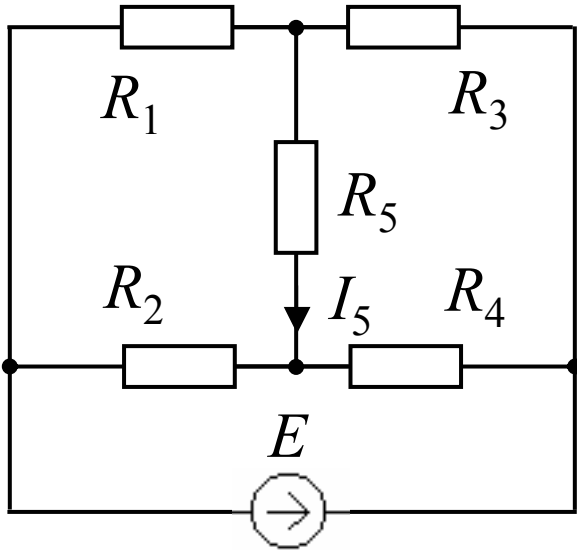



# Tương hỗ (6)

**VD**

Tính dòng qua  $R_5$ .

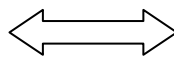
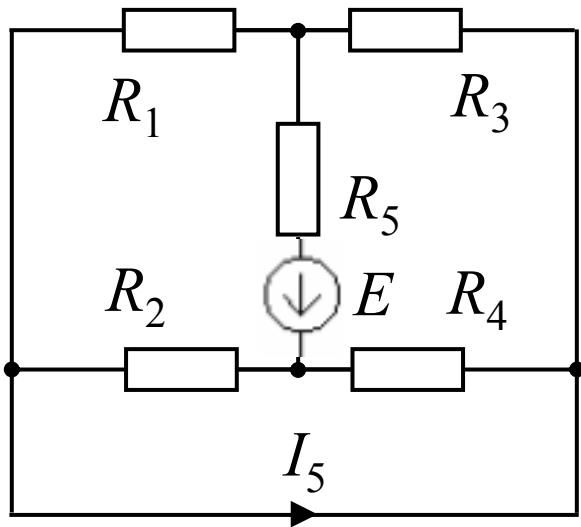

$I_5$

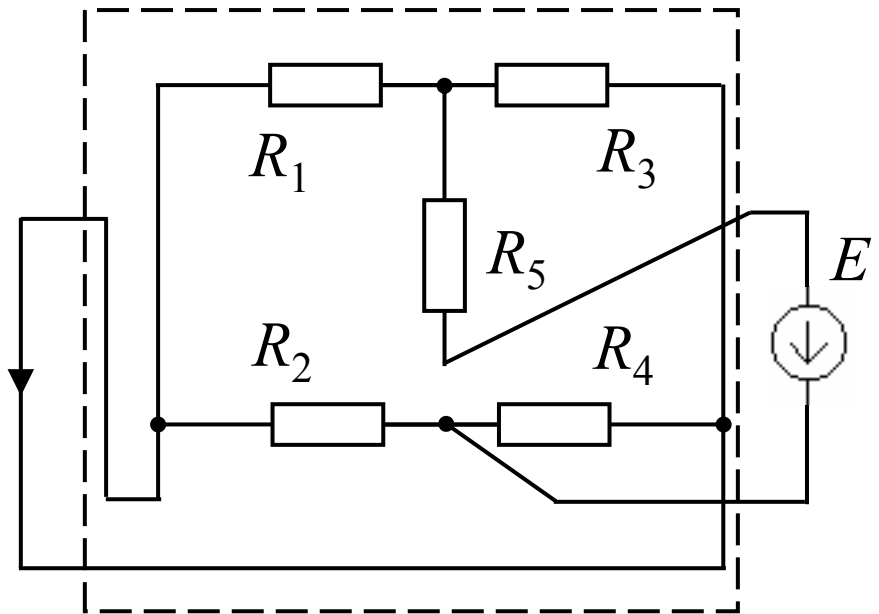





# Tương hỗ (7)

**VD**

Tính dòng qua  $R_5$ .

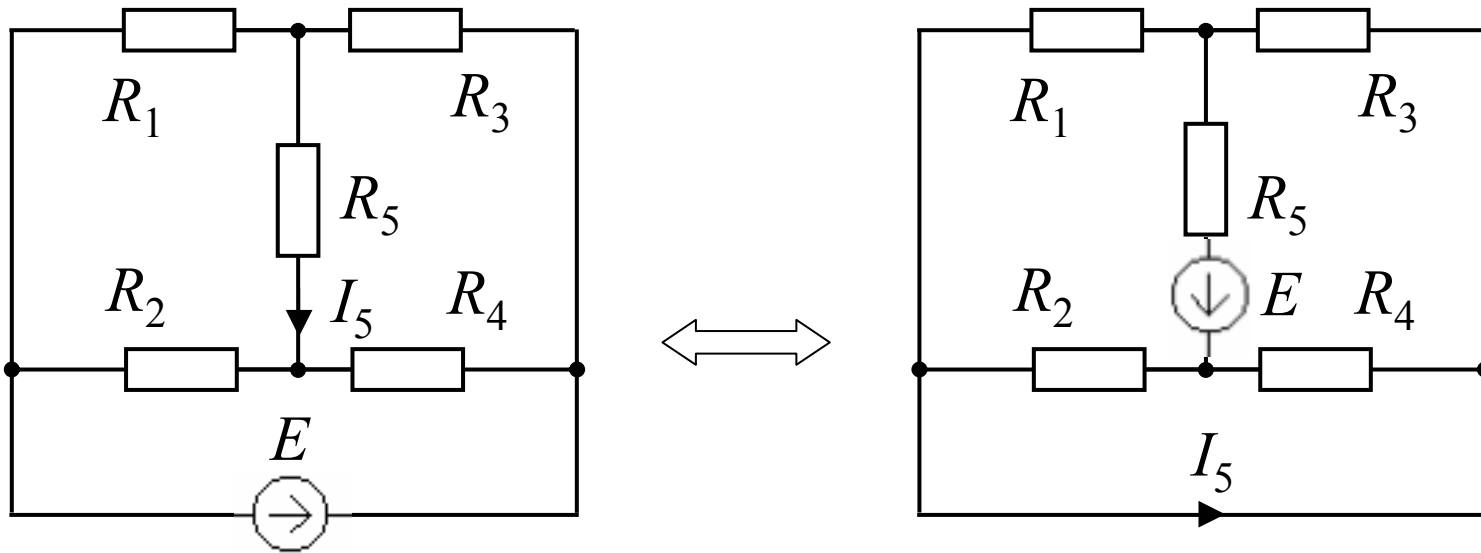

## Tương hỗ (8)

- [Z]:  $Z_{12} = Z_{21}$
- [Y]:  $Y_{12} = Y_{21}$
- [H]:  $H_{12} = -H_{21}$
- [G]:  $G_{12} = -G_{21}$
- [A]:  $\det(A) = 1$
- [B]:  $\det(B) = 1$

## Mạng hai cửa

- Các bộ thông số
- Quan hệ giữa các bộ thông số
- Phân tích mạch có mạng hai cửa
- Kết nối các mạng hai cửa
- Mạng  $T$  &  $\Pi$
- Tương hỗ
- **Tổng trở vào & hoà hợp tải**
- Hàm truyền đạt



# Tổng trở vào & hoà hợp tải (1)

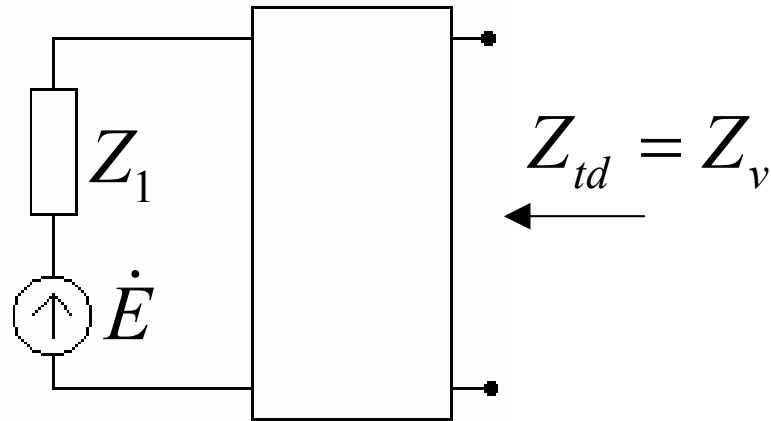
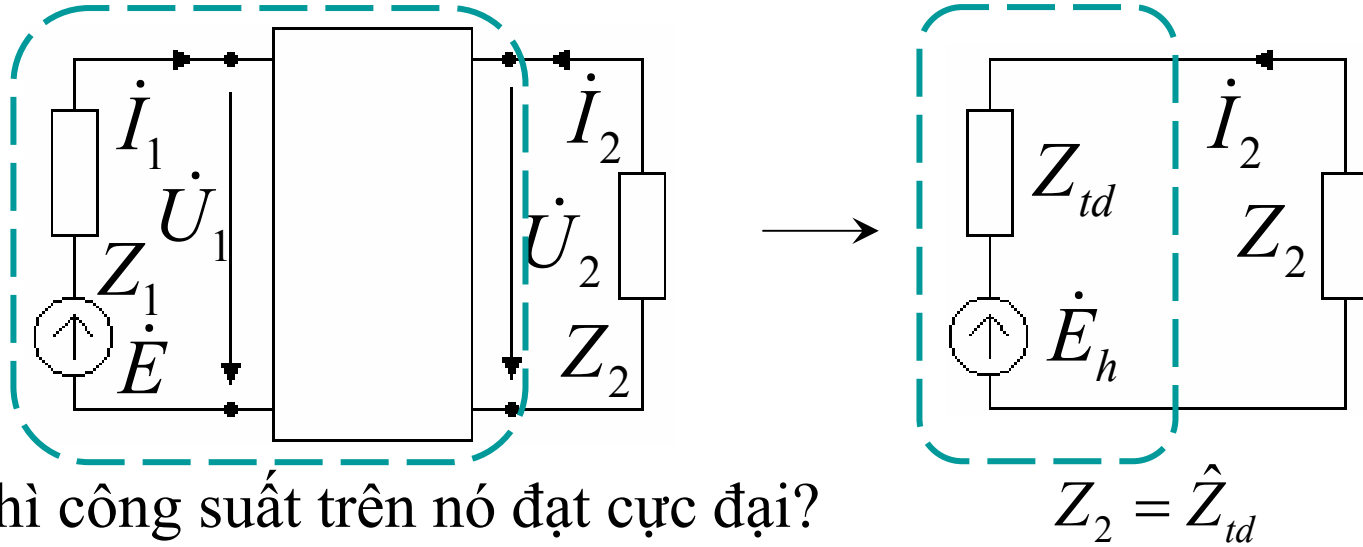

Mạng hai cửa



# Tổng trở vào & hoà hợp tải (2)

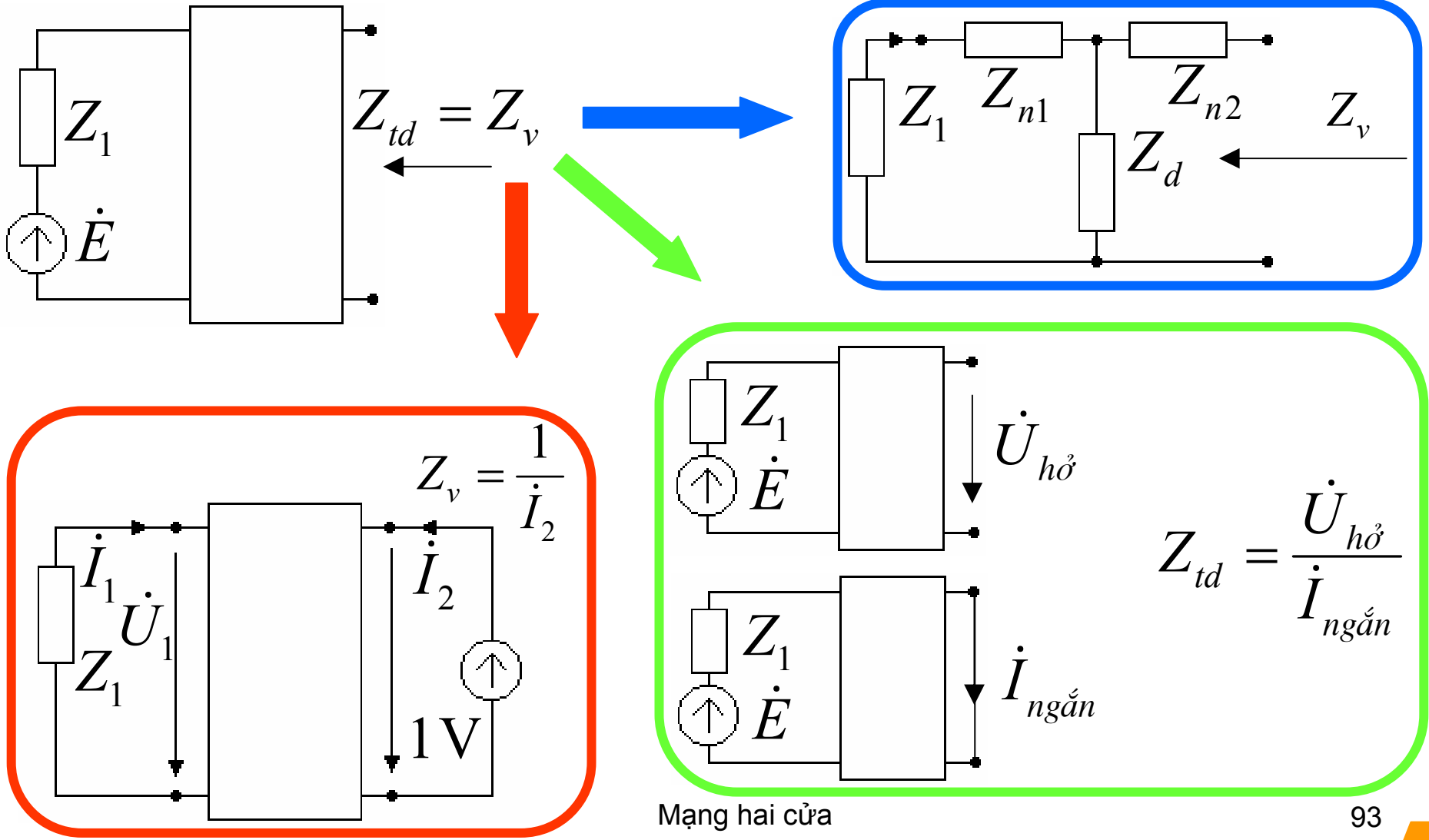



## Tổng trở vào & hoà hợp tải (3)

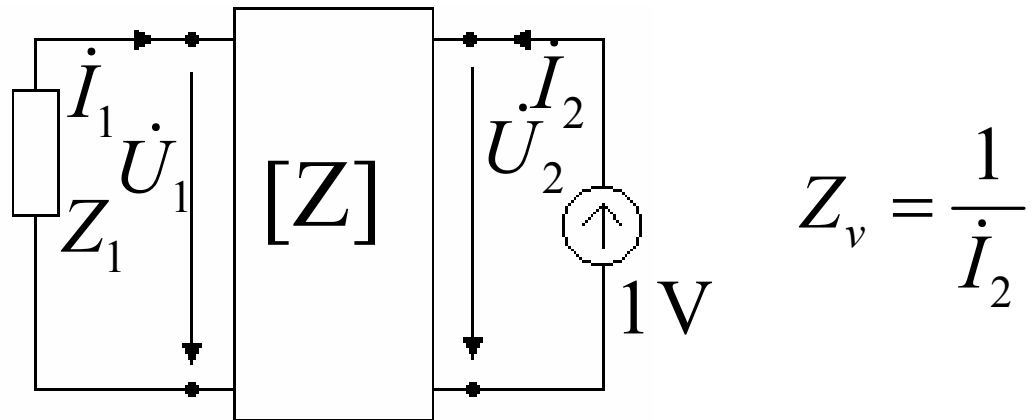

$$\left\{ \begin{array}{l} Z_1 \dot{I}_1 + \dot{U}_1 = 0 \\ \dot{U}_2 = 1 \\ \dot{U}_1 = Z_{11} \dot{I}_1 + Z_{12} \dot{I}_2 \\ \dot{U}_2 = Z_{21} \dot{I}_1 + Z_{22} \dot{I}_2 \end{array} \right. \rightarrow \dot{I}_2 \rightarrow Z_v = \frac{1}{\dot{I}_2}$$

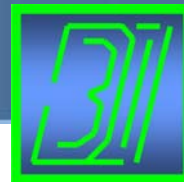

# Tổng trở vào & hoà hợp tải (4)

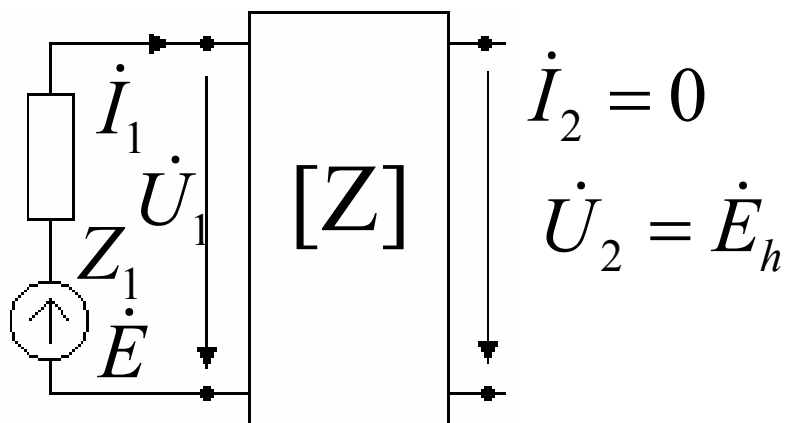
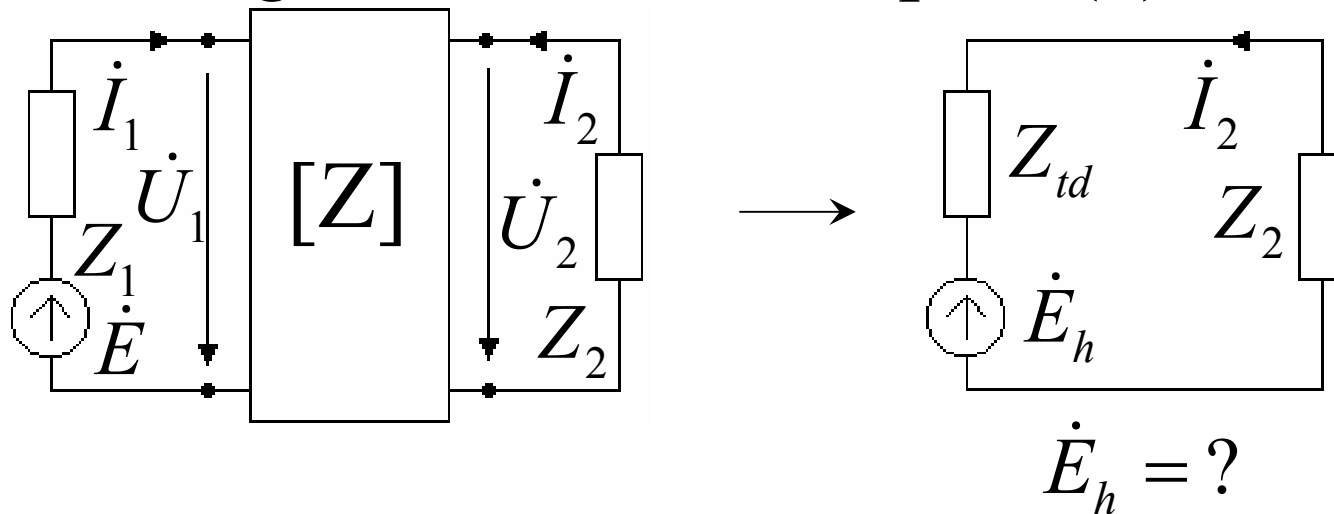

$$\left\{ \begin{array}{l} Z_1 \dot{I}_1 + \dot{U}_1 = \dot{E} \\ \dot{I}_2 = 0 \\ \dot{U}_1 = Z_{11} \dot{I}_1 + Z_{12} \dot{I}_2 \\ \dot{U}_2 = Z_{21} \dot{I}_1 + Z_{22} \dot{I}_2 \end{array} \right. \rightarrow \dot{U}_2$$



VD

# Tổng trở vào & hoà hợp tải (5)

$$\mathbf{Z} = \begin{bmatrix} 30 & 20 \\ 20 & 50 \end{bmatrix}; \dot{E} = 220 \text{ V}; Z_1 = 15 + j25 \Omega$$

Tìm  $Z_2$  để  $P_{Z_2}$  cực đại.

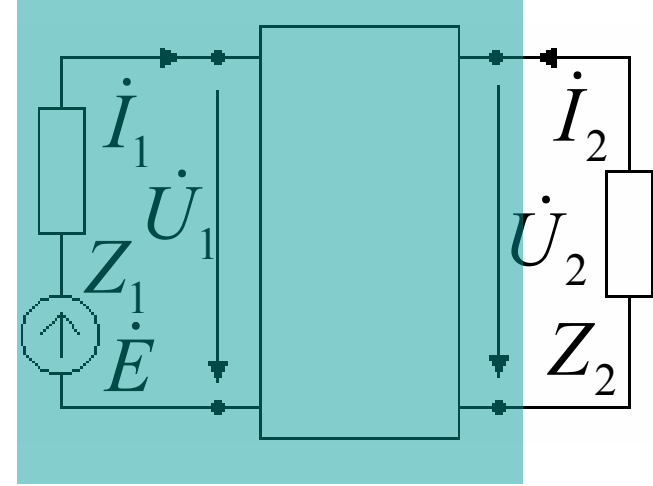

$$Z_2 = \hat{Z}_{td}$$

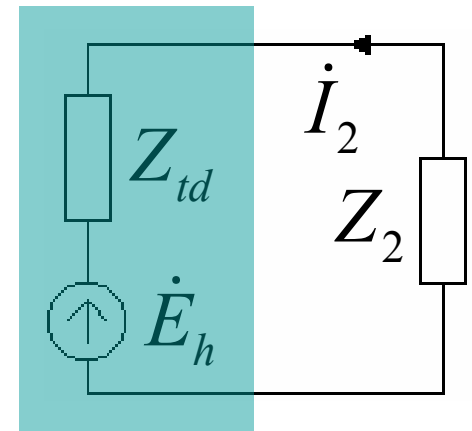





# VD Tổng trở vào & hoà hợp tải (6)

$$\mathbf{Z} = \begin{bmatrix} 30 & 20 \\ 20 & 50 \end{bmatrix}; \dot{E} = 220 \text{ V}; Z_1 = 15 + j25 \Omega$$

Tìm  $Z_2$  để  $P_{Z_2}$  cực đại.

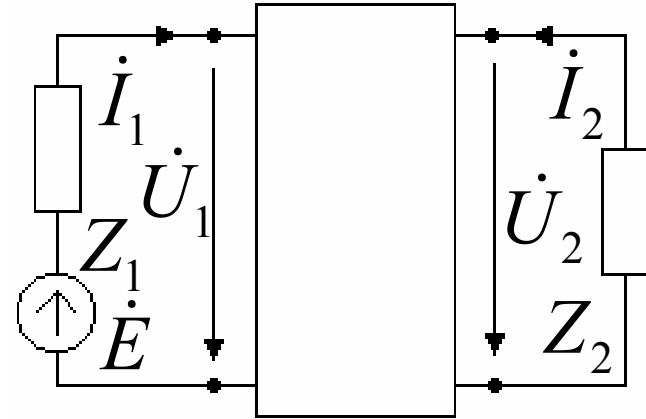

(Cách 1)  $Z_{td} = \frac{1}{\dot{I}_2}$

$$\begin{cases} (15 + j25)\dot{I}_1 + \dot{U}_1 = 0 \\ \dot{U}_2 = 1 \\ \dot{U}_1 = 30\dot{I}_1 + 20\dot{I}_2 \\ \dot{U}_2 = 20\dot{I}_1 + 50\dot{I}_2 \end{cases}$$

→  $\dot{I}_2 = 0,023 - j0,002 \text{ A}$   
 →  $Z_{td} = 43,15 + j3,75 \Omega$   
 →  $Z_2 = 43,15 - j3,75 \Omega$

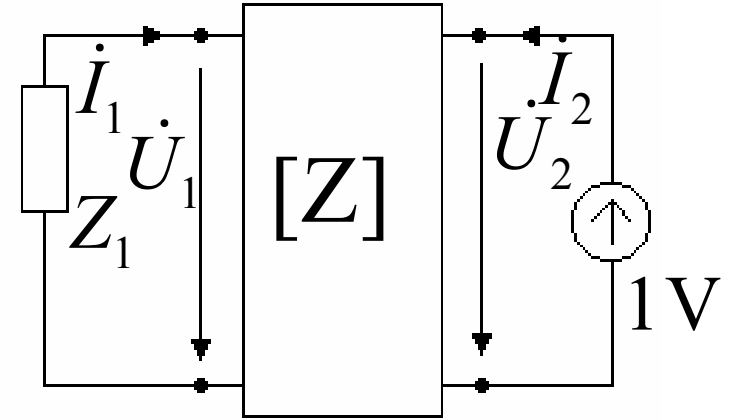



**VD**

# Tổng trở vào & hoà hợp tải (7)

$$\mathbf{Z} = \begin{bmatrix} 30 & 20 \\ 20 & 50 \end{bmatrix}; \dot{E} = 220 \text{ V}; Z_1 = 15 + j25 \Omega$$

Tìm  $Z_2$  để  $P_{Z_2}$  cực đại.

Cách 2: 
$$Z_{td} = \frac{\dot{U}_{hở}}{\dot{I}_{ngắn}}$$

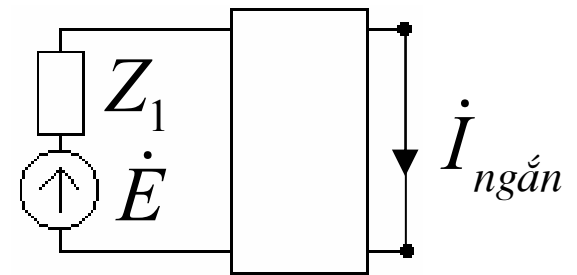
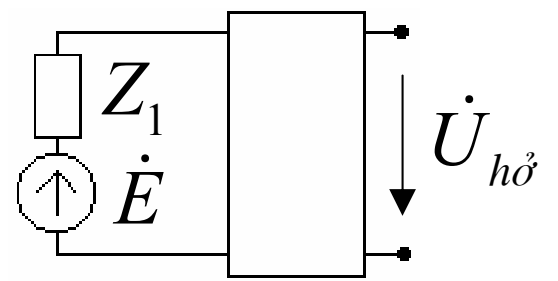
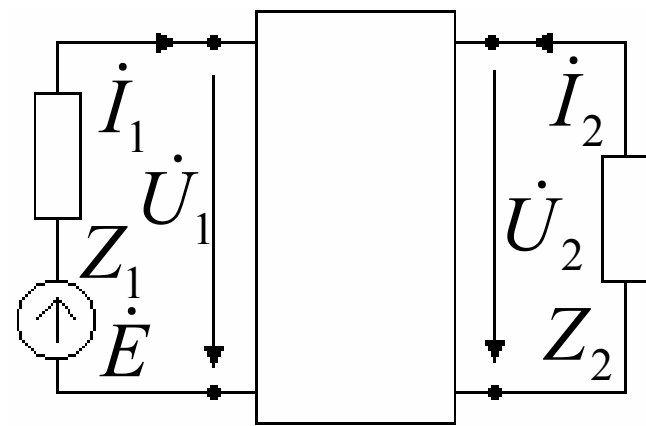



**VD**

## Tổng trở vào & hoà hợp tải (8)

$$\mathbf{Z} = \begin{bmatrix} 30 & 20 \\ 20 & 50 \end{bmatrix}; \dot{E} = 220 \text{ V}; Z_1 = 15 + j25 \Omega$$

Tìm  $Z_2$  để  $P_{Z_2}$  cực đại.

Cách 2: 
$$Z_{td} = \frac{\dot{U}_{hở}}{\dot{I}_{ngắn}}$$

$$\begin{cases} (15 + j25)\dot{I}_1 + \dot{U}_1 = \dot{E} = 220 \\ \dot{I}_2 = 0 \\ \dot{U}_1 = 30\dot{I}_1 + 20\dot{I}_2 \\ \dot{U}_2 = 20\dot{I}_1 + 50\dot{I}_2 \end{cases}$$

$$\rightarrow \dot{U}_2 = 74,72 - j41,51 \text{ V} = \dot{U}_{hở}$$

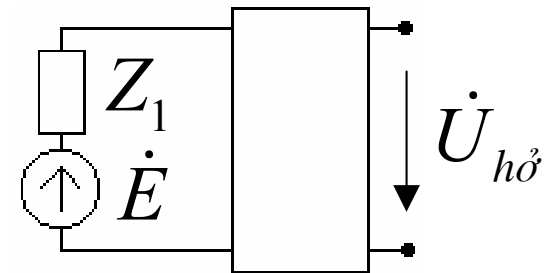
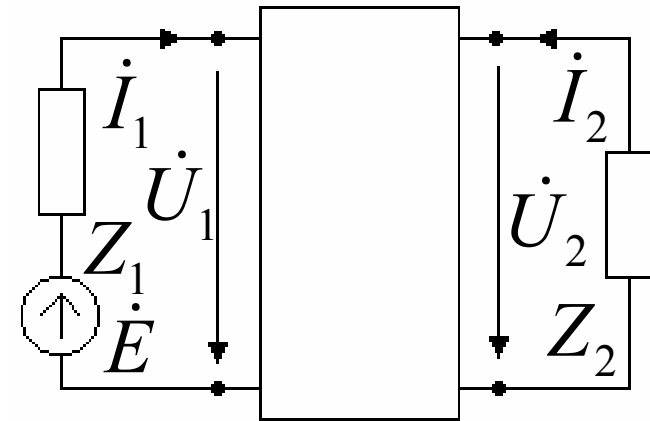

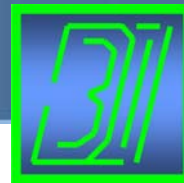

**VD**

# Tổng trở vào & hoà hợp tải (9)

$$\mathbf{Z} = \begin{bmatrix} 30 & 20 \\ 20 & 50 \end{bmatrix}; \dot{E} = 220 \text{ V}; Z_1 = 15 + j25 \Omega$$

Tìm  $Z_2$  để  $P_{Z_2}$  cực đại.

Cách 2: 
$$Z_{td} = \frac{\dot{U}_{hở}}{\dot{I}_{ngắn}}$$

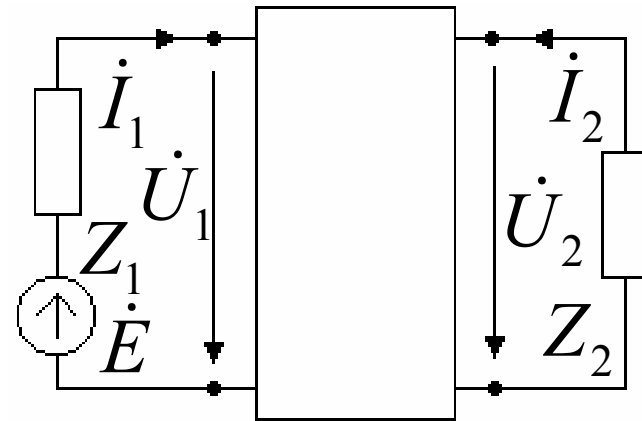

$$\begin{cases} (15 + j25)\dot{I}_1 + \dot{U}_1 = \dot{E} = 220 \\ \dot{U}_2 = 0 \\ \dot{U}_1 = 30\dot{I}_1 + 20\dot{I}_2 \\ \dot{U}_2 = 20\dot{I}_1 + 50\dot{I}_2 \end{cases}$$

$$\rightarrow \dot{I}_2 = -1,63 + j1,10 \text{ A} = -\dot{I}_{ngắn}$$

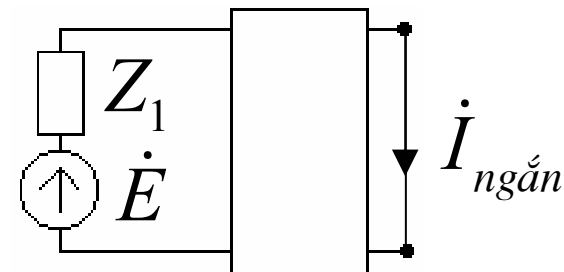



**VD**

# Tổng trở vào & hoà hợp tải (10)

$$\mathbf{Z} = \begin{bmatrix} 30 & 20 \\ 20 & 50 \end{bmatrix}; \dot{E} = 220 \text{ V}; Z_1 = 15 + j25 \Omega$$

Tìm  $Z_2$  để  $P_{Z_2}$  cực đại.

Cách 2:

$$Z_{td} = \frac{\dot{U}_{hở}}{\dot{I}_{ngắn}}$$

$$\dot{U}_{hở} = 74,72 - j41,51 \text{ V}$$

$$\dot{I}_{ngắn} = 1,63 - j1,10 \text{ A}$$

$$\rightarrow Z_{td} = \frac{74,72 - j41,51}{1,63 - j1,10} = 43,31 + j3,77 \Omega$$

$$\rightarrow \boxed{Z_2 = 43,31 - j3,77 \Omega}$$

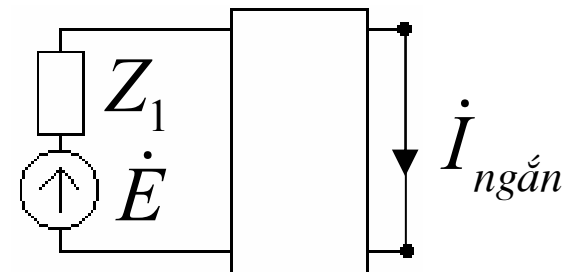
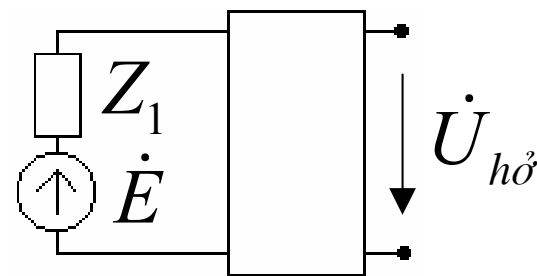
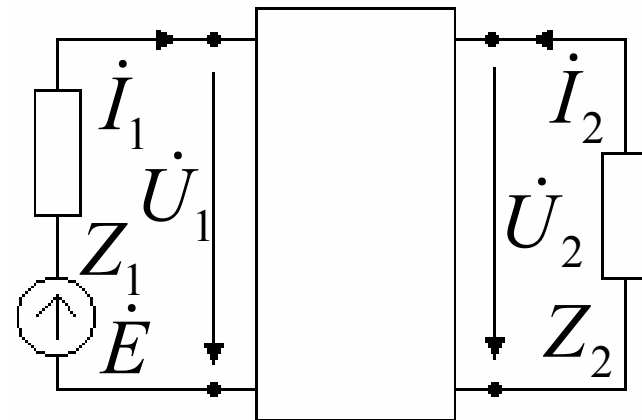



# Tổng trở vào & hoà hợp tải (11)

$$\begin{cases} \dot{U}_1 = A_{11}\dot{U}_2 + A_{12}\dot{I}_2 \\ \dot{I}_1 = A_{21}\dot{U}_2 + A_{22}\dot{I}_2 \end{cases}$$

$$\left. \begin{aligned} Z_{1v} &= \frac{\dot{U}_1}{\dot{I}_1} = \frac{A_{11}\dot{U}_2 + A_{12}\dot{I}_2}{A_{21}\dot{U}_2 + A_{22}\dot{I}_2} \\ \dot{U}_2 &= Z_2\dot{I}_2 \end{aligned} \right\}$$

$$\rightarrow Z_{1v} = \frac{A_{11}Z_2 + A_{12}}{A_{21}Z_2 + A_{22}}$$

$$\left. \begin{aligned} Z_{2v} &= \frac{\dot{U}_2}{-\dot{I}_2} = \frac{-A_{22}\dot{U}_1 + A_{12}\dot{I}_1}{-A_{21}\dot{U}_1 + A_{11}\dot{I}_1} \\ \dot{U}_1 &= -Z_1\dot{I}_1 \end{aligned} \right\}$$

$$\rightarrow Z_{2v} = \frac{A_{22}Z_1 + A_{12}}{A_{21}Z_1 + A_{11}}$$

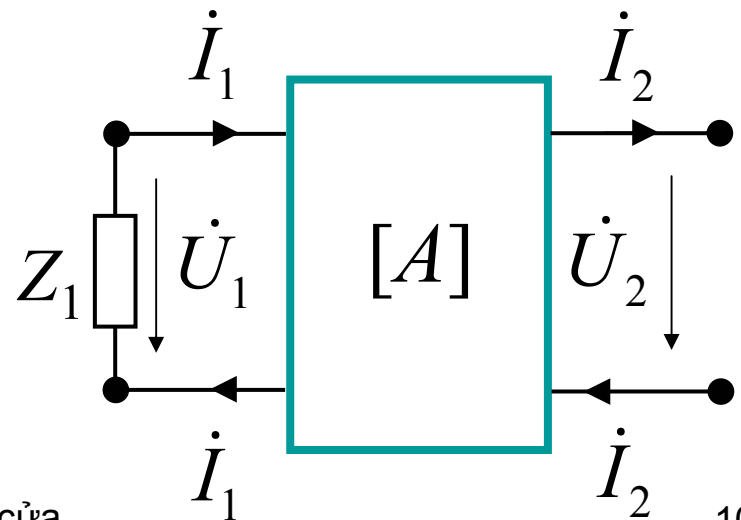
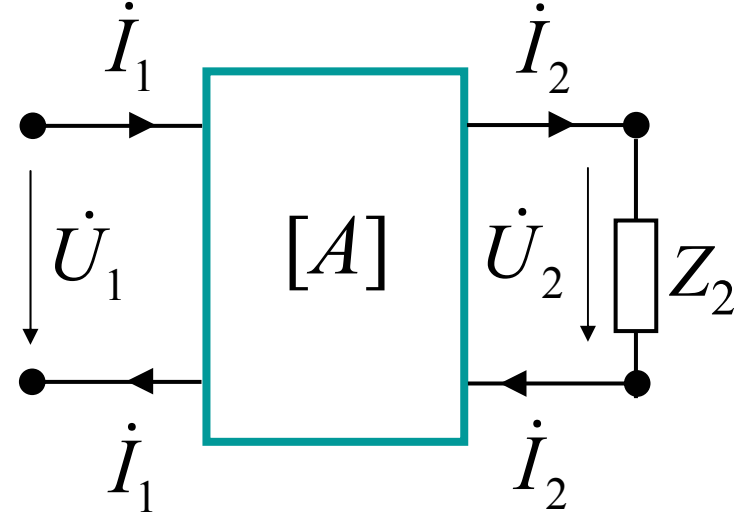

## Tổng trở vào & hoà hợp tải (12)

$$\left. \begin{aligned} Z_{1v} &= \frac{A_{11}Z_2 + A_{12}}{A_{21}Z_2 + A_{22}} \\ Z_2 &= 0 \text{ (ngắn mạch đầu ra)} \end{aligned} \right\} \rightarrow Z_{1\text{ngắn mạch}} = \frac{A_{12}}{A_{22}}$$

$$\left. \begin{aligned} Z_{1v} &= \frac{A_{11}Z_2 + A_{12}}{A_{21}Z_2 + A_{22}} \\ Z_2 &\rightarrow \infty \text{ (hở mạch đầu ra)} \end{aligned} \right\} \rightarrow Z_{1\text{hở mạch}} = \frac{A_{11}}{A_{21}}$$

$$\left. \begin{aligned} Z_{2v} &= \frac{A_{22}Z_1 + A_{12}}{A_{21}Z_1 + A_{11}} \\ Z_1 &= 0 \text{ (ngắn mạch đầu vào)} \end{aligned} \right\} \rightarrow Z_{2\text{ngắn mạch}} = \frac{A_{12}}{A_{11}}$$

$$\left. \begin{aligned} Z_{2v} &= \frac{A_{22}Z_1 + A_{12}}{A_{21}Z_1 + A_{11}} \\ Z_1 &\rightarrow \infty \text{ (hở mạch đầu vào)} \end{aligned} \right\} \rightarrow Z_{2\text{hở mạch}} = \frac{A_{22}}{A_{21}}$$

# Tổng trở vào & hoà hợp tải (13)

$$\left. \begin{aligned}
 Z_{1\text{ngắn mạch}} &= \frac{A_{12}}{A_{22}} = Z_{1\text{ng}} \\
 Z_{1\text{hở mạch}} &= \frac{A_{11}}{A_{21}} = Z_{1\text{h}} \\
 Z_{2\text{ngắn mạch}} &= \frac{A_{12}}{A_{11}} = Z_{2\text{ng}} \\
 Z_{2\text{hở mạch}} &= \frac{A_{22}}{A_{21}} = Z_{2\text{h}}
 \end{aligned} \right\} \rightarrow \left\{ \begin{aligned}
 A_{11} &= \sqrt{\frac{Z_{1\text{ng}} Z_{1\text{h}}}{Z_{2\text{ng}} (Z_{1\text{h}} - Z_{1\text{ng}})}} \\
 A_{12} &= A_{11} Z_{2\text{ng}} \\
 A_{21} &= \frac{A_{11}}{Z_{1\text{h}}} \\
 A_{22} &= \frac{A_{12}}{Z_{1\text{ng}}}
 \end{aligned} \right.$$



# Tổng trở vào & hoà hợp tải (14)

**VD** Tính bộ số **A**.

$$A_{11} = \left. \frac{\dot{U}_1}{\dot{U}_2} \right|_{i_2=0}$$

$$A_{11} = \sqrt{\frac{Z_{1ng} Z_{1h}}{Z_{2ng} (Z_{1h} - Z_{1ng})}}$$

$$A_{12} = A_{11} Z_{2ng}$$

$$A_{21} = \frac{A_{11}}{Z_{1h}}$$

$$A_{22} = \frac{A_{12}}{Z_{1ng}}$$

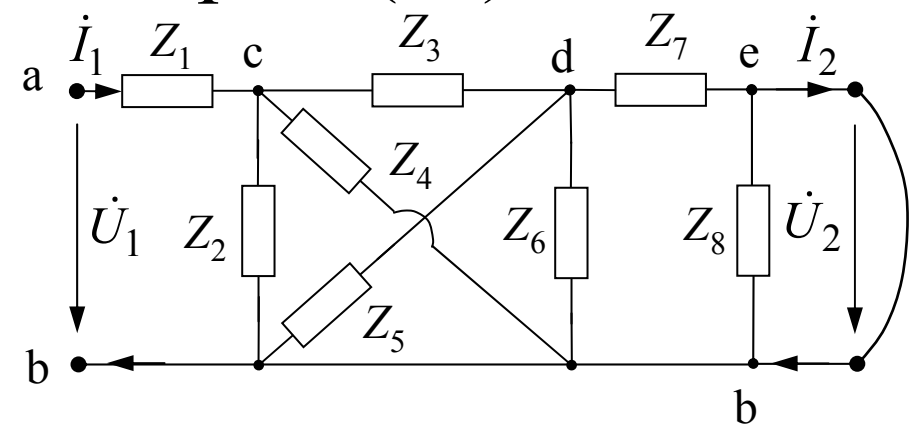

$Z_{1ng} = ?$

$$Z_{1ng} = Z_{ab} = \{ [(Z_7 // Z_6 // Z_5) + Z_3] // Z_4 // Z_2 \} + Z_1$$



# Tổng trở vào & hoà hợp tải (15)

**VD** Tính bộ số **A**.

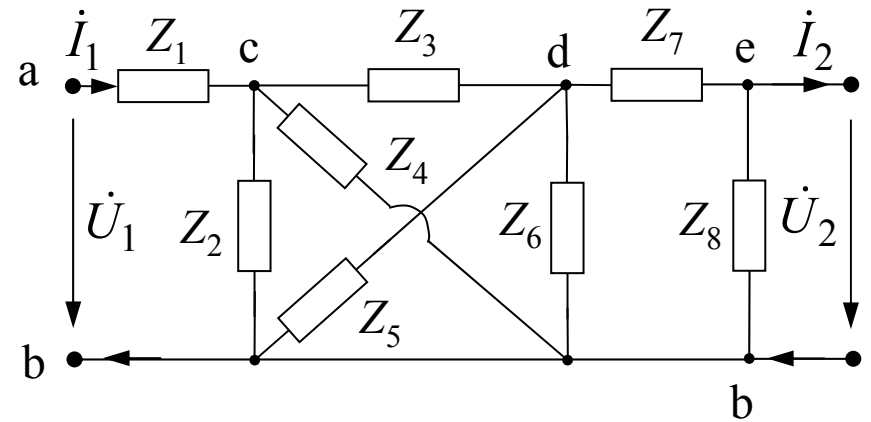

$Z_{1h} = ?$

$$A_{11} = \sqrt{\frac{Z_{1ng} Z_{1h}}{Z_{2ng} (Z_{1h} - Z_{1ng})}}$$

$$A_{12} = A_{11} Z_{2ng}$$

$$A_{21} = \frac{A_{11}}{Z_{1h}}$$

$$A_{22} = \frac{A_{12}}{Z_{1ng}}$$

$$Z_{1h} = Z_{ab} = [ \{ [(Z_7 + Z_8) // Z_6 // Z_5] + Z_3 \} // Z_4 // Z_2 ] + Z_1$$



# Tổng trở vào & hoà hợp tải (16)

**VD** Tính bộ số **A**.

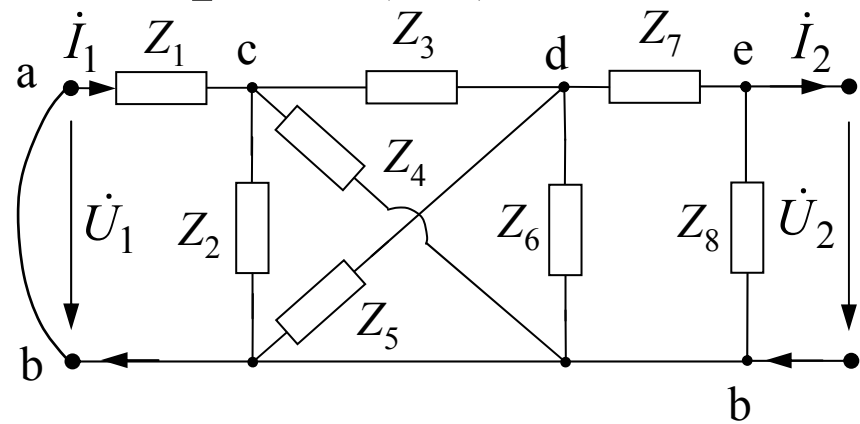

$$Z_{2ng} = ?$$

$$A_{11} = \sqrt{\frac{Z_{1ng} Z_{1h}}{Z_{2ng} (Z_{1h} - Z_{1ng})}}$$

$$A_{12} = A_{11} Z_{2ng}$$

$$A_{21} = \frac{A_{11}}{Z_{1h}}$$

$$A_{22} = \frac{A_{12}}{Z_{1ng}}$$

$$Z_{2ng} = Z_{eb} = [ \{ [(Z_1 // Z_2 // Z_4) + Z_3] // Z_5 // Z_6 \} + Z_7 ] // Z_8$$

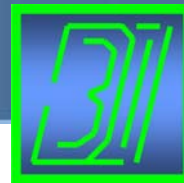

# Tổng trở vào & hoà hợp tải (17)

**VD** Tính bộ số **A**.

$$\left. \begin{matrix} Z_{1ng} \\ Z_{1h} \\ Z_{2ng} \end{matrix} \right\} \rightarrow \begin{cases} A_{11} = \sqrt{\frac{Z_{1ng}Z_{1h}}{Z_{2ng}(Z_{1h} - Z_{1ng})}} \\ A_{12} = A_{11}Z_{2ng} \\ A_{21} = \frac{A_{11}}{Z_{1h}} \\ A_{22} = \frac{A_{12}}{Z_{1ng}} \end{cases}$$

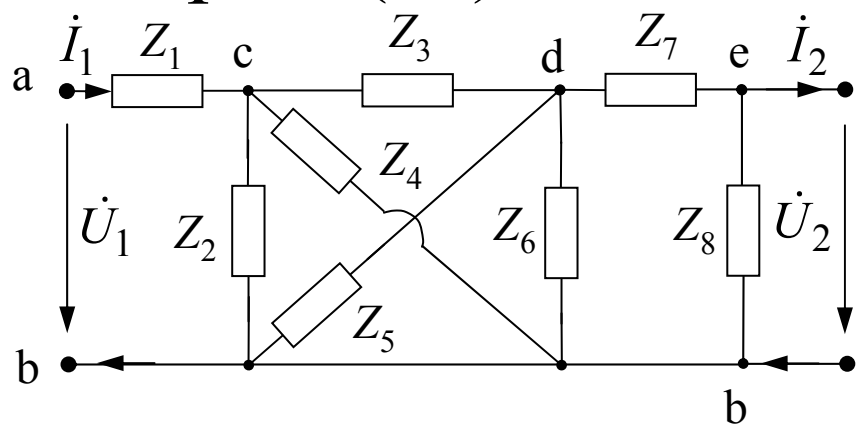

# Tổng trở vào & hoà hợp tải (18)

$$\left. \begin{aligned}
 A_{11} &= \sqrt{\frac{Z_{1ng} Z_{1h}}{Z_{2ng} (Z_{1h} - Z_{1ng})}} \\
 A_{12} &= A_{11} Z_{2ng} \\
 A_{21} &= \frac{A_{11}}{Z_{1h}} \\
 A_{22} &= \frac{A_{12}}{Z_{1ng}}
 \end{aligned} \right\} \rightarrow \boxed{|\mathbf{A}| = A_{11} A_{22} - A_{12} A_{21} = 1}$$

## Mạng hai cửa

- Các bộ thông số
- Quan hệ giữa các bộ thông số
- Phân tích mạch có mạng hai cửa
- Kết nối các mạng hai cửa
- Mạng  $T$  &  $\Pi$
- Tương hỗ
- Tổng trở vào & hoà hợp tải
- **Hàm truyền đạt**

## Hàm truyền đạt (1)

- Hàm truyền đạt áp: 
$$K_u = \frac{\dot{U}_2}{\dot{U}_1}$$
- Hàm truyền đạt dòng: 
$$K_i = \frac{\dot{I}_2}{\dot{I}_1}$$
- Hàm truyền đạt áp dòng: 
$$K_{ui} = \frac{\dot{U}_2}{\dot{I}_1}$$



**VD1**

Hàm truyền đạt (2)

$$Z = \begin{bmatrix} 30 & 20 \\ 20 & 50 \end{bmatrix}; \dot{E} = 220 \text{ V}$$

$$Z_t = 15 + j25 \Omega$$

Tính  $K_u, K_i, K_{ui}$ .

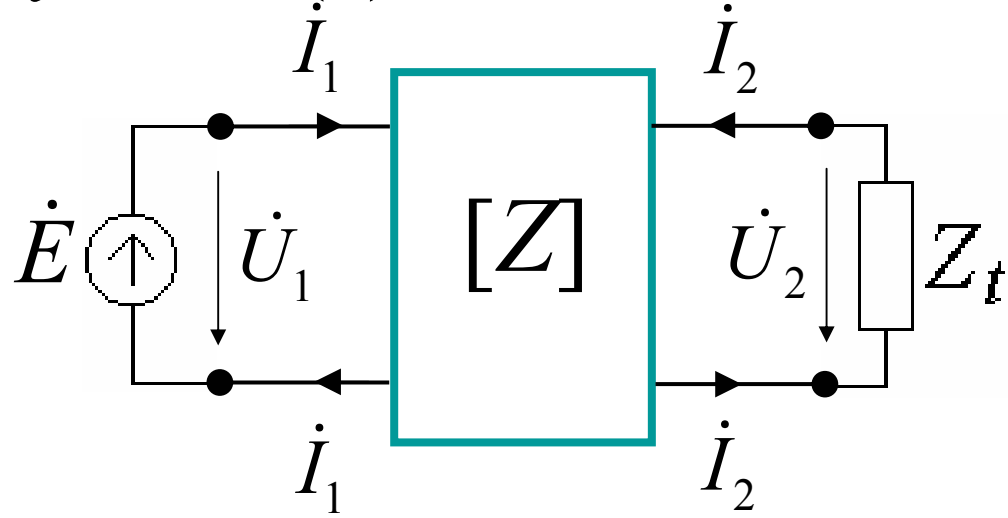

$$\left\{ \begin{array}{l} \dot{U}_1 = Z_{11}\dot{I}_1 + Z_{12}\dot{I}_2 \\ \dot{U}_2 = Z_{21}\dot{I}_1 + Z_{22}\dot{I}_2 \\ \dot{U}_1 = \dot{E} \\ \dot{U}_2 = -Z_t\dot{I}_2 \end{array} \right.$$

$$\rightarrow \left\{ \begin{array}{l} \dot{E} = Z_{11}\dot{I}_1 + Z_{12}\dot{I}_2 \\ -Z_t\dot{I}_2 = Z_{21}\dot{I}_1 + Z_{22}\dot{I}_2 \end{array} \right.$$

$$\rightarrow \left\{ \begin{array}{l} \dot{I}_1 = \frac{Z_{22} + Z_t}{Z_{11}Z_{22} - Z_{12}Z_{21} + Z_{11}Z_t} \dot{E} \\ \dot{I}_2 = \frac{-Z_{21}}{Z_{11}Z_{22} - Z_{12}Z_{21} + Z_{11}Z_t} \dot{E} \end{array} \right.$$





**VD1**

Hàm truyền đạt (3)

$$Z = \begin{bmatrix} 30 & 20 \\ 20 & 50 \end{bmatrix}; \dot{E} = 220 \text{ V}$$

$$Z_t = 15 + j25 \Omega$$

Tính  $K_u, K_i, K_{ui}$ .

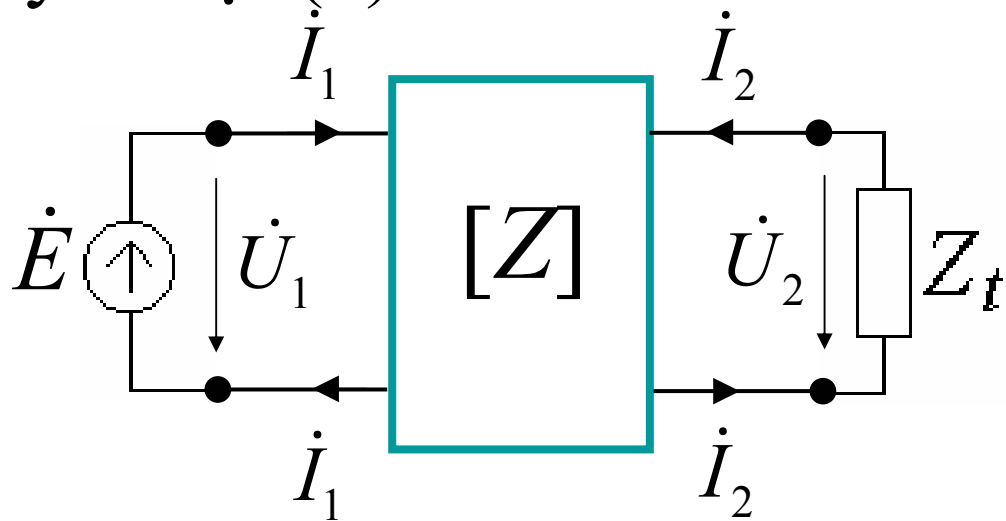

$$\dot{I}_1 = \frac{Z_{22} + Z_t}{Z_{11}Z_{22} - Z_{12}Z_{21} + Z_{11}Z_t} \dot{E}$$

$$\dot{I}_2 = \frac{-Z_{21}}{Z_{11}Z_{22} - Z_{12}Z_{21} + Z_{11}Z_t} \dot{E}$$

$$\left. \begin{array}{l} \dot{U}_2 = -Z_t \dot{I}_2 \end{array} \right\} \rightarrow \dot{U}_2 = \frac{Z_{21}Z_t}{Z_{11}Z_{22} - Z_{12}Z_{21} + Z_{11}Z_t} \dot{E}$$

$$\rightarrow K_u = \frac{\dot{U}_2}{\dot{U}_1} = \frac{Z_{21}Z_t}{Z_{11}Z_{22} - Z_{12}Z_{21} + Z_{11}Z_t} = \boxed{0,28 + j0,19}$$



**VD1**

Hàm truyền đạt (4)

$$Z = \begin{bmatrix} 30 & 20 \\ 20 & 50 \end{bmatrix}; \dot{E} = 220 \text{ V}$$

$$Z_t = 15 + j25 \Omega$$

Tính  $K_u, K_i, K_{ui}$ .

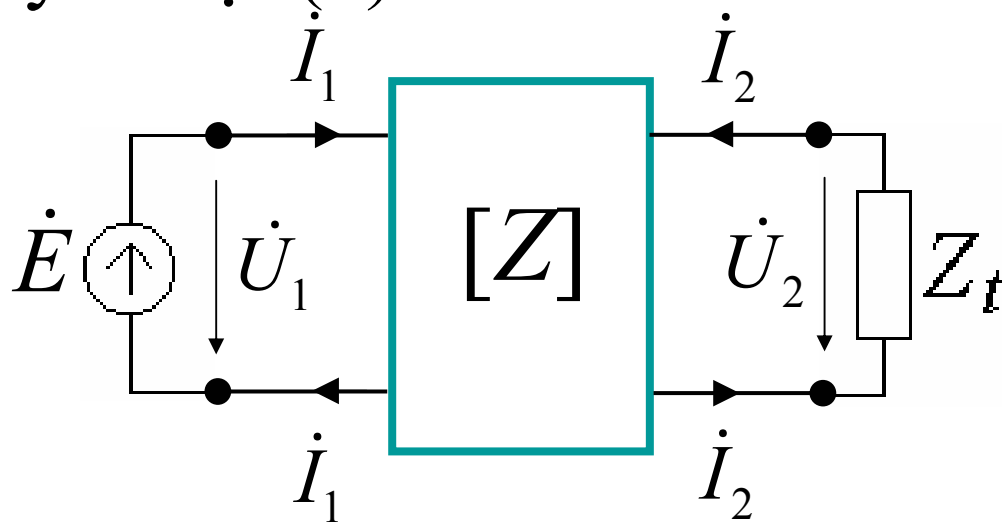

$$\dot{I}_1 = \frac{Z_{22} + Z_t}{Z_{11}Z_{22} - Z_{12}Z_{21} + Z_{11}Z_t} \dot{E}$$

$$\dot{I}_2 = \frac{-Z_{21}}{Z_{11}Z_{22} - Z_{12}Z_{21} + Z_{11}Z_t} \dot{E}$$

$$K_i = \frac{\dot{I}_2}{\dot{I}_1}$$

$$\rightarrow K_i = \frac{-Z_{21}}{Z_{22} + Z_t} = \boxed{-0,27 + j0,10}$$

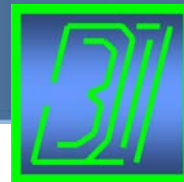

**VD1**

Hàm truyền đạt (5)

$$Z = \begin{bmatrix} 30 & 20 \\ 20 & 50 \end{bmatrix}; \dot{E} = 220 \text{ V}$$

$$Z_t = 15 + j25 \Omega$$

Tính  $K_u, K_i, K_{ui}$ .

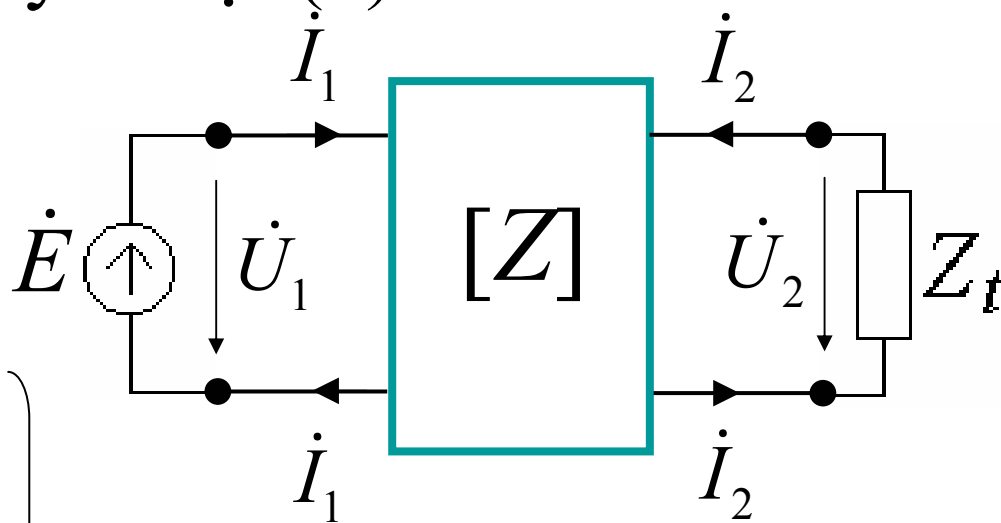

$$\dot{I}_1 = \frac{Z_{22} + Z_t}{Z_{11}Z_{22} - Z_{12}Z_{21} + Z_{11}Z_t} \dot{E}$$

$$\dot{U}_2 = \frac{Z_{21}Z_t}{Z_{11}Z_{22} - Z_{12}Z_{21} + Z_{11}Z_t} \dot{E}$$

$$K_{ui} = \frac{\dot{U}_2}{\dot{I}_1}$$

$$\rightarrow K_{ui} = \frac{Z_{21}Z_t}{Z_{22} + Z_t}$$

$$= \boxed{6,60 + j5,15 \Omega}$$



**VD2**

Hàm truyền đạt (6)

$$\dot{E} = 380 \text{ V}; Z_t = 15 + j25 \Omega;$$

$$K_u = 0,28 + j0,19; \text{ Tính } U_2.$$

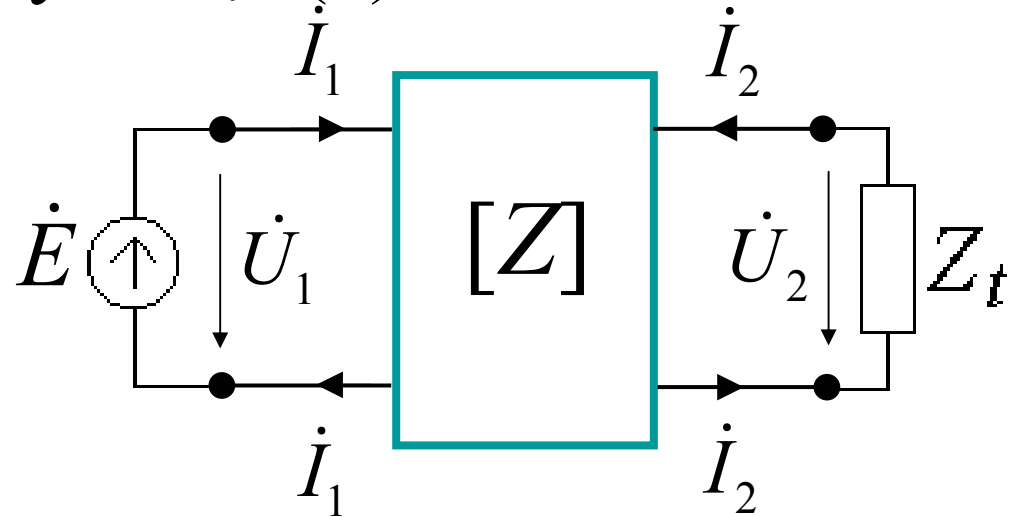

$$\left. \begin{aligned} K_u &= \frac{\dot{U}_2}{\dot{U}_1} \\ \dot{U}_1 &= \dot{E} \end{aligned} \right\} \rightarrow \dot{U}_2 = K_u \dot{E} = (0,28 + j0,19)380$$

$$= 107,7 + j70,5 \text{ V}$$

$$\rightarrow \boxed{U_2 = 128,7 \text{ V}}$$

## Mạng hai cửa

- Các bộ thông số
- Quan hệ giữa các bộ thông số
- Phân tích mạch có mạng hai cửa
- Kết nối các mạng hai cửa
- Mạng  $T$  &  $\Pi$
- Tương hỗ
- Tổng trở vào & hoà hợp tải
- Hàm truyền đạt