



Basics of Circuit Breakers

 **Allen-Bradley**

Additional information for the
practical use of circuit breakers

 **Rockwell
Automation**

Bringing Together Leading Brands in Industrial Automation

Content:

1.	Design, function and types of circuit breakers	1.1
1.1.	Summary	1.1
1.2.	Types of switches	1.2
1.2.1.	Manual motor starter and protector or circuit breaker with motor protective characteristics	1.2
1.2.2.	Circuit breaker	1.2
1.2.3.	Load break switch	1.6
1.2.4.	Disconnecter	1.6
1.2.5.	Main switch	1.7
1.2.6.	Emergency OFF-switch	1.8
1.2.7.	Summary: Circuit breaker as load break switch	1.8
1.3.	Design of a circuit breaker	1.9
1.3.1.	The current path of the circuit breaker	1.9
1.3.2.	Thermal overload release	1.10
1.3.3.	Electromagnetic overcurrent release	1.10
1.3.4.	Main contact system	1.12
1.3.5.	Auxiliary contacts	1.15
1.3.6.	Operating mechanism	1.15
1.4.	Functions of a circuit breaker	1.15
1.4.1.	Interrupting short-circuit current	1.16
1.4.2.	Reliable protection of motors	1.17
1.4.3.	Protection of leads and its optimum utilisation	1.18
1.4.4.	Protection of installations	1.19
1.4.5.	Integration in the control circuit	1.19
1.4.6.	Switching under normal service conditions	1.20
1.4.7.	Disconnecting function	1.20
1.4.8.	Locking out with a padlock	1.20
2.	Circuit breaker technology	2.1
2.1.	Summary	2.1
2.2.	Short-circuit current in supply systems	2.2
2.2.1.	Types of short-circuit	2.2
2.2.2.	The peak value of the short-circuit current	2.3
2.2.3.	Calculation of the short-circuit current close to the transformer	2.4

2.2.4.	Calculation of the short-circuit current in radial supply systems	2.7
2.2.5.	Dynamic stress on the connecting leads in the case of a short-circuit	2.16
2.3.	Short-circuit protection	2.18
2.3.1.	The principle of current limitation	2.18
2.3.2.	Breaking capacity	2.26
2.3.3.	Electrical life (durability) of circuit breakers	2.26
2.4.	Short-circuit co-ordination	2.28
2.4.1.	Definitions in accordance with the IEC 947-4-1	2.28
2.4.2.	Conclusions drawn from the definitions for the user	2.28
2.4.3.	Physical significance of the short-circuit co-ordination	2.30
2.4.4.	Requirements of a circuit breaker for a simple co-ordination of type "2"	2.33
3.	Fields of application of circuit breakers	3.1
3.1.	General procedure for the selection of correctly rated circuit breakers	3.1
3.2.	Circuit breakers for motor protection	3.2
3.2.1.	Protection of motors with direct-on-line starting	3.3
3.2.2.	Protection of motors with star-delta starting	3.4
3.2.3.	Protection during heavy-duty starting	3.8
3.2.4.	Circuit breaker with a motor protective device connected downstream	3.8
3.2.5.	Protection of motors in explosive environments	3.12
3.2.6.	Protection of motors with phase controlled starting (soft starter)	3.13
3.2.7.	Protection of frequency controlled motors (frequency converter)	3.14
3.3.	Circuit breakers for the protection of connecting leads and for group protection	3.16
3.3.1.	Protection of the connecting leads	3.16
3.3.2.	Group protection	3.16

3.4.	Circuit breakers for capacitors	3.17
3.5.	Circuit breakers for transformers	3.18
3.5.1.	Protection of transformer: primary side	3.18
3.5.2.	Protection of transformer: secondary side	3.18
3.6.	Circuit breakers for generators	3.18
3.7.	Circuit breakers for special supply frequencies	3.19
3.7.1.	Breaking capacity at frequencies below 50/60Hz	3.19
3.7.2.	Breaking capacity at frequencies above 50/60Hz	3.20
3.8.	Interruption of direct current	3.20
3.9.	Breaking capacity at higher supply voltages	3.21
3.10.	Selectivity (discrimination)	3.21
3.10.1.	Selectivity between circuit breakers	3.21
3.10.2.	Selectivity between circuit breaker and fuse	3.24
3.10.3.	Selectivity between fuses	3.25
4.	Arguments in favor of the circuit breaker	4.1
4.1.	Summary	4.1
4.2.	Comparison of the functions: circuit breaker / fuse	4.2
4.2.1.	Time-current characteristics	4.2
4.2.2.	Comparison of Joule-integrals	4.3
4.2.3.	Comparison of the ultimate tripping current	4.4
4.2.4.	Table of comparison	4.4
4.3.	Arguments in favour of the circuit breaker	4.6
4.3.1.	Prevention of accidents with the help of circuit breakers	4.6
4.3.2.	Ready to be switched on again without delay	4.8
4.3.3.	All pole interruption	4.9
4.3.4.	No ageing	4.9
4.3.5.	Reduction of the conductor cross-section	4.10
4.3.6.	Simplified planning of installations	4.14
4.3.7.	Reduction of costs of installations and optional costs	4.14

1. Design, function and types of circuit breakers

1.1. Summary

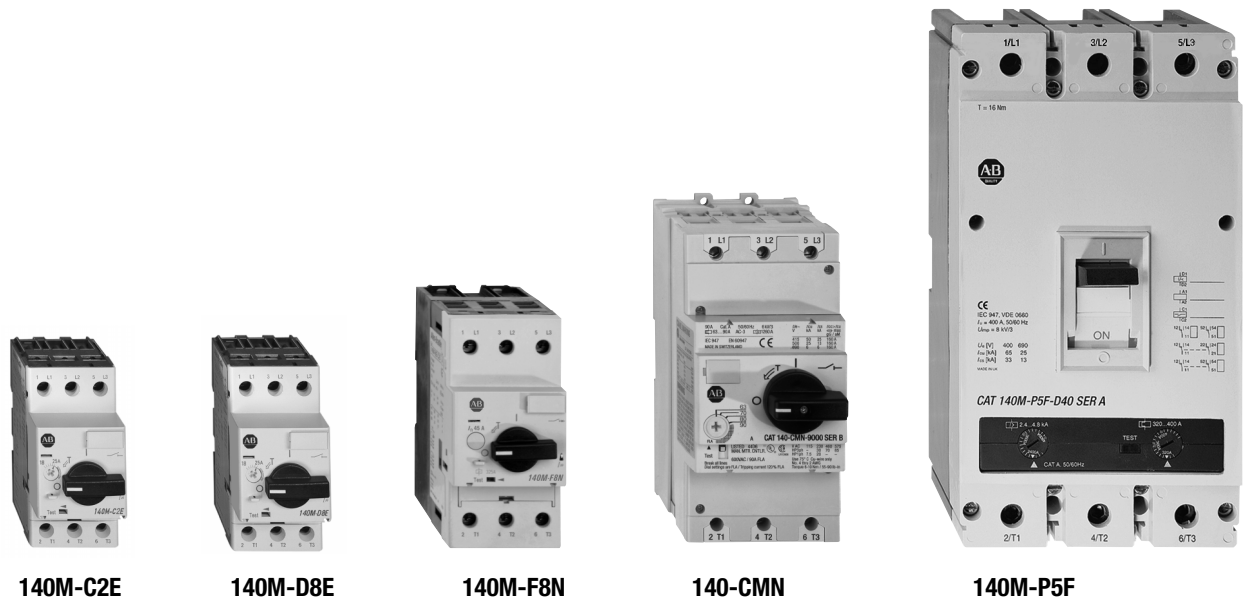

Fig. 1.1-1: Circuit breakers with motor protective characteristics from 0.1 A up to 400 A are included in the sales programme of Rockwell Automation•Allen-Bradley.

A circuit breaker, as we shall understand in the following text consists of a thermal overload release, an electromagnetic short-circuit release, a tripping (operating) mechanism, the main contact system and the auxiliary contacts. These are the most important functional blocks.

By integrating all these functional blocks in a single unit, it is possible to replace many individual components in an installation with one single device, viz. the circuit breaker. The combination of fuse, contactor and thermal overload relay will be replaced by the starter combination of circuit breaker and contactor.

One single device, the circuit breaker, fulfils the following functions :

- Short-circuit protection
- Motor protection
- Protection of connecting leads
- Protection of installations
- Signalisation of the switching state

- Tripping indication
- Switching under normal service conditions
- Remote switching
- Disconnecting
- Locking out with padlock (mandatory for main switch)

Hence, it can be used not only as a circuit breaker, but also as circuit breaker for motor protection, as load-break switch or as disconnector.

1.2. Types of switches

As a help for the selection of the right device, a short description follows :

- Manual motor starter and protector or circuit breaker with motor protective characteristic
- Circuit breaker
- Load-break switch
- Disconnecter
- Main switch
- Emergency OFF-switch

1.2.1. Manual motor starter and protector or circuit breaker with motor protective characteristic

The German expression "Motorschutzschalter" (there is no exact English equivalent to this expression) originally signified a manual motor starter with overload protection. This was used directly for the switching of smaller motors. In its original form, the short-circuit breaking capacity was rather limited. Today, however, under the expression "Motorschutzschalter" a circuit breaker with motor protective characteristic is also understood.

1.2.2. Circuit breaker

The circuit breaker is a mechanical switching device capable of protecting the circuit wiring, capable of making, carrying and breaking currents under normal circuit conditions and also making, carrying for a specified time and breaking currents under specified abnormal circuit conditions such as those of short-circuit (IEC 947-1).

Especially, the circuit breakers have the capability of interrupting short-circuit currents. For this reason, they are basically divided in categories depending on their breaking capacity, the type of construction and their capability of limiting the short-circuit current. Hence they can be classified under :

- Current-zero interrupting type of circuit breakers
- Current limiting type of circuit breakers

Depending on their over-current characteristics, the circuit breakers of the above two classes can again be divided into two groups :

- Circuit breakers for motor protection
- Circuit breakers for the protection of connecting circuits and installations.

1.2.2.1. The common abbreviations for the designations of circuit breakers

- **ACB:** Air Circuit Breaker. Large, open type circuit breakers for the protection of installations in the current range of approximately >100A (typical value).
- **CB:** Circuit Breaker
- **MCB:** Miniature Circuit Breaker. Small circuit breakers meant for the protection of the wiring, single or multiple pole, especially in building installations.
- **MCCB:** Moulded Case Circuit Breakers. In German language, understood as compact type of circuit breakers. A circuit breaker having a supporting housing of moulded insulating material forming an integral part of the circuit breaker (IEC 947-2).

Not to be confused with :

- **MCC:** Motor Control Centre. Low voltage, withdrawable type switchboards for motor branch circuits with main switch and door interlocking.
- **MCR:** Master Control Relay.

1.2.2.2. Current-zero interrupting type of circuit breaker

In the case of an alternating current, the arc is extinguished automatically at each current zero. This property is employed in the current-zero interrupting type of circuit breakers and the re-striking of the arc is prevented. The path of the arc is de-ionised by drawing away the heat-energy. In other words, the charged particles or ions are removed from the path across which the arc burned just before its extinction. A re-striking of the arc due to the recovery voltage across the contacts after the current zero is thus prevented.

Because of the fact that the current will be interrupted only after the natural current zero of the half cycle, these type of circuit breakers permit rather high let-through values. They are mostly utilised for the standard task of protecting the connecting wiring and installations. If the magnetic short-circuit tripping releases are provided with time-delay, they are especially suitable for use where selectivity or discrimination is called for. In this case, more than one circuit breakers, connected in series, are switched off one after another in a time delayed sequence.

1.2.2.3. Special features of the current limiting circuit breaker

In order to reduce the mechanical (due to electro-dynamic forces) and thermal stresses on the object to be protected, the current must be interrupted right during the initiation of the short-circuit, before the full prospective value can be attained (as for example to avoid the welding of the contactor contacts).

This is achieved by :

- Quick opening of the main contacts.
- Rapid build-up of a high arc-voltage (move the arc quickly away from the contact tips and guide it to the arc chamber).

The effects of the reduced let-through values are :

- Reduction of the electro-dynamic forces on the bus-bars (as for example increased spacing between supports).
- Reduction of thermal stresses. The welding of the contacts of contactors can be prevented. Over-dimensioning of the contactors can be avoided or at least kept within reasons. The result is reflected in the short-circuit co-ordination tables - compact starter combinations with components selected mostly on the basis of their rated currents.

The current limiting circuit breakers are used in a wide field of applications. It is no longer necessary to carry out complex calculations of the short-circuit current at each point of the network where a circuit breaker is installed. The subject of short-circuit co-ordination takes about as much planning effort as in the case of fuses.

The circuit breaker should be constructed in such a way that it can interrupt the short-circuit current under all possible situations without any problem whatsoever.

The features, which make the planning with circuit breakers as simple as that with fuses, are :

- High breaking capacity makes calculation of short-circuit current superfluous: in actual applications, the fault level (prospective short-circuit current) at the point where circuit breakers for motor branch circuits are installed lie mostly in the range of 1...20kA. If the breaking capacity of the circuit breaker is higher than this, no further calculation is necessary. The circuit breakers can be utilised in any point of the installation without calculations for its dimensioning, similar to a high rupturing capacity fuse.
- Low let-through values: the contactors connected downstream are less stressed as the short circuit current is appreciably limited by the circuit breakers. Short-circuit co-ordination is simplified and it is not necessary to consult the short-circuit co-ordination tables (the manufacturers perform

tests for the short-circuit co-ordination and supply tables in accordance with the IEC 947-4-1 for, as for example, types "1" or "2"). The combination of a circuit breaker and a contactor, both selected on the basis of their rated currents, can in most of the cases fulfil the requirements of the type of co-ordination "2", without any other considerations.

1.2.2.4. Circuit breaker with motor protective characteristics

How to identify circuit breakers with motor protective characteristics

The inclusion of thermal, time-delayed overcurrent release is no sure indication that the particular circuit breaker is suitable for motor protection. The easy to confuse definition of circuit breakers for motor protection may also mean that it is suitable for motor protection only in association with a special motor protective device (the circuit breaker will not trip earlier than the special motor protective device, somewhat similar to the terminology of aM-type of fuses, the so called fuses for motor protection).

A true motor protection is directly integrated in the circuit breaker only if the thermal release is compensated for ambient air temperature in accordance with the IEC 947-4-1 and is also sensitive to phase-loss (popularly called single-phasing protection). In the case of electronic devices, attention is to be paid to the appropriate markings indicating motor protection. Usually, a standard circuit breaker provides protection only for the connecting wiring.

Circuit breakers for motor protection are characterised by at least the following features :

- Adjustable thermal (bimetallic) release, setting equal to the motor current (or electronic release)
- Ambient air temperature compensation (in the case of bimetal)
- Reliable arrangement for the protection of the motor in the case of phase-loss (as for example: special calibration, differential protection or electronic phase-loss detector) so that they are suitable for the EEx e type of motors.

1.2.2.5. Circuit breaker for the protection of installations and connecting leads

The requirements for the circuit breakers for the protection of installations and connecting leads are somewhat less demanding :

- The current range is often fixed
- The thermal release is less precise
- The ambient air temperature compensation is absent
- The tripping threshold of the magnetic short-circuit tripping is mostly lower (as for example $3.4 \times I_n$)
- In some cases, they interrupt the short-circuit with a time delay

These time-staggered circuit breakers are suitable for the so called selective (or discriminating) load feeders. The integrated tripping device, mostly electronic, permits the inclusion of an OFF-time-delay of a few half-cycles, in addition to the setting of the overload and the short-circuit tripping threshold.

These circuit breakers are used for the protection of installations (back-up protection, protection of the connecting wiring, switching in cascade (series) of circuit breakers, selective feeders) and not for the protection of individual load feeders like motors.

The protection of the connecting wiring can be realised with thermal (bimetallic) releases without ambient air temperature compensation or with relatively simple electronic protective devices. The protection of a motor with the above mentioned circuit breaker is possible together with an additional motor protective device only.

1.2.3. Load-break switch

The load break switch is a mechanical switching device capable of making, carrying and breaking currents under normal circuit conditions which may include specified operating overload conditions and also carrying for a specified time currents under specified abnormal circuit conditions such as those of short-circuit.

A load switch may be capable of making but not breaking, short-circuit currents (IEC 947-1). It is capable of carrying (high short-time withstand capability) but not breaking the short-circuit currents.

1.2.4. Disconnecter

A mechanical switching device which, in the open position, complies with the requirements specified for isolating function (IEC 947-1). The isolating device must disconnect the supply voltage from the whole installation or from part of the installation, thereby for ensuring safety, the whole installation or part of the installation must be completely isolated from all sources of electrical energy. The important factor here is the isolating distance. The isolation of pole to pole or between the incoming and outgoing terminals must be assured, be it with a visible isolating gap or with the help of appropriate internal constructive measures (mechanical interlocking device).

A device meets the requirements of isolating function in accordance with the IEC 947-1 if it provides an isolating distance in the "OFF" position so that the

prescribed dielectric strength between the open contacts of the main current path of the switch is assured. Additionally, it must be provided with an indicator which shows the position of the moving contacts. This switching position indicator must be mechanically connected to the operating mechanism in a reliable and robust way. The operating mechanism itself may serve the purpose of the switching position indicator provided in the "TRIP" position it indicates the position "OFF" only when all the moving contacts are in the "OFF" position.

A disconnecter is capable of opening and closing a circuit when either a negligible current is broken or made, or when no significant change in the voltage across the terminals of each of the poles of the disconnecter occurs. It is also capable of carrying currents under normal circuit conditions and carrying for a specified time currents under abnormal conditions such as those of short-circuit.

1.2.5. Main switch

Every electrical equipment must be provided with a manual main switch which completely disconnects the equipment from the supplies so that cleaning, maintenance or repairs can be carried out or if the machine is to be taken out of service for a longer period of time.

- A main switch must meet the requirements of a switch-disconnector in accordance with the IEC 947-3 (load switch with isolating function - see above). It must at least meet the requirements of the utilisation category AC-23.
- A main switch is manually operated and must have only one "OFF" and one "ON" position, which are to be clearly marked with O and I respectively.
- A main switch must have a visible isolating gap or an unambiguous indication of the "OFF" position of the switch as soon as the gap between the contacts has reached the prescribed isolating distance in accordance with the IEC 947-3.
- As long as the main switch do not serve the purpose of an emergency OFF-switch at the same time, it may not have a red operating handle.
- It must be possible to lock-out the handle in the OFF-position (as for example with a padlock).

If necessary, it must be possible to interlock the main switch with a door with the help of an interlocking device.

The supply of the following circuits must not necessarily be over the main switch:

- Connections for lamps required for maintenance works
- Socket outlets, exclusively for machines like drilling machines necessary for servicing.

A main switch placed within the reach of an operator must fulfil the requirements of an emergency OFF-switch.

1.2.6. Emergency OFF-switch

In the case of a danger to persons or machines, the part in danger or the whole machine itself must be quickly isolated from the supply and brought to stand-still with the help of an emergency OFF-switch.

- The emergency OFF-switch must be capable of interrupting the locked-rotor current of the largest motor connected to it and added to it, the sum of the rated currents of all the other loads connected to the same switch.
- The contacts must fulfil the isolating function.
- The operating handle or button must be clearly visible by the operator from his operating position and must be located within his easy reach.
- The operating handle or button must be coloured red. The background or mounting surface must be coloured yellow so that the handle or the button clearly stands out against the background.
- The emergency OFF-switch must not disconnect an electrical circuit, which when disconnected may lead to danger to persons or to machines.
- It must be capable of carrying continuously the sum of the rated currents of all the loads connected to it.

1.2.7. Summary: circuit breaker as load break switch

Requirements of load break switch (IEC 204)	Main switch	Emergency OFF-switch	Emergency OFF-Main switch
Operating element:			
- Black or grey handle and front plate	Yes	No	No
- Red handle, yellow front plate	No	Yes	Yes
- Can be locked out	Yes	No	Yes
Manual operation from outside	No	Yes	Yes
Easily accessible	Yes	Yes	Yes
Only one "ON" and "OFF" position	Yes	Yes	Yes
Position indication "O" and "I" only	Yes	Yes	Yes
Can be locked out in "O"-position from outside	Yes	No	Yes
Protected input terminals with warning symbol	Yes	No	Yes

1.3. Design of a circuit breaker

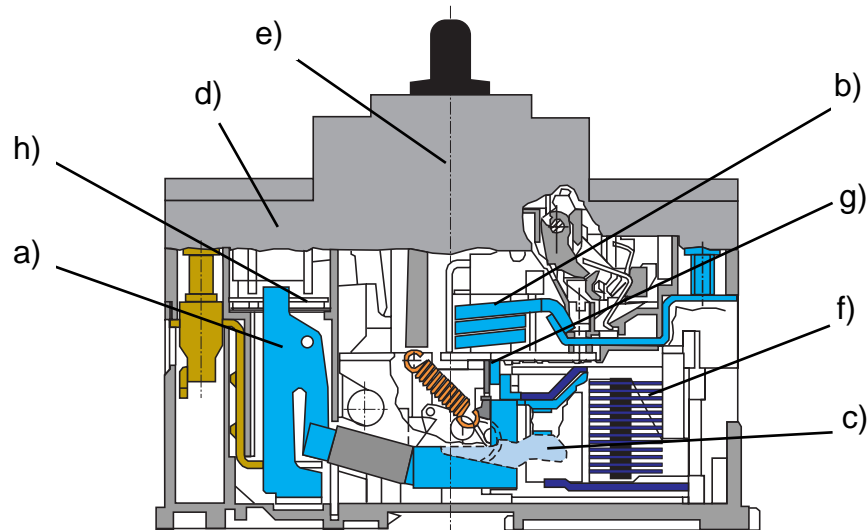

Fig. 1.3-1: The principal functional blocks of a circuit breaker

- a) Thermal overcurrent release*
- b) Magnetic overcurrent release*
- c) Main contact system*
- d) Auxiliary contacts*
- e) Operating mechanism*
- f) Arc chamber (splitter plates)*
- g) Striker (hammer)*
- h) Sliding piece for differential protection*

The functional blocks of a circuit breaker indicated in the illustration above are complimentary to one another. They are designed in such a way that the mutual task, the quick interruption of the short-circuit current and reliable detection of the overload condition, is optimally fulfilled.

More and more of the circuit breakers in the higher current ranges (approximately >250A) are making use of micro-processors. Electronic releases for short-circuit and overload are incorporated and they are capable of communication with PLCs (Programmable Logic Controllers) or with other management or guidance systems.

1.3.1. The current path of the circuit breaker

The normal rated current as well as the short-circuit or the overload current flows from the incoming to the outgoing terminal of the circuit breaker through the magnetic and the thermal overload releases in series with the main contacts.

Exactly the same current flows through all the functional modules. Unequal amplitude and duration of the currents in the different releases will obviously cause different individual reactions.

1.3.2. Thermal overload release

Normal service overloads do not immediately cause any dangerous unbearable stress to the equipment. The built-in thermally delayed bimetallic motor protective release is sufficient for the usual and simple overload protective tasks.

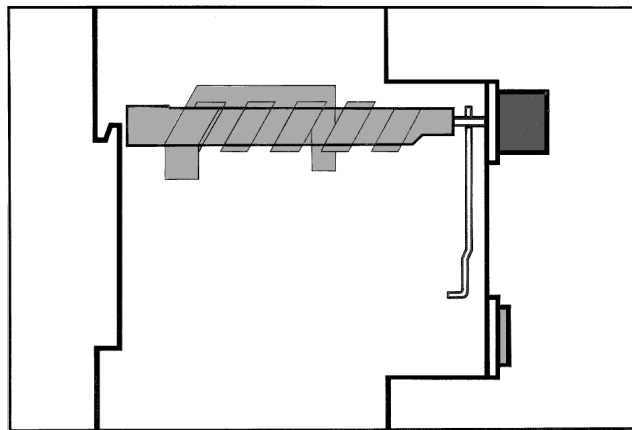

Fig. 1.3-2: The motor current flowing through the bimetallic strip of the thermal overload release heats it and thereby bends it. Depending on the current setting, it presses against the release latch of the operating mechanism.

In the circuit breakers also, the current flows through the thermally delayed bimetallic release. The bimetal bends, the amount of bending depends on its temperature, and presses against the release latch of the operating mechanism. The temperature-rise of the bimetal depends on the heating energy generated by the current flowing through the circuit breaker. The release threshold, in other words the travel of the tip of the bimetallic strip necessary for tripping the release latch, is adjusted with the help of the current setting dial.

If the release latch is pressed, it trips the operating mechanism thereby opens the main contacts and the overcurrent is interrupted before it can cause any damage to the motor winding, the connecting wiring or similar parts.

1.3.3. Electromagnetic overcurrent release

In the case of circuit breakers with motor protective characteristic, the electromagnetic overcurrent release is activated almost instantaneously when an overcurrent of 10...16 times of the maximum current-setting flows through the device. The exact operating threshold is either adjustable (depending on whether

selectivity is desired or on the different inrush peak current of transformers or if the device is to be employed for the protection of generators) or is fixed through its design. The threshold is lower for circuit breakers used for the protection of installations and the connecting wiring.

In the case of smaller circuit breakers (mostly <100A), a small coil is introduced in the main current path. As a high current (overcurrent) flows through the windings of the coil, an electromagnetic force acts on the armature enclosed inside the coil and accelerates it. This armature or the striker hits the spring-loaded releasing latch of the operating mechanism, the main contacts spring back to the position "OPEN" and the overcurrent is interrupted.

Working principle of quick acting, strongly current limiting circuit breakers

All mechanical systems with masses have inherently an inertia. These are in the range of a few milliseconds and may appear to be negligible on superficial consideration. However, in the design of quick acting, strongly current limiting circuit breakers, where the high prospective short-circuit current is to be limited and interrupted right during its initiation, the designer will have to consider the mass-inertia of all the moving parts like the main contacts, springs and levers and try to save even fractions of milliseconds from the total breaking time. The short-circuit current reaches its peak value after a quarter of the sinusoidal period, which is 5 milliseconds for 50Hz supply (4.2ms in the case of 60Hz as in the USA), assuming that the current is symmetrical, i.e. initiated at a current-zero. This is to be prevented.

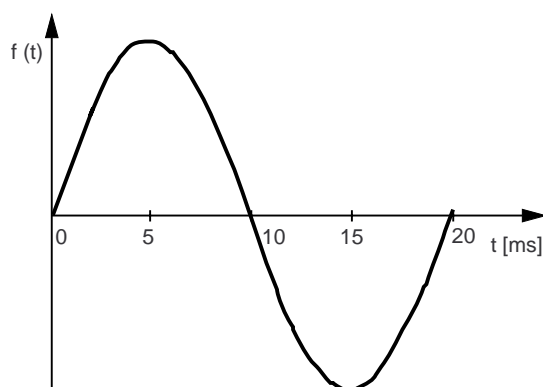

Fig. 1.3-3: Sinusoidal 50Hz current wave. The peak value is reached after a quarter of the period.

The electromagnetic overcurrent release itself acts almost instantaneously (< 1ms) with the rapidly rising current. It is the following mechanical release mechanism which is comparatively sluggish. This disadvantage is overcome in the case of quick acting current limiting circuit breakers by by-passing the

mechanism and let the armature of the magnetic release in the form of a striking hammer hit the moving main contacts directly. The contacts are thrown open even before the operating mechanism has started to react. The job of the mechanism would be to retain the contacts in the "OPEN" position and prevent their falling back and reclosing of the current path.

Only after the contacts are opened, an arc is struck between the contacts, which in its turn limits the short-circuit current to acceptable values and ultimately breaks it.

Circuit breakers in the lower range of currents up to about 100A are usually constructed based on the above principle of electromagnetic striker.

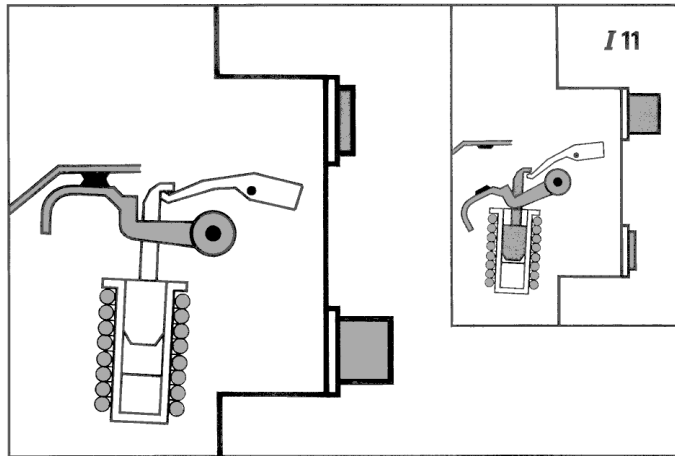

Fig. 1.3-4: Principle of the electromagnetic striker. The strong magnetic field, induced by the high current in the coil, accelerates the striker which hits the main moving contact practically without any time delay.

1.3.4. Main contact system

The requirements of the main contacts of a circuit breaker:

- High making capacity
- High breaking capacity
- Carrying of the rated current with low power dissipation
- Low rate of erosion of the contacts
- Low contact resistance (low millivolt drop)
- Low mass-inertia of the moving parts
- Optimised arc chamber, so that the arc is quickly guided to it
- Economic design (low manufacturing cost)

To realise the above, an in-depth, thorough knowledge of physics and material sciences is absolutely necessary on the part of the designers. No single material or form of the parts will meet all the requirements. Compromises are to be made

and the results to be verified with complicated computer modelling as well as with the help of elaborate tests in the short-circuit testing laboratories.

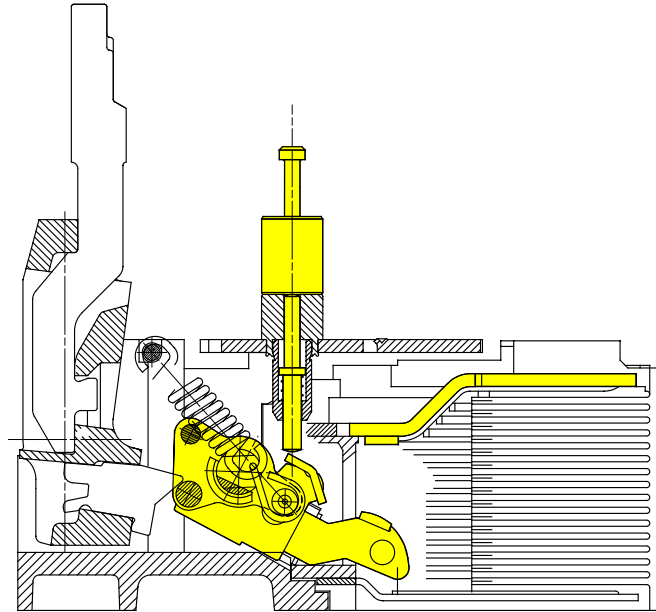

Fig. 1.3-5: The main contacts of the circuit breaker 140-CMN

The same is true for the design of the arc chamber. The arc is to be guided quickly away from the contact tips to the splitter plates (also called de-ion plates), cooled, elongated and ultimately "splitted" into smaller part arcs so that the arc can be quenched and the short-circuit interrupted. To achieve this, the whole arc chamber together with the form, position and arrangement of the splitter plates must form an optimised functional unit with the main contacts.

A contact system is optimised for a particular rated supply voltage from the point of view of its switching capabilities. As for example a contact system designed primarily for 400V may have a reduced breaking capacity at voltages above 400V (at supply voltages lower than 400V, it is not critical). The reason of the reduction is the following : for quenching the arc due to the short-circuit current inside the arc chamber, an arc voltage which opposes the supply voltage is built-up between the contacts. The value of the arc voltage depends on the design of the contact system and the arc chamber (number of splitter plates and other factors). As long as this opposing voltage has a particular high value in relation to the supply voltage, the short-circuit currents can be efficiently limited and the arc quenched rapidly.

For this reason, a circuit breaker designed primarily for 400V may have a reduced breaking capacity at 690V.

Current interrupting process during a short-circuit:

Industrial current carrying circuits are practically without exception inductive. Due to the inductance L , which also includes the inductance of the connecting wiring, a magnetic energy as a function of the current i flowing is stored in the circuit as represented in the equation (1). This has also an influence on the current interrupting process as shown in equation (2) :

$$E_{magn} = \frac{1}{2} Li^2 \quad (1)$$

$$u_n = Ri + L \frac{di}{dt} + u_s \quad (2)$$

$$\int u_n idt = \int Ri^2 dt + \frac{1}{2} Li^2 + \int u_s idt \quad (3)$$

During the breaking process in accordance with the equation (3), the stored magnetic energy as well as the energy subsequently supplied by the mains are to be considered. In the following figure, a short-circuit breaking operation with the help of a circuit breaker is illustrated. The normal operating current flowing before the occurrence of the short-circuit can be neglected so that it is sufficient to consider the elements of the short-circuit only. If a fault occurs and as long as the protective device do not react, the rate of rise of the short-circuit current is very high. After a certain delay, depending on the reaction time of the circuit breaker, the contacts start opening, an arc is struck between the contacts which is driven towards the arc chamber and the arc voltage opposing the supply voltage increases due to elongation, cooling and splitting. This causes a limitation of the increasing short-circuit current and ultimately forces the current to an artificial current-zero and the arc is quenched. The value of the voltage across the contacts (arc voltage) is an indication of the efficiency of the switching device and also shows the influence of the circuit breaker on the electrical circuit.

a) The shape of the current and the voltage curves b) The equivalent electrical circuit

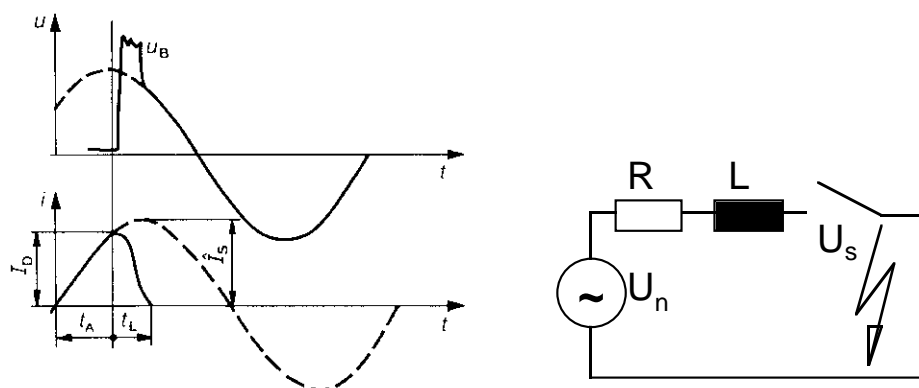

Fig. 1.3-6: Short-circuit breaking operation in a low-voltage circuit with $U_n=230V$, $I_k=10kA$, $R=15.4m\Omega$, $L=85\mu H$ and $\cos \varphi=0.5$.
 u_s =Voltage across the contacts (arc voltage)

1.3.5. Auxiliary contacts

The auxiliary contacts are the connecting elements (interfaces) between the protective device and the control functions. "ON"- or "OFF"-position, overload or short-circuit tripping can be indicated and signalled with the help of the appropriate auxiliary contacts. These auxiliary contacts can be flush mounted (internal) or surface mounted (external) on to the circuit breakers. The ends are brought out to terminal blocks or hangs out as wire ends which could be connected externally to other devices.

1.3.6. Operating mechanism

The operating mechanism is a device for storing the spring energy which is supplied during the switching-on of the circuit breaker and is set free during the breaking operation for bringing the main contacts to the open position.

The operating mechanism is the mechanical functional centre of the circuit breaker. Information regarding overload and short-circuit as well as manual or remote controlled operations on the circuit breaker is passed on to the main and the auxiliary contacts. The main contacts which are kept closed with relatively high contact force must be opened with lower releasing force. Visual signalisation of the switching position or of the trip-position are indicated on the front face of the circuit breaker.

Additionally, a trip-free operation must be assured. This means that the breaking operation of the circuit breaker is still possible even if the operating handle is outwardly blocked or if the circuit breaker is switched-on on to a short-circuit.

1.4. Functions of a circuit breaker

A circuit breaker unifies many features in one single device and thus is a powerful functional unit in distribution and installations.

The following functions are unified in one single device together with its appropriate accessories:

- Short-circuit protection
- Motor protection
- Protection of connecting wiring
- Protection of installations
- Indication of the switching state
- Tripping indication
- Remote operation
- Isolating and disconnecting functions
- Locking out with a padlock

Especially in the lower range of currents, it also takes over the function of switching under normal service conditions as a manual switching device.

1.4.1. Interrupting short-circuit current

As an example, let us consider a quick acting, current limiting circuit breaker as described previously.

To limit the short-circuit current already at its initiation, the main contacts must be opened by the striker within a few milliseconds. A very fast acting device may need less than 1ms for this. An arc is struck immediately, which driven towards the arc chamber, delivers a high arc voltage. As a simplification, the arc voltage can be considered as an equivalent additional resistance connected in series to the current circuit which immediately limits the rising short-circuit current.

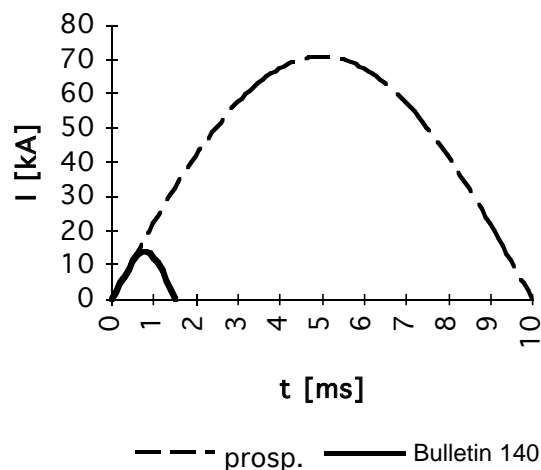

Fig. 1.4-1: Let-through (cut-off) current of the fast acting circuit breaker 140M theoretical prospective short-circuit current of 50kA symmetrical r.m.s. value (dashed line) is limited already at its stage of initiation by the fast acting circuit breaker (full line). A current-zero interrupting type of circuit breaker will let through almost the full sinusoidal half-cycle of the short-circuit current.

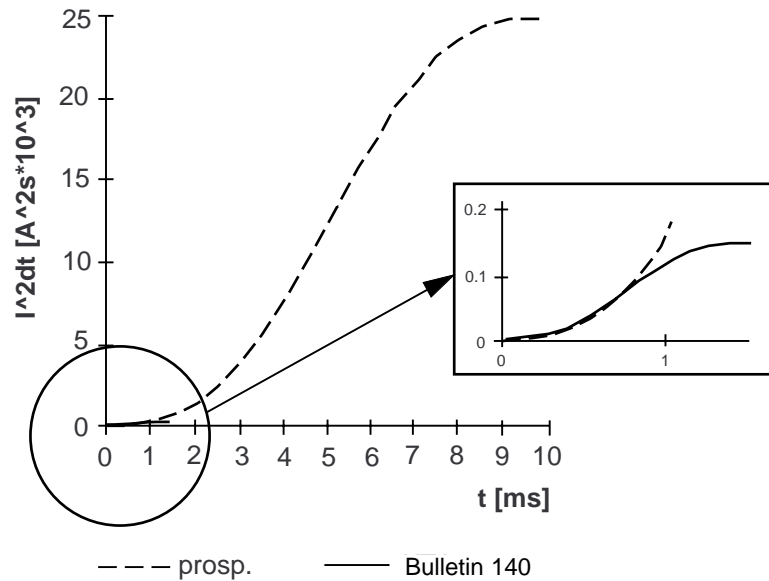

Fig. 1.4-2: Let-through energy (Joule integral) of the fast acting circuit breaker 140M

The energy of the short-circuit current integrated over a time period, also called the let-through energy I^2t (Joule integral), indicates how the components installed downstream of the circuit breaker, especially switching devices like a contactor, are less stressed when protected by a current limiting circuit breaker instead of a current-zero interrupting type.

Note : Although popularly called the let-through energy, the Joule-Integral gives only an indication of the let-through energy and do not have the dimension of energy. The Joule-Integral multiplied the resistance of the current path is actually the let-through energy.

The resulting low let-through values of the current limiting circuit breaker cause no or very little damage to the components or devices installed downstream of the circuit breaker. With the right choice of the various components, strongly welded contacts of contactors or severe damage to the connecting wiring or bus-bars due to uncontrolled arcing can be prevented.

1.4.2. Reliable protection of motors

Circuit breakers with motor protective characteristics in accordance with the IEC 947-4, meet the requirements of a thermal overload motor protection relay. Adjustable, current dependant time-delayed overcurrent release protects against thermal overloading. The ambient air temperature compensation and a precise calibration of the overcurrent release mechanism assures an exact and reliable tripping. Often a differential release for the protection against the loss of a phase

is integrated in the device. After the interruption of a short-circuit, the tripping characteristic must not alter without any outwardly visible indication.

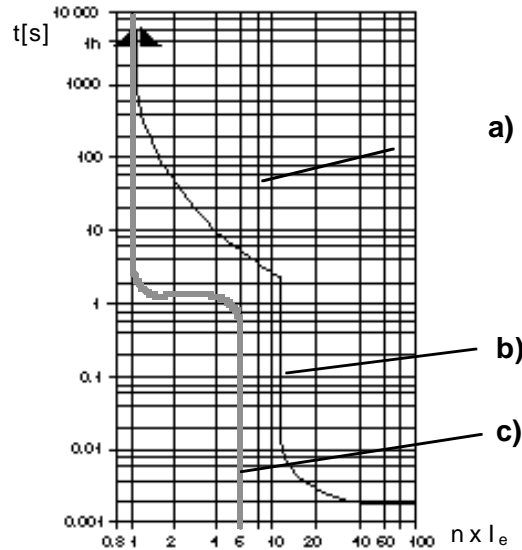

Fig. 1.4-3: Tripping curve of a circuit breaker with motor protective characteristic. The grey line indicates the current form of a normal motor. After the rated speed is reached (here after about 1.5s), the starting current ($6 \times I_n$) reduces to the rated current of the motor ($1 \times I_n$).

- a) Time-current characteristic of the bimetallic release
- b) Time-current characteristic of the magnetic release
- c) Characteristic of the motor

1.4.3. Protection of leads and its optimum utilisation

For the protection of the connecting leads, a circuit breaker with a simple over-current release without compensation of the ambient air temperature is fully sufficient.

Circuit breaker with motor protective characteristic automatically offers protection to the connecting wiring (wiring is thermally less critical than motor). Because of the possibility of setting the current dial of the circuit breaker to the rated current of the motor, the cross-section of the leads can be chosen, depending on the prevalent national standard, either in accordance with the current setting or in accordance with the upper limit of the current setting scale. In the case of fuses of type gI, a slight over dimensioning of the fuse by one or two steps of current rating (to avoid the melting of the fuse during starting) requires a corresponding increase of the cross-section of the connecting wiring. For wiring protected with a circuit breaker, smaller cross-section for the wiring can be taken and the leads are better utilised.

1.4.4. Protection of installations

For the protection of installations, circuit breaker without compensation of the ambient air temperature is permissible. In most of the cases, it need not be current limiting but selectivity may be called for as an additional feature.

Current limiting circuit breakers, due to its low let-through values not only causes less damage to the switching devices connected downstream in the case of a short-circuit, but also produces less thermal and mechanical stress on the parts of the installation like bus-bars or cables. Especially due to the reduced electro-dynamic forces between neighbouring, parallel current carrying conductors, often a mechanically less robust construction than in the case of a current-zero interrupting type of circuit breaker is permitted. The bus-bars and conductors protected by current limiting circuit breakers can be supported with less number of supports and the number of mechanical re-enforcement can be reduced. Larger distances between the bus-bar supports are permitted (the distances between the bus-bar supports depend on the short-circuit current, with a circuit breaker in the circuit on the let-through current of the circuit breaker. Please follow the instructions of the manufacturers of the system of bus-bars).

1.4.5. Integration in the control circuit

With increasing degree of automation, the significance of showing the operational status of the switching and protective devices are also gaining in importance. The circuit breaker can be easily integrated in this flow of information in an installation. It can communicate with the control circuit.

- Auxiliary contacts show the status of the load feeders, whether they are switched on or off.
- Signalling contacts supply information about the tripping condition of the breaker. Often it is possible to obtain separate information on whether the magnetic trip (short-circuit) or the thermal trip (overload) operated. Direct, fault correcting steps can be taken (quick localisation of fault means time saving).
- The shunt trip permits a remote controlled breaking operation, as for example electrical interlocking of circuit breakers between one another.
- Prevention of automatic starting of a motor after a supply interruption for safety purposes is possible with the under-voltage release. It may also serve the purposes of an emergency OFF-function.

- The complete control of the circuit breaker from a distance is possible with the help of motors or remote-controlled drives. The manual operations performed on the rotating handle can be also realised through remote-controlled devices. Without the intervention of any operating person at the site, load feeders may be switched on or off.

The remote-controlled resetting of a tripped circuit breaker in a distribution network is also possible.

In many applications, the remotely controlled circuit breaker which can be switched on or off may replace a latched contactor (as for example switching tasks in supplies with frequent voltage dips or interruptions, impulse contact control without sealing burden, stand-by generating sets).

1.4.6. Switching under normal service conditions

In the lower range of current, circuit breakers are frequently employed for manually operated normal service applications for small, often mobile plants. The potential electrical life of the breaker will be hardly utilised for these applications with low number of operations. The compact circuit breaker replaces the combination of fuse, motor protective device and the load switch (as for example mobile table mounted milling machine, mobile submerged pumps).

1.4.7. Disconnecting function

The requirements of a disconnecter as defined in the IEC 947-1 (see the definitions in the beginning) can be met by circuit breakers with lockable handle (please follow the instructions of the manufacturers regarding the observance of the isolating function).

1.4.8. Locking out with a padlock

If maintenance or other works are to be performed with the machines or at an installation, it should be possible to lock out the main switch with the help of a padlock. Circuit breakers with the provision for locking out with a padlock fulfil this requirement of the standard also, without much additional adaptation.

2. Circuit breaker technology

2.1. Summary

For the application of circuit breakers as motor starters, we have to consider the technical aspects in connection with the following subjects : calculation of short-circuit currents in the supply system, selection of breakers on the basis of making/breaking capacities, consideration of selectivity, starting or service under heavy-duty conditions and the right selection for the appropriate short-circuit co-ordination.

The modern circuit breaker, with its effective current limiting features, has the advantage that in most of the cases the clarification of all these time consuming technical problems is superfluous. The specially designed modern circuit breakers take over their allotted task as an integral component of the starter combination.

The short circuit co-ordination type "2" conforming to the IEC 947-4-1 (no damage to the combination, the starter suitable for further use after the interruption of the short-circuit) can be automatically achieved by selecting the standard components (as for example 140M + contactor) on the basis of the rated motor currents, without taking resort to over-dimensioning of the contactors.

Provided that the ultimate short-circuit breaking capacity of the circuit breaker is high enough (as for example $I_{cu} = 50 \text{ kA}$, 400V), the circuit breaker, independent of its point of installation, can rapidly and reliably identify, bring under control and interrupt any short-circuit current which may occur. Time consuming and sometimes only inaccurate calculation of the short-circuit current is no longer necessary.

The present day circuit breaker technology simplifies the planning of installations without fuses (fuse-free distribution), especially for motor starters. In spite of the above, to understand all the aspects in connection with the application of circuit breakers, the following subjects will be discussed :

- Calculation of the short-circuit currents at the point of installation of the circuit breaker
- Consideration of selectivity (discrimination) and breaking/making capacities in the case of a short-circuit
- Overload protection under special conditions
- Short-circuit coordination

2.2. Short-circuit current in supply systems

A short-circuit is an abnormal condition of the supply system, caused by a damage or "short-circuiting" of the normal insulation of the system. The task of a Short-Circuit Protective Device (SCPD) is to bring the effects of this faulty condition under control and reduce the damages which it may cause.

For the appropriate selection of the protective device on the basis of its switching capacity or discrimination, the expected short-circuit current at the point of installation must be known. This is a necessary condition for both circuit breaker and fuse. If the actual short-circuit current is higher than the switching capacity of the protective device, a reliable interruption of the short-circuit current is not fully assured. Extensive damage and service interruption could be the result. The value of the highest possible short-circuit current (the prospective short-circuit current) depends primarily on : the impedance of the fault, the distance to the supply system, the cross-section of the conductors and the different devices lying between the fault and the supply, the capacity of the supply source (ratings of the transformers, generators) and the type of supply system.

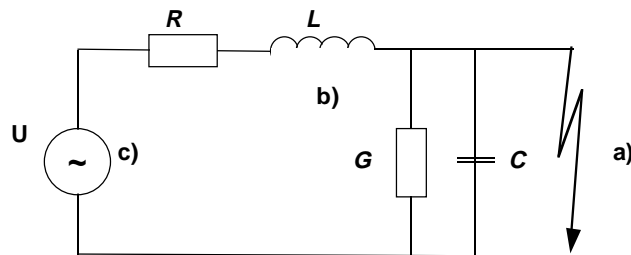

Fig. 2.2-1: Factors on which the actual short-circuit current depend.
 a) Impedance of the fault. b) Internal impedances of the connecting leads and devices c) Size (rating) of the source.

One must differentiate between :

2.2.1. Types of short-circuit

In a 3-phase supply system, short-circuits may occur between all the three line conductors, between two line conductors, between one line conductor and the neutral or the earth conductor. Further is the fault away from the source, lower is the short-circuit current. The connecting leads and the devices lying in between help to limit the current. The maximum value of the short-circuit current is attained if a 3-pole or a 1-pole (phase to neutral or earth) short-circuit occurs just across the low-voltage terminals of the transformer, provided the transformer is the only source of supply for the short-circuit.

For the sake of simplicity, we assume a stiff supply (infinite bus). This means that the influence of the high voltage side on the short-circuit current is negligible.

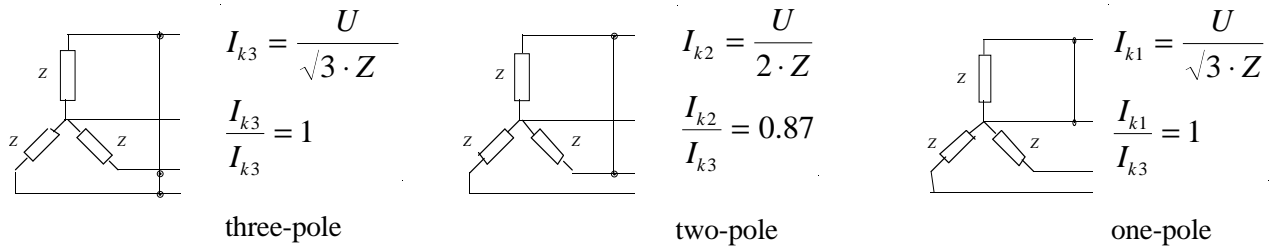

Fig. 2.2-2: Types of short-circuit and the magnitudes of the short-circuit currents in 3-phase supply systems.

The magnitude of the short-circuit current depends on the type of short-circuit and the distance of the fault from the transformer. The maximum value of the short-circuit current is attained if a 3-pole or a 1-pole (phase to neutral or earth) short-circuit occurs just across the low-voltage terminals of the transformer.

2.2.2. The peak value of the short-circuit current

Usually, a short-circuit does not occur at the natural current-zero of the steady-state short-circuit current. For this reason, an asymmetrical component (the d.c. component) is super-imposed on the symmetrical short-circuit current.

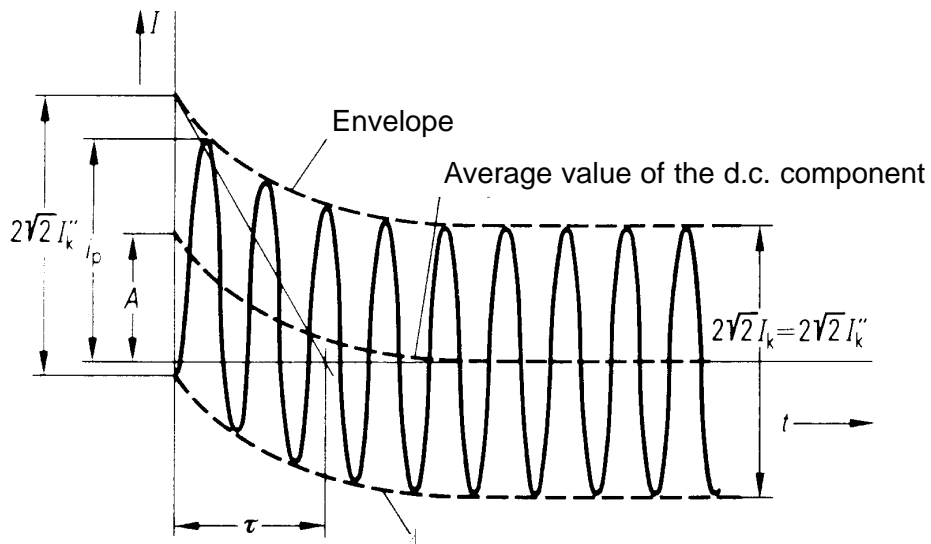

Fig. 2.2-3: Transient stage of the short-circuit current
Form of the short-circuit current for a short-circuit away from the generator. Initiation of the short-circuit at voltage-zero, asymmetrical d.c. component.

In the case of an asymmetrical short-circuit current, the maximum value at the beginning of the short-circuit is higher than the peak value of the steady-state short-circuit current by a factor. This factor κ (Kappa) depends on the ratio of the resistance to the reactance of the branch circuit (i.e. on the p.f. of the circuit) and can be read out from the following diagram for the calculation of the possible peak value of the current at the beginning $I_s = \kappa \cdot \sqrt{2} \cdot I_K''$

The electro-dynamic stress on the current carrying parts depends on this peak value I_s .

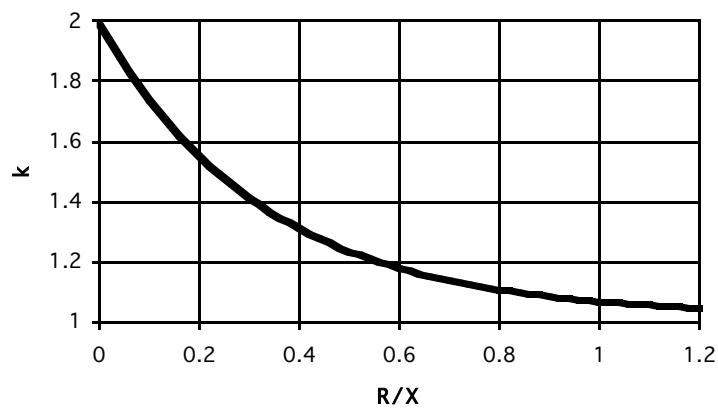

Fig. 2.2-4: The factor κ as a function of R/X defines the peak value of the asymmetrical short-circuit current ($\kappa = 1.022 + 0.96899 \cdot e^{-3.0301 \cdot R/X}$).

In practical applications, the value of this factor κ lies mostly between 1.1...1.5.

2.2.3. Calculation of the short-circuit current close to the transformer

For the sake of simplification, it will be assumed that the medium or the high voltage supply system to which the transformer is connected has a very high or even infinitely high short-circuit capacity (this is the most critical case, i.e. the current limiting influence of the impedances at the primary side is considered to be negligible).

If the circuit breaker is used as a main switch, as a transfer switch or as a distribution breaker close to the transformer, a rough estimate of the short-circuit current is sufficient (no significant current limiting factors other than the impedance drop of the transformer). The percentage impedance of the transformer (in German, it is expressed as a voltage called the short-circuit voltage U_k) can be read out from the name plate and the short-circuit current can be calculated with the help of a simple rule : the transformer rated current divided by the short-circuit voltage (as factor) is equal to the short-circuit current.

$$I_{k''} = I_{N \text{ Trafo}} \times 100/U_k$$

where:

$I_{k''}$ Short-circuit current (A)

$I_{N \text{ Trafo}}$ Rated current of the transformer.

U_k Short-circuit voltage (percentage impedance) in %.

The rated current of the transformer $I_{N \text{ Trafo}}$ is calculated as follows :

$$I_{N \text{ Trafo}} = \frac{S_{\text{Trafo}} \cdot 1000}{\sqrt{3} \cdot U}$$

S_{Trafo} Rating of the transformer kVA.

U Rated voltage at the low tension side in V.

An example : A transformer with

$$S_{\text{Trafo}} = 1000 \text{ kVA}; U_k = 4\%; U = 400 \text{ V}$$

$$I_{N \text{ Trafo}} = \frac{S_{\text{Trafo}} \cdot 1000}{\sqrt{3} \cdot U} = \frac{1000 \text{ kVA} \cdot 1000}{\sqrt{3} \cdot 400 \text{ V}} = 1443 \text{ A}$$

$$I_{k''} = I_{N \text{ Trafo}} \cdot \frac{100}{U_k} = 1443 \text{ A} \cdot \frac{100\%}{4\%} = 36'075 \text{ A}$$

In this example, the short-circuit current close to the transformer is 36 kA. The breaking capacity of the circuit breaker installed at this point must be higher than this value. If a high breaking capacity circuit breaker with an ultimate short-circuit breaking capacity $I_{cu} = 50 \text{ kA}$ or higher is used here, it is immaterial whether the simple formula used above is sufficiently accurate or not. The selected circuit breaker will have enough capacity in reserve.

The short-circuit current calculated above can also be read out directly from the table "Rated and short-circuit currents of 3-phase standard transformers".

Table Fig. 2.2-5: Rated and short-circuit currents of 3-phase standard transformers.

Secondary rated voltage 400/230 V

Rating [kVA]	Rated current [A]	Short-circuit voltage Uk	
		4%	6%
		Short-circuit current	
		[A]	[A]
50	72	1805	1203
100	144	3610	2406
160	230	5776	3850
200	288	7220	4812
250	360	9025	6015
315	455	11375	7583
400	589	14450	9630
500	722	18050	12030
630	910	22750	15166
800	1156	28900	19260
1000	1444	36100	24060
1250	1805	45125	30080
1600	2312	57800	38530
2000	2882	72200	48120

Secondary rated voltage 690/400 V

Rating [kVA]	Rated current [A]	Short-circuit voltage Uk	
		4%	6%
		Short-circuit current	
		[A]	[A]
50	42	1042	696
100	84	2082	1392
160	133	3325	2230
200	168	4168	2784
250	210	5220	3560
315	263	6650	4380
400	336	8336	5568
500	420	10440	7120
630	526	13300	8760
800	672	16672	11136
1000	840	20840	13920
1250	1050	26060	17480
1600	1330	33300	22300
2000	1680	41690	27840

2.2.4. Calculation of the short-circuit current in radial supply system

If we consider a branch circuit going away from the point of supply and follow it radially along all the connections and branches, we shall find that further away we are from the transformer, lower is the value of the maximum possible short-circuit current. Each length of conductor or each device in the circuit provides an impedance which helps to reduce the short-circuit current. To calculate the level of the maximum short-circuit current which is still possible, all the impedances lying between the transformer and the circuit breaker must be considered, be it with the help of mathematical formulae or from simple diagrams.

The a.c.-impedance Z of a cable consists of the d.c.-resistance R and the a.c. inductive and capacitive reactances X_L and X_C according to the formula

$$Z = \sqrt{R^2 + X^2}$$

The capacitive reactance X_C of connecting cables and bus-bars are very low and can be neglected. In the following, it will no longer be mentioned.

Calculation of the d.c. resistance

The d.c. resistance is calculated with the help of the relation :

$$R = \frac{\rho \cdot l}{A}$$

R	D.C. Resistance of a conductor [Ω]
ρ	Specific resistance of the conductor material $\left[\frac{\Omega \cdot \text{mm}^2}{\text{m}} \right]$ (Copper : $\rho = 0.0175 \frac{\Omega \cdot \text{mm}^2}{\text{m}}$ / Aluminium : $\rho = 0.029 \frac{\Omega \cdot \text{mm}^2}{\text{m}}$)
l	Length of the conductor [m]
A	Cross-section of the conductor [mm^2]

Example : Resistance of a strand of copper connecting cable, length 50 m, cross-section 25 mm².

$$R = \frac{\rho \cdot l}{A} = \frac{0.0175 \frac{\Omega \cdot \text{mm}^2}{\text{m}} \cdot 250\text{m}}{25\text{mm}^2} = 35\text{m}\Omega$$

The ohmic resistance of copper and aluminium conductors can also be read out from the following table.

Table of ohmic resistance

Bus-bars				Cable (4 strands, plastic insulation)		
Size	Cross-section	Resistance		Cross-section	Resistance	
		Cu	Al		Cu	Al
[mm]	[mm ²]	[mΩ/m]	[mΩ/m]	[mm ²]	[mΩ/m]	[mΩ/m]
				0,75	23,73	
				1	17,80	
				1,5	11,87	
15x2	30	0,593	0,967	2,5	7,120	
15x3	45	0,396	0,644	4	4,450	
20x2	40	0,445	0,725	6	2,967	
20x3	60	0,297	0,483	10	1,780	2,900
20x5	100	0,178	0,290	16	1,112	1,813
25x5	125	0,142	0,232	25	0,712	1,160
30x3	90	0,197	0,322	35	0,508	0,829
30x5	150	0,118	0,193	50	0,356	0,580
40x3	120	0,148	0,242	70	0,254	0,414
40x5	200	0,089	0,145	95	0,187	0,305
40x10	400	0,044	0,072	120	0,148	0,242
50x5	250	0,071	0,011	150	0,118	0,193
50x10	500	0,035	0,058	185	0,096	0,157
60x5	300	0,059	0,096	240	0,074	0,121
60x10	600	0,029	0,047	300	0,059	0,097
80x5	400	0,044	0,072	400	0,044	0,073
80x10	800	0,022	0,036	500	0,035	0,058
100x10	1000	0,017	0,029			
120x10	1200	0,014	0,024			
140x10	1400	0,012	0,020			
160x10	1600	0,011	0,018			

Fig. 2.2-6: Ohmic resistance R per phase or strand of copper and aluminium conductors at 50 Hz and a conductor temperature of 20 °C

Higher temperature of the conductor

The calculated values as shown above or the values read out from the table are the values of the resistances at a conductor temperature of 20 °C.

In practical applications, the temperature of the conductors are higher due to the heating effect of the current flowing through the conductors and due to the accumulated heat inside the cable duct. This has an effect on the resistance of the conductors. An approximate way of calculating the resistance at a higher temperature is possible with the help of the relation :

$$R_{\vartheta 2} = R_{20} \cdot (1 + \alpha_{20} \cdot \Delta\vartheta)$$

For copper : $\alpha_{20} = 0.00393$
 For aluminium $\alpha_{20} = 0.00403\dots$

R_{ϑ_2} Resistance of the conductor at a higher temperature [Ω]
 R_{20} Resistance of the conductor at 20 °C [Ω]
 α_{20} Temperature co-efficient of the conductor material []
 $\Delta\vartheta$ Difference in temperature []

The increase in resistance due to higher temperature in the range of temperature-rise $\Delta T_L = + 20\dots 60$ °C is only a few percent. With that, the current limiting effect of the increased resistance is also negligible and hence it would be hardly possible to use a circuit breaker with lower breaking capacity. Especially, the temperature of the conductors is not constant. One must also consider the possibilities of a short-circuit over a conductor which is not fully loaded or even during the first switching on (commissioning) of the installation. Hence, the installation must be designed for conductors at the cold-state (worst case).

Frequency dependant impedances

The reactance X is calculated with the help of the following formula :

$$X = \omega \times L$$

X Reactance [Ω]
 ω Angular velocity [s^{-1}]
 $\omega = 2\pi f \rightarrow f$: supply frequency [Hz]
 L Inductivity of the connecting leads [H]

The inductivity of the connecting leads L has to be calculated, measured or, in a simplified form, can be read out from standardised tables.

Table of reactance

The values given in the table are for guidance only. Exact data are to be obtained from the manufacturers of the cables

Cross-section of the core A [mm ²]	Cable, 4-core X [mΩ/m]
1.5	0.115
2.5	0.110
4	0.107
6	0.100
10	0.094
16	0.090
25	0.086
35	0.083
50	0.083
70	0.082
95	0.082
120	0.080
150	0.080
185	0.080
240	0.079
300	0.079
400	0.079
500	0.078

Fig. 2.2-7: Reactance X of typical copper and aluminium cables at a conductor temperature of 20 °C and at 50 Hz (for other frequencies, consult the table "Frequency-dependence of the reactance").

Frequency-dependence of the reactance

From the formula for X it is apparent that there is a linear relation between the reactance and the frequency. Consequently, for other frequencies, the value of the reactance can be calculated proportional to the 50 Hz value.

$$X = \omega \cdot L = 2 \cdot \pi \cdot f \cdot L$$

$$X_{60\text{Hz}} = X_{50\text{Hz}} \cdot \frac{60\text{Hz}}{50\text{Hz}} = X_{50\text{Hz}} \cdot 1.2$$

Hence, reactance at 60 Hz is 20 % higher than the value given in the table.

Impedance of the connecting lead

The impedance of the connecting lead Z can now be calculated as the square-root of the quadratic sum of resistance and reactance :

$$Z = \sqrt{R^2 + X^2}$$

Z	Impedance [$m\Omega$]
R	Resistance [$m\Omega$]
X	Reactance [$m\Omega$]

An example with the above mentioned cable with cross-section of 25 mm^2 , $R = 35 \text{ m}\Omega$, $X_L = 50 \text{ m} \times 0.086 \text{ m}\Omega/\text{m} = 4.3 \text{ m}\Omega$

$$Z = \sqrt{R^2 + X^2} = \sqrt{(35 \text{ m}\Omega)^2 + (4.3 \text{ m}\Omega)^2} = 35.26 \text{ m}\Omega$$

Graphically :

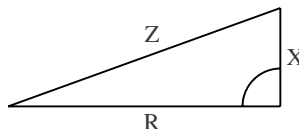

Short-circuit current at the end of the feeder

The expected short-circuit current at the end of the feeder is expressed by the relation :

$$I_{K''} = \frac{U_{N\text{Trafo}}}{\sqrt{3} \cdot (Z_{\text{Trafo}} + Z_{\text{Leitung}})}$$

$I_{K''}$	Short-circuit current [kA]
$U_{N \text{ Trafo}}$	Rated voltage of the supply transformer on the low-tension side [V]
Z_{Trafo}	Impedance of the transformer

$$Z_{\text{Trafo}} = \frac{U_N \cdot U_K \cdot 10}{\sqrt{3} \cdot I_N}$$

$Z_{\text{Conducting}}$ Impedance of the conducting lead

Additional example: Short-circuit current in a 3-phase supply with a 1000 kVA transformer, $U_K = 4 \%$, Line voltage 400 V, Length of the cable 50 m, 25 mm^2

$$Z_{\text{Trafo}} = \frac{U_N \cdot U_K \cdot 10}{\sqrt{3} \cdot I_N} = \frac{400 \text{ V} \cdot 4\% \cdot 10}{\sqrt{3} \cdot 1444 \text{ A}} = 6.40 \text{ m}\Omega$$

$$I_{K''} = \frac{U_{NTrafo}}{\sqrt{3} \cdot (Z_T + Z_L)} = \frac{400 \text{ V}}{\sqrt{3} \cdot (6.40 \text{ m}\Omega + 35.26 \text{ m}\Omega)} = 5.54 \text{ kA}$$

In this case, the circuit breaker which is to be installed at the end of the feeder must have a breaking capacity of only 5 kA at 400 V.

Method of solution with the help of diagrams

Diagram 1 (Impedance of transformer Z_T):

- Going up from the kVA-rating of the transformer (X-axis), read out the resistance R on the line R .
- Similarly, read out the reactance X on the line X with the appropriate short-circuit voltage (percentage impedance) U_K of the transformer.

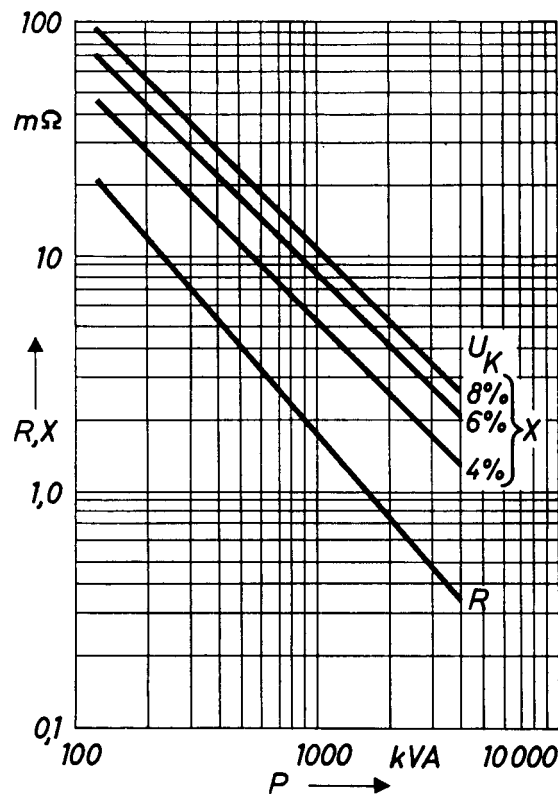

Fig. 2.2-8 Diagram 1: Resistances and reactances of 3-phase transformers at 400 V, 50 Hz.

Diagram 2 (Connecting lead Z_L):

- Read out the resistance R from the point of intersection of the length of the connecting lead and appropriate cross-section.
- Read out the reactance X from the lowest lying line and from the corresponding length of the connecting lead.

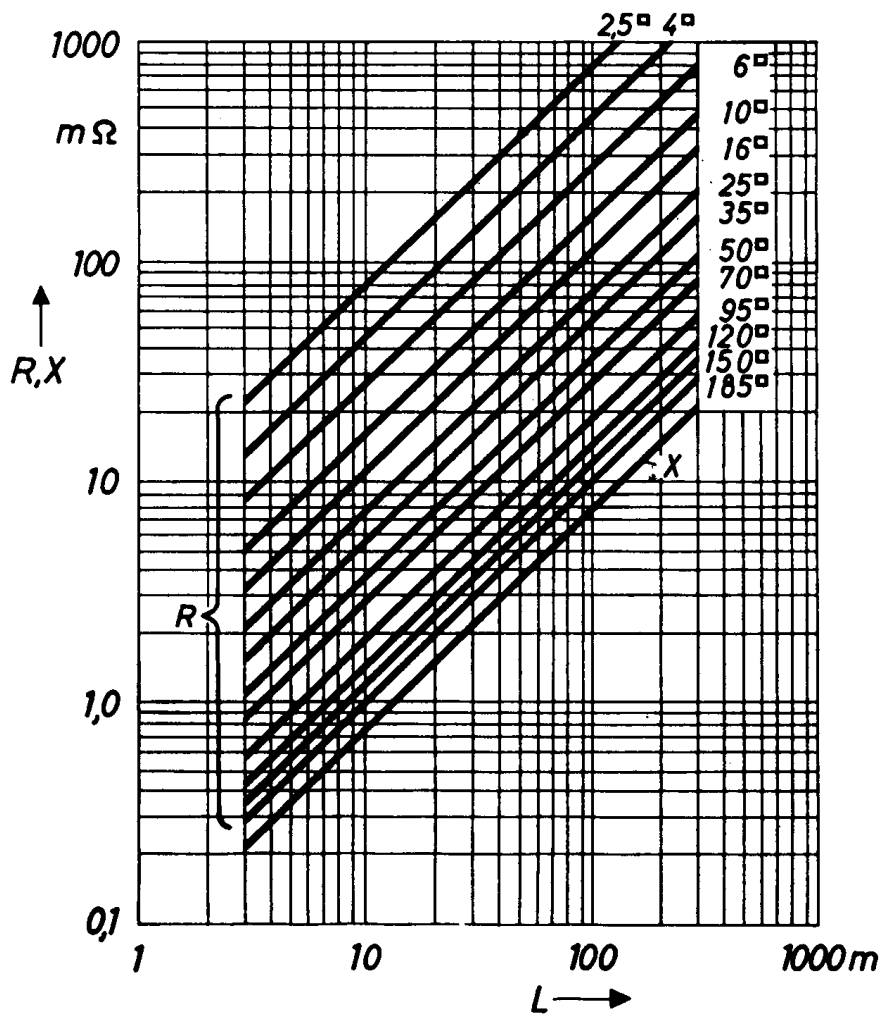

Fig. 2.2-9 Diagram 2: Resistance and reactance of cable and connecting leads

Diagram 3 (Short-circuit current at the end of the feeder I_K):

- With the help of the sum of the R and X values read out from the diagrams 1 and 2, interpolate the value of the I_K from the curves drawn in diagram 3.

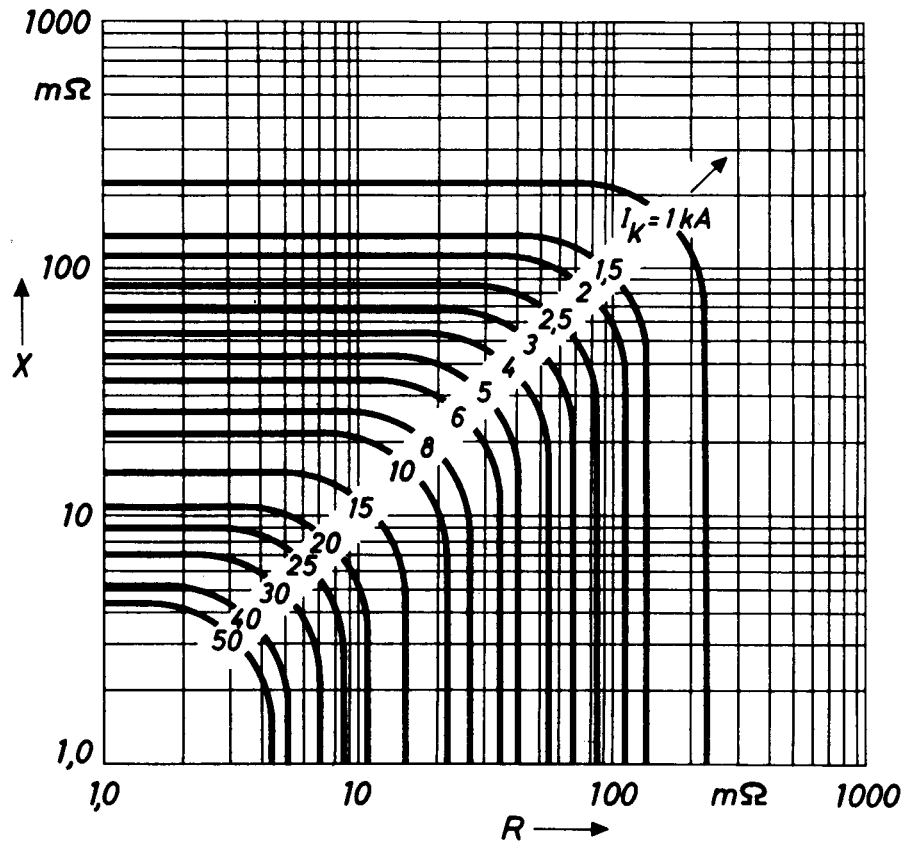

Fig. 2.2-10 Diagram 3: Short-circuit current I_K as a function of the total resistance R and the total reactance X of the path of the short-circuit at 400 V, 3-phase.

Example:

Copper cable, cross-section 25 mm², length 50 m

From the diagram 2 : $R = 35 \text{ m}\Omega$, $X = 3.5 \text{ m}\Omega$

From the diagram 3 : The short-circuit current I_K is about 5 kA. A comparison with the previous calculation confirms satisfactory agreement.

Rule of thumb for quick estimation

A prospective short-circuit current of 50 kA at the secondary terminals of a transformer at 400 V, will be limited to about 10 kA at the end of a connecting lead with a length of 10 m and cross-section of 10 mm². If the same feeder has a cross-section of 25 mm², the length of the wire is to be 25 m for reducing the current down to 10 kA.

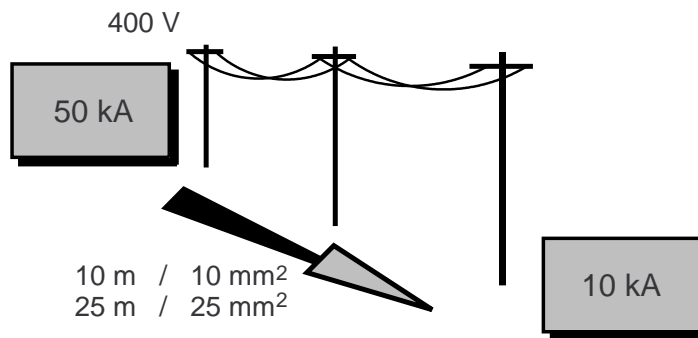

Fig. 2.2-11: Rule of thumb for a quick estimation of the short-circuit current at the end of a feeder.

Specimen example

1)	Transformer $P_{Tr} = 630 \text{ kVA}$ $U_k = 6 \%$ $U = 400 \text{ V}$	R/mΩ	X/mΩ
		3.1	13.5
2)			
3)	Cable 35 m 50 mm ²	12.5	2.5
4)	Cable 20 m 25 mm ²	14.1	1.5
5)	Cable 15 m 2.5 mm ²	110.0	1.1
		Σ 139.6	18.6

Fig. 2.2-12: Arrangement of a section of an installation.

Short-circuit at the point 5 :

According to the above mentioned formula

$$Z = \sqrt{R^2 + X^2} = \sqrt{(139.6\text{m}\Omega)^2 + (18.6\text{m}\Omega)^2} = 140.8\text{m}\Omega$$

$$I_{k''} = \frac{U_{\text{NTrafo}}}{\sqrt{3} \cdot Z} = \frac{400\text{V}}{\sqrt{3} \cdot 140.8\text{m}\Omega} = 1.64\text{kA}$$

The value calculated above is rather conservative and includes a factor of safety as other sources of current reduction like the arc voltage, the contact resistance and the internal resistances of the different devices in the path of the short-circuit were not considered.

2.2.5. Dynamic stress on the connecting leads in the case of a short-circuit

Each current carrying conductor induces a circular magnetic field around it. Parallel current carrying conductors, depending on the direction of the flow of the current, produce an attracting or repelling electro-magnetic force between them. This force increases with increasing current and reduced distance between the conductors.

The relation between the above mentioned factors which is useful for the panel builders is represented below :

$$F_H = \frac{\mu_0}{2\pi} \cdot I_S^2 \cdot \frac{L}{a} = 0.2 \cdot 10^{-6} \cdot I_S^2 \cdot \frac{L}{a}$$

- F_H : Electro-magnetic force between the conductors [N] (9.81N=1kg)
- μ_0 : Absolute permeability (of air) $\left[4\pi \cdot 10^{-7} \frac{\text{Vs}}{\text{Am}}\right]$
- I_S : Peak value of the short-circuit current flowing in the conductor [A]
- L : Spacing of the conductor supports [m]
- a : Distance between the centres of the conductors [m]

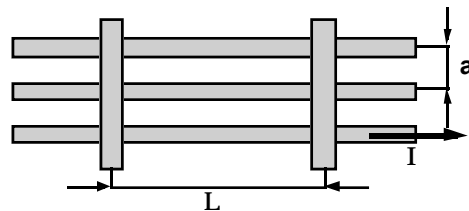

Fig.2.2-13: 1 A schematic view of parallel bus-bars

Case 1 : Without short-circuit protective device

Short-circuit current : 50 kA r.m.s. symmetrical $I = 50 \text{ kA}_{\text{eff}}$ ($\hat{I}_S = 71 \text{ kA}$)

Distance between the centres of the conductors $a = 0.1 \text{ m}$

Spacing of the conductor supports $L = 1 \text{ m}$

$$F_{\text{Abstoss}} = 0.2 \cdot I_s^2 \cdot \frac{L}{a} = 0.2 \cdot (71 \text{ kA})^2 \cdot \frac{1 \text{ m}}{0.1 \text{ m}} = 10'082 \text{ N}$$

The repelling force is roughly equivalent to the force of attraction due to the gravity of the earth on a mass of 1 tonne.

Case 2 : With current limiting circuit breaker

Prospective short-circuit current $I = 50 \text{ kA}_{\text{eff}}$ r.m.s. symmetrical.

Let-through current of the 140M approx. $I = 10 \text{ kA}_{\text{eff}}$ ($\hat{I}_S = 14 \text{ kA}$)

Distance between the centres of the conductors $a = 0.1 \text{ m}$

Spacing of the conductor supports $L = 1 \text{ m}$

$$F_{\text{Abstoss}} = 0.2 \cdot I_s^2 \cdot \frac{l}{a} = 0.2 \cdot (14 \text{ kA})^2 \cdot \frac{1 \text{ m}}{0.1 \text{ m}} = 392 \text{ N}$$

This is about the force of gravity on a mass of 40kg.

What we learn from the calculations:

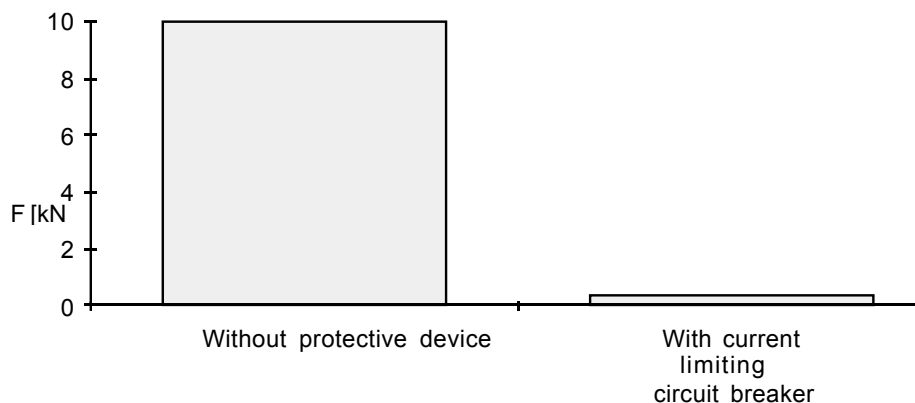

Fig. 2.2-14: With the help of a quick acting, current limiting circuit breaker, the let-through energy and with it the electro-dynamic forces due to short-circuit current acting on the various parts of the installations are drastically reduced. In the above example under the given conditions, the mechanical stress on the bus-bar supports is reduced by a factor of almost 26 by using a quick acting, current limiting circuit breaker. Whether 1 Tonne per running meter of bus-bar is to be supported or only 40kg, makes quite a difference in the design of the panels. This

means that larger spacing between the supports of the bus-bars would be possible. This leads to a simplification of the design of the panel and means significant cost-saving for the panel builders.

2.3. Short-circuit protection

The two kinds of releases, the over-current or the short-circuit release, differ basically on the magnitude of the current or the energy which has to be interrupted. In the case of an overload, it is only 1.15 to about 16 times the rated current of the device, whereas in the case of a short-circuit, the magnitude of the prospective short-circuit current could be a few tens of kA that has to be brought under control. Correct and reliable short-circuit protection means that the device should be able to handle currents of the order of 1000 times or even 10000 times the rated current.

Circuit breakers without current limiting feature (current-zero interrupting type) will let practically the whole energy due to a short-circuit with its full destructive power through the device. The current limiting circuit breakers will limit the energy already during its build-up and will interrupt the current rapidly.

2.3.1. The principle of current limitation

Unlike the current-zero interrupting type, the current limiting type of circuit breakers have the following features :

- Quick opening of the main contacts.
- Guiding the arc rapidly away from the contacts to the arcing chamber
- Quenching the arc

The principle of current limitation in the case of fuses is also applied to the current limiting circuit breakers. The current circuit must be quickly interrupted, a high arc voltage is to be produced and the heat energy is to be drawn away from the arc. Because of the energy generated in the protective device in the case of a short-circuit, the clearing time plays a deciding role. Lowest possible let-through values are especially important for circuit breakers used in branch circuits for motor starters.

Opening of the contacts

A key component of a well designed circuit breaker is the quick acting contact system.

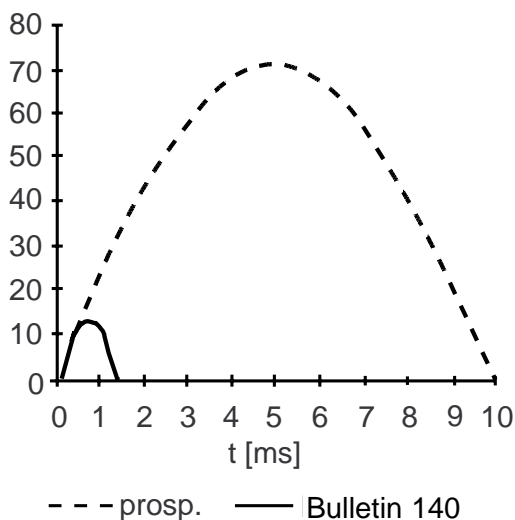

Fig. 2.3-1: Current form during a breaking operation of the circuit breaker 140M. The prospective short-circuit current (50 kA symmetrical r.m.s. value as illustrated) must be quickly interrupted so that it may not reach the maximum value (current limitation).

In the symmetrical case, the rapidly rising prospective short-circuit current which reaches the theoretical peak value already after 5 ms must be interrupted quickly. The contacts must be opened practically without any time delay during the rising stage of the current. A part of the repelling force necessary for opening the contacts comes from the electro-dynamic force induced by parallel current carrying paths with appropriate geometrical form and direction of current flow and the other part from the current constriction of the contact tips.

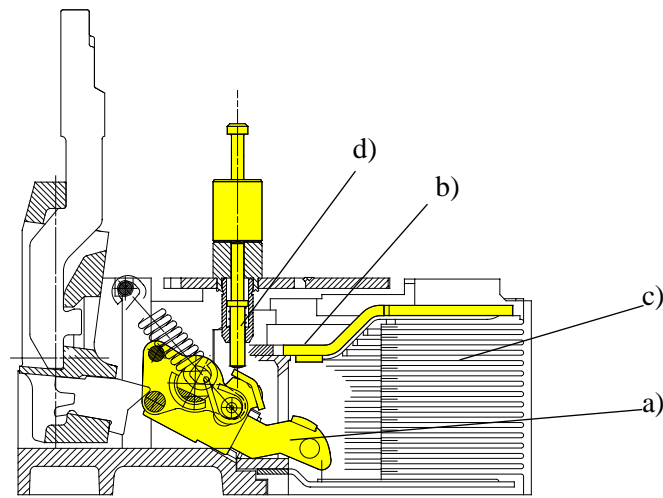

Fig. 2.3-2: Principle of the contact system 140-CMN

a) Moving contact or the contact bridge, b) Stationary contact, the front-half, c) Arcing chamber d) Magnetic striker

In the case of very quick-acting, current limiting circuit breakers, the major factor behind the opening of the contacts is the magnetic striker. The induced force must overcome the force of the retaining springs, strike the contact and accelerate it against the high contact spring force. An arc is struck between the stationary and the moving contacts, which is rapidly driven away towards the arcing chamber. The moving contact opens fully, strikes the end buffer, bumps back and starts its return journey, accelerated additionally by the compressed contact spring force. To prevent a re-closing of the contacts, the release mechanism of the mechanical tripping device must be activated by the striker early enough so that it may react timely to latch the moving contact and keep the contacts permanently open.

As for example, in the case of the 140-CMN, the striker hits the contact only after 0.7 ms and the total clearing time is about 1.5 ... 1.8 ms (in comparison, the half-cycle time of a 50Hz sinusoidal current wave is 10 ms). In other words, the short-circuit current is interrupted long before it could reach its prospective peak value. The result of this very rapid interruption is a highly effective current limitation.

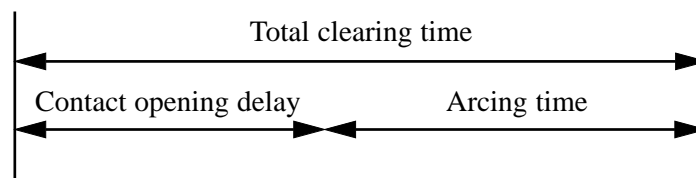

Fig.2.3-3: The total clearing time consists of:

- *Contact opening delay*
- *The time for the arc to travel from the contact tips to the arcing chamber and get extinguished through splitting and cooling.*

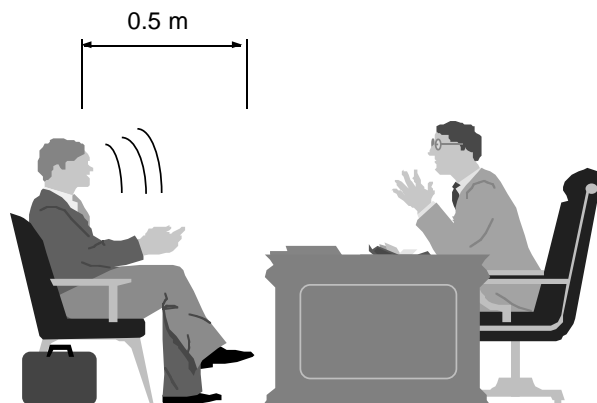

Fig. 2.3-4: During the clearing time of 1.5 ms, the sound wave travels a distance of just half a meter between two conversing persons (velocity of sound in air 330 m/s). The circuit breaker is a purely electro-mechanical device.

To meet the requirements of the high current limiting features of a circuit breaker, complicated and time consuming optimisation of the time/travel characteristic and reduction of the mass-inertia of the moving system is necessary. The movement of the operating mechanism is to be analysed to the last detail and an optimally dimensioned magnetic striker is to be designed. One method is with the help of finite elements.

Quenching of the arc

The number of part-arcs, which are ultimately connected in series in the current path during the interruption of a short-circuit are different for a single-break or a double-break construction.

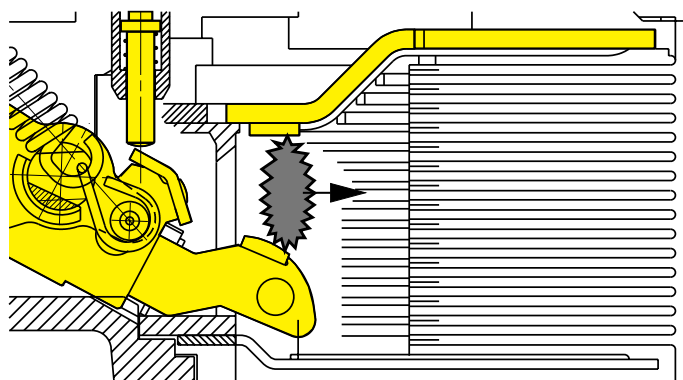

Fig. 2.3-5: Fork type moving contact with arcing chamber
View from one side of the double-break contact system with two separate arcing chambers (one for each contact tip). The result is high arc voltage and efficient current limitation.

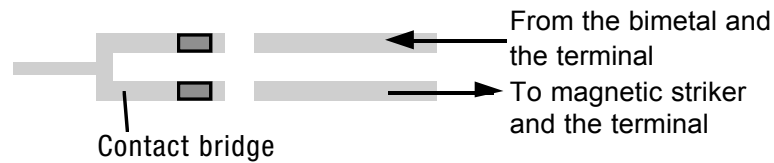

Fig. 2.3-6: The principle of the fork type moving contact

The circuit breaker 140-CMN is provided with a double-break moving contact in its current path. The Y-shaped bridge strikes two arcs as it opens. This means that two resistances in series are connected in the path of the short-circuit current. By connecting two arc-paths in series, the sum of the arc voltage is increased and with it the breaking capacity and the efficiency of the current limitation of the circuit breaker which depend on the arc voltage.

The arc voltage increases with the number of splitter (de-ion) plates. Each part-arc between the neighbouring splitter plates are added to one another (series circuit). Circuit breakers with a high short-circuit breaking capacity at supply voltages above 400 V, values of about 600 ... 700 V are usual. This arc voltage opposes the supply voltage.

An arcing chamber with a fixed number of splitter plates will always produce the same arc voltage. For this reason, a circuit breaker optimised for a voltage of 400 V may have a reduced breaking capacity at 690 V. At 690 V, the opposing arc voltage is lower in relation to the supply voltage and hence the breaking capacity and the current limitation is also reduced.

The temperature of the core of an arc may be of the order of 10000 ... 15000 °K (the contact material melts at about 1300 °K). To avoid damage, the arc must be quickly blown to the arcing chamber, elongated, divided in part-arcs between the splitter-plates and cooled. The electromagnetic force for driving the arc towards the arcing chamber comes from the specially shaped stationary and moving contacts. Without this blowing field, the arc will go on burning between the silver alloy contact tips and destroy the circuit breaker.

During the breaking process, typical value of the pressure inside the arcing chamber would be of the order of 13 ... 15 bar.

The volume of the arcing chamber and the mass of the splitter plates must be designed in such a way that they are capable of absorbing the enormous energy generated by the arc (the arcing chamber will be heated by an energy equivalent to about 2 Megawatt power flowing for a fraction of a second). The classical conflict between the high breaking capacity and the compact size of the arcing chamber, and with it the overall dimension of the device itself, must be solved and the best compromise accepted.

Faster is the interruption, less is the energy which the circuit breaker has to handle and more compact is the design. Only in this way circuit breakers with small overall dimensions can be constructed.

Internal impedances / self protection

For the calculation of the short-circuit current at any point of the installation, the resistances and inductances of the connecting leads are considered for the reduction of the actual short-circuit current. The internal impedance of the circuit breaker itself also helps to reduce the current further.

The resistance of the current path with the heater of the bimetal strip and the coil of the instantaneous magnetic trip in the circuit is relatively high for circuit breakers in the lower current ranges (approximately $< 20\text{A}$). It could be so high as to reduce any possible prospective short-circuit current to a value low enough so that the breaker can handle it thermally and can also interrupt it without any mechanical damage to itself due to electro-dynamic forces. In other words, the circuit breaker is self protecting, with practically unlimited breaking capacity. It can be installed in any part of the installation, even at points where very high prospective short-circuit currents are expected. The current range up to which a circuit breaker is self protecting depends on the breaking capacity of the breaker. As this again depends on the supply voltage, the range up to which self protection is assured is different for different supply voltages.

For selecting a circuit breaker for short-circuit protection, the first point to be checked is whether it is self protected or not. If it is self protected, any further calculation or estimation of the short-circuit currents which may flow in the installation is superfluous.

Independent of its point of installation, self protecting circuit breakers do not need any back-up fuse. Hence, the circuit breaker can be installed at a point without any back-up fuse where the prospective short-circuit current may reach very high values.

The connecting wire up to the terminals of the circuit breaker must, however, be protected by fuse. The largest size of the fuse can be chosen here, depending only on the cross-section and the length of the connecting wire.

Let-through values

The figures which reflect the quality of the short-circuit protection are the let-through values. The magnitude of the let-through (cut-off) current and the Joule-Integral (also called the let-through energy or the i^2t -value) as a function of the prospective short-circuit current supply information over the current limiting capability of the circuit breaker. They indicate the limits of the electro-dynamic stress which the downstream contactors or other devices have to withstand in the case of a short-circuit. The let-through values actually decide the sizes of the various devices connected downstream of the circuit breaker. Other constructional and design features like the distances between the supports of the bus bars for the necessary short-circuit withstand capacity also depend on the let-through values.

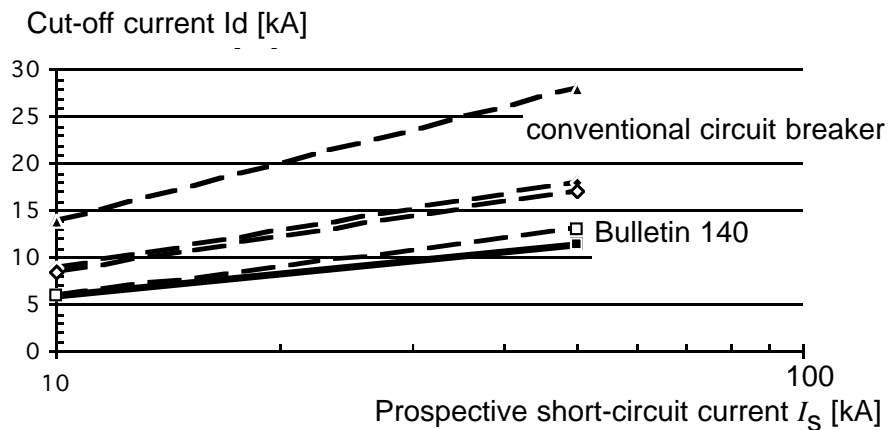

Fig. 2.3-7: The cut-off current characteristic of the circuit breaker 140-CMN 63A compared to a conventional circuit breaker.

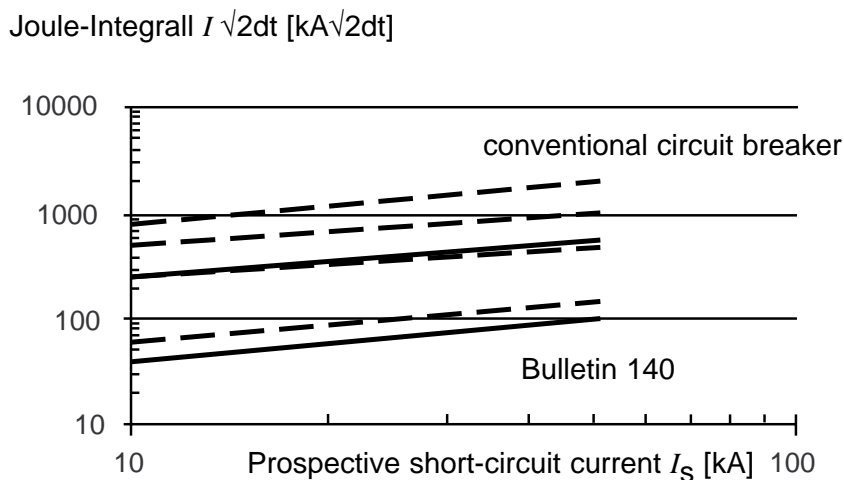

Fig. 2.3-8: The Joule-Integral characteristic of the circuit breaker 140-CMN 63A compared to a conventional circuit breaker.

Hence, if one would like to compare the various brands of circuit breakers with one another, it is not sufficient to compare only the accessories, mounting and handling features and the overall dimensions but most important of all, the protective qualities of the devices are to be compared. Which circuit breaker has the lowest let-through values ?

The Allen-Bradley current limiting circuit breaker of Rockwell Automation has low let-through values. The electrical and thermal stresses on the downstream devices and installations are low and the circuit breaker assures reliable protection in the case of a short-circuit. The co-ordination type "2" in accordance with the IEC 947-4-1 (no or easily separable welding of contacts) is thus possible with the same rating of contactors as that of the current setting of the circuit breaker i.e. without over-dimensioning of the contactors (with the circuit breaker 140M and 140-CMN).

Definition of I^2t :

The Joule-Integral, also called the I^2t or the let-through energy is the integral of the square of the let-through current over time. ($I^2t = \int_{t_0}^{t_1} i^2 dt$)

It is obvious from the formula, that short clearing time and low cut-off current, low because of the high arc voltage, will keep the Joule-Integral also low.

Definition of I_d :

Under the expression cut-off (let-through) current I_d , the peak value of the current which passes through the circuit breaker during the interruption of a short-circuit is understood. A low value of the cut-off current is achieved by attaining a high arc voltage with a rapid rate of rise.

2.3.2. Breaking capacity

The symmetrical r.m.s. value of the current with a given power factor ($\cos \phi$) and at a given voltage which a switching device or a fuse can reliably and safely break (interrupt) under specified conditions is called the breaking capacity.

The breaking capacity of a current limiting circuit breaker depends mainly on the rise-time and the magnitude of the arc voltage and the design of the contact system including the arcing chamber. In other words, it is defined by the construction of the device.

If the prospective short-circuit current exceeds the breaking capacity of the circuit breaker, the clearing time could be just longer than the duration in milliseconds, which the breaker can with-stand thermally and electro-dynamically. If the arc is not extinguished rapidly enough, the over-heating caused by it may lead to the destruction of the circuit breaker.

The standard IEC 947-2 differentiates between the rated ultimate short-circuit breaking capacity I_{cu} and the rated service short-circuit breaking capacity I_{cs} :

- Rated ultimate short-circuit breaking capacity I_{cu} (similar to the utilisation category P1 of the earlier standard) :
Switching sequence O-t-CO. Reduced functional capability, certain alteration of the time/current characteristic is tolerated, higher temperature-rise acceptable.
- Rated service short-circuit breaking capacity I_{cs} (similar to the utilisation category P2 of the earlier standard) :

Switching sequence O-t-CO-t-CO. No reduction in functional capability is accepted.

- O: Breaking operation, with the contacts closed before the initiation of the short-circuit.
- t: Time interval
- CO: Switching on to a short-circuit with immediate breaking operation.

In electrical installations, 90 % of all circuit breakers are selected on the basis of I_{cu} . The selection on the basis of I_{cs} is, however, showing an upward trend.

2.3.3. Electrical life (durability) of circuit breakers

Test requirements

According to the IEC 947-2, there is actually no defined stipulation regarding the requirements of electrical life of a circuit breaker. The numbers of switching

operations which a circuit breaker under no-load, normal load, overload and short-circuit conditions has to make and/or break are stipulated. These numbers vary between two switchings (O-t-CO) for the rated ultimate short-circuit breaking capacity test and a few thousand purely mechanical operations under no-load condition.

Practical aspect

The electrical life or durability (life of the contact tips) of a circuit breaker, similar to a contactor, depends mainly on the magnitude of the breaking current (neglecting the contact erosion due to bouncing during the making operation, which is kept at a minimum with appropriate constructive measures).

Lower currents in the range of normal service conditions or overloads in the range of the thermally delayed release mechanism has very little influence on the contact life in comparison with the effect of the short-circuit currents of the order of the breaking capacity. Due to a few high current short-circuits close to the bus bars, the electrical erosion of the contacts could be so high that the circuit breaker may have to be replaced. However, practical experience shows that the magnitude of the short-circuit currents would be rarely of the order of 50 kA or higher. They usually lie much lower in their amplitudes and the contact erosion is also within reasons.

In the case of a circuit breaker which is already installed, it is not easily visible from outside how many short-circuits it has already interrupted or what the actual amplitudes of the short-circuit currents were and whether the circuit breaker has already reached the end of its electrical life.

In spite of the above, the circuit breaker indicates indirectly when it has reached the end of its useful life. The thermal overload release tends to trip earlier, already at the rated value of the current setting on the scale. Thus the protective function of the device remains fully active right up to the end of its life.

The reason of the early tripping is because of the higher temperature-rise of the current path already at the rated current due to the increased contact resistance of the strongly eroded main contacts. In the long run, it affects the tripping characteristic of the thermal release. Early tripping is the result.

A circuit breaker which can no longer continuously carry its normal rated current indicates that the contact resistance is too high (electrically eroded contacts). They have reached the end of their electrical life and are to be replaced.

In other words, the circuit breaker remains reliable and safe up to the end. A normal operation indicates that the circuit breaker is functionally in order. If there is no early tripping after the breaker is switched on, it signifies that it can interrupt a short-circuit as well.

2.4. Short-circuit coordination

The principal task of a short-circuit protective device (SCPD) is to quickly recognise, limit and interrupt a high current due to a fault and keep the damage at the location of short-circuit within admissible limits.

To avoid unacceptable damages or stress during the interruption of a short-circuit on the devices connected downstream of the circuit breaker, a mutual matching or "co-ordination" of the starter components like contactor and circuit breaker is necessary. The short-circuit co-ordination between the switching and the protective devices takes care of all the electro-physical effects on all the components affected by the short-circuit.

2.4.1. Definitions in accordance with the IEC 947-4-1

Type of coordination "1"

- Under short-circuit conditions, the contactor or starter shall cause no danger to persons or installations.
- The contactor or starter may not be suitable for further service without repair and replacement of parts.
- Damage to the contactor and to the overload relay is accepted.

Type of coordination "2"

- Under short-circuit conditions, the contactor or starter shall cause no danger to persons or installations.
- The contactor or starter shall be suitable for further service.
- No damage to the contactor and to the overload relay is accepted. The risk of contact welding is recognised, in which case the manufacturer shall indicate the measures to be taken as regards the maintenance of the equipment. (The usual interpretation is if the contacts can be separated without unacceptable deformation with the help of a simple tool like a screw-driver, the conditions of type "2" is fulfilled).

2.4.2. Conclusions drawn from the definitions for the user

A short-circuit always means an interruption of the service. If the types of short-circuit co-ordination are analysed from the practical points of view of the user, the following conclusions may be drawn :

- **Type of co-ordination "1"**

The contactors and overload relays must be replaced after a short-circuit. Longer interruption of service and the resulting loss of production time together with the higher volume of replacement material increase the running cost of the load feeders. The individual drives as for example for machine tools or processing machines which are not parts of an elaborate system, the additional expenses may remain within acceptable limits and the type of co-ordination "1" could be good enough. The continuity of service is anyway interrupted after the short-circuit.

For more complex production processes is the type of co-ordination "1" less suitable. Redundant reserve components for each starter used in the installation must be readily available at the site so that the load feeder could be returned back to service without unnecessary delay.

If the actual short-circuit current is lower than the test value of the conditional short-circuit current on the basis of which the combination was selected for the type "1" co-ordination, a continuation of the service may be possible. However, the verification of the suitability for further service is not at all simple.

- **Type of co-ordination "2"**

Starters selected to fulfil the type of co-ordination "2" are suitable for further service immediately after the fault without replacement of parts. A short-circuit tends to reduce the electrical life of the contactors and the circuit breakers (due to the high temperature of the contact tips and the strong magnetic field due to the short-circuit current, molten contact material is blown out and splashed inside the arcing chamber). Depending on the frequency of operations per hour of the contactor, it may be necessary to replace it earlier than originally planned. This can, however, be postponed and carried out at a more convenient time, as for example during the next planned maintenance period.

Type of co-ordination "2" is to be recommended where due to complex manufacturing processes the production-stop time is too costly, it is highly expensive to re-start the plant after a longer still-stand period or where a service interruption may lead to dangerous situations if continued over a certain period. It is not usually necessary to keep a large volume of replacement material in stock.

If the actual present day requirements of the type of co-ordination "2" is further extended to include the additional condition that it should guarantee a certain

electrical life of the switching device after the short-circuit has occurred, we have another more severe type of co-ordination. A stipulated number of switching operations of the starter after the interruption of the short-circuit is to be assured (reliable function up to a defined date, as for example the yearly maintenance). This type of co-ordination is under discussion and may be included in the standard IEC 947-4-1 in future.

2.4.3. Physical significance of the short-circuit co-ordination

The short-circuit affects not only the circuit breaker. It is rather the combination of circuit breaker and contactor which together has to bring the short-circuit under control. It is the contact system of the contactor which is actually involved. After a short-circuit and for the type of co-ordination "2", the contacts of the contactors must not be so strongly welded that they can not be easily separated. Depending on the magnitude of the short-circuit current, there are three typical regions.

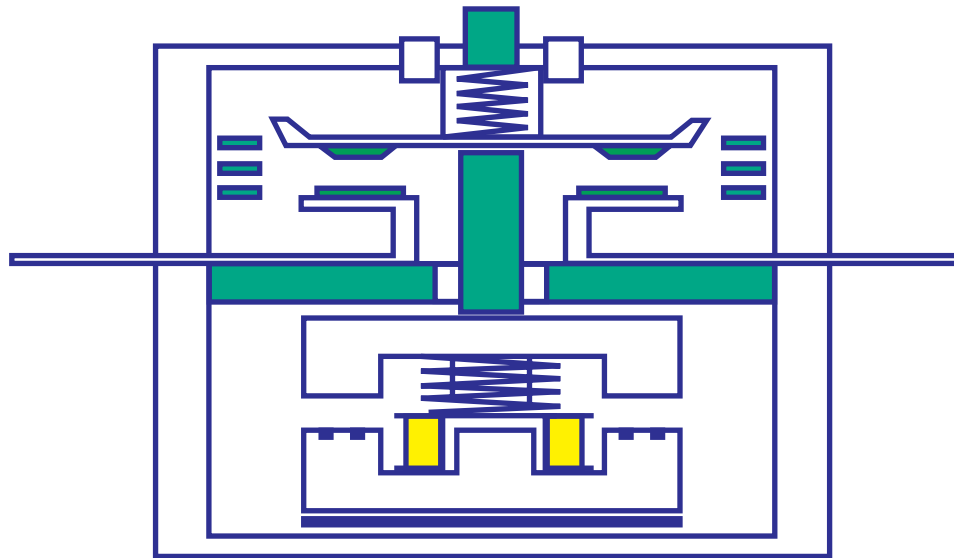

Fig. 2.4-1: Schematic representation of a contactor. The welding of the contacts of the contactor depends on the construction and design of the contact system.

The three critical regions are (status: on load, contactor closed) :

- A relatively low short-circuit current flowing for a certain length of time may warm up the contacts of a contactor in such a way that the melting temperature of the contact material may be attained and part of the contact tips may melt. After the interruption of the short-circuit, the contact tips cool down and solidify but now with both the contact halves bonded together. The contacts are welded.

- An impulse of a short-circuit current of a medium magnitude causes a short lifting (throw-off) of the moving contact away from the stationary contact due to the electro-magnetic repulsive force induced by the current passing through the contacts.

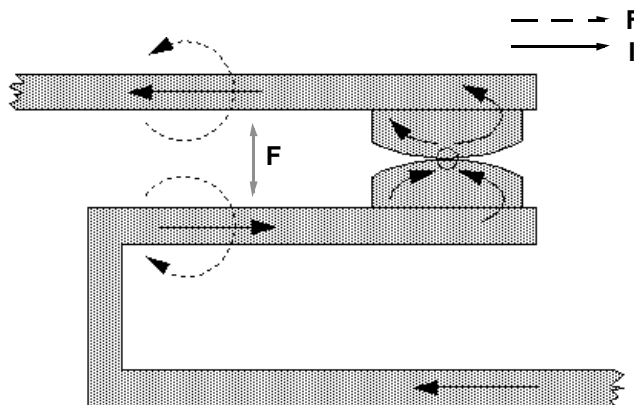

Fig. 2.4-2: Lifting or throw-off force induced in the contactor contacts

Two conductors, parallel and close to one another, carrying current in the opposite directions, induce a repulsive electro-magnetic force in them. The value of this repulsive force, especially induced in the contact tips, flat in form and lying very close to one another, may reach such a magnitude due to the flow of the short-circuit current that the contacts may lift (be thrown off) for a short period of time (lifting force due to the current constriction).

As soon as the contacts are thrown-off, an arc is struck between the contacts which heats up the contact material and may melt part of it. As the contact bridge returns back after the interruption of the short-circuit current, it lands on the still liquid pool of molten metal. A sort of spot-welding may occur.

- Very high magnitude of the prospective short-circuit current, say 50 kA, induces such a strong repulsive force in the contacts that the contact bridge practically fly away from the stationary contact and may reach and bounce back from the end buffers. The arc burning between the rapidly opening contacts will partly vaporise appreciable amount of the contact material, and due to the presence of the strong magnetic field, splash it towards the arcing chamber. In the meanwhile, the arc will be quenched and the short-circuit current will be broken by the quick acting current limiting circuit breaker or the fuse. As the contact bridge, at the end of its trajectory or bounced back from the end buffer, accelerated by the contact spring force lands back on the stationary contact, the contact tips are in most of the cases back to solid form. There is no liquid pool of material on the tips and the risk of welding of contacts is a minimum (with quick acting current limiting circuit breakers as SCPD).

Hence, we see that the short-circuit current of a medium magnitude is critical for the contactor. The exact limits of the region of the critical short-circuit current depend on the size, design and construction of the contact system.

The committee responsible for the standards recognised exactly this problem and introduced a test current called "r"-current for the verification of the types of short-circuit co-ordination. The value of this current depends on the size of the contactor.

The critical prospective short-circuit current "r" for the verification of the short-circuit co-ordination for a 16 A contactor in accordance with the IEC 947-4-1 is only 1 kA. Only for larger contactors with rated operational currents above 630 A, the "r" current would be 30 kA or higher.

Table Fig. 2.4-3 Prospective short-circuit test current as a function of the rated operational currents.

Rated operational currents I_e (AC-3) [A]	Prospective short-circuit test currents "r" [kA]
$0 < I_e \leq 16$	1
$16 < I_e \leq 63$	3
$63 < I_e \leq 125$	5
$125 < I_e \leq 315$	10
$315 < I_e \leq 630$	18
$630 < I_e \leq 1000$	30
$1000 < I_e \leq 1600$	42
$1600 < I_e$	To be agreed upon between the user and the manufacturer

This is also exactly the magnitude of the short-circuit current encountered most-frequently in the practice. The impedance of the connecting wires and also the impedance at the location of the short-circuit (not a dead short-circuit) limits the theoretical high magnitudes of the prospective short-circuit currents to a value between 1 and 20 kA only.

Circuit breakers, which quickly recognise and reliably interrupt the frequently occurring short-circuit currents of relatively lower magnitude are to be favoured for short-circuit co-ordination (require smaller size of contactors).

2.4.4. Requirements of a circuit breaker for a simple co-ordination of type "2"

The circuit breaker must be quick acting and must effectively limit the short-circuit current during the process of breaking. The rise of the high short-circuit current must be hindered already during its initiation. The values of the cut-off current and the Joule-Integral which the circuit breaker lets through during a short-circuit must not be so high as to weld the contacts of the contactor. Neither should it damage the thermal overload release so that it permanently alters its time/current characteristic and lie outside the acceptable band of tolerance (type "1").

To achieve an economic and space-saving combination conforming to the type "2" with a circuit breaker, the contactor should have the same current rating as the circuit breaker or may have to be slightly over-dimensioned (in the case of circuit breakers with no or not so efficient current limitation, contactors are to be over-dimensioned as a rule).

With the Allen-Bradley circuit breaker 140 of Rockwell Automation, this is possible. This circuit breaker, the development of which is based on a profound knowledge of material science and an in-depth know-how in the field of electro-mechanics, permits to realise starter combinations in accordance with the type "2"

- practically always without over-dimensioning of the size of the contactor .
- without following time consuming and complicated guidance or references to co-ordination tables.

The simple realisation of starter combinations made up of standard components, meeting the requirements of the co-ordination type "2", which may consequently replace the fuses in motor branch circuits has now been achieved.

Circuit Breaker

3. Fields of application of circuit breakers

3.1. General procedure for the selection of correctly rated circuit breakers

The general procedure for the selection of correctly rated circuit breakers follows the following scheme :

- **What is the task of the branch circuit or feeder ?**
Will it be used for the protection of connecting leads, protection of installation, group-protection or motor protection? Select the appropriate circuit breaker type, with or without the thermal overload protection. Decide which type of protective characteristic (cable or motor protection).
- **Which rated current / setting range ?**
Do the setting ranges of the thermal and the magnetic release cover the requirements of the particular application (protection of transformer or generator) ?
The setting ranges of the various sizes of circuit breakers are overlapping. The same current settings may be partly covered by more than one size of circuit breakers (as for example 80 A setting is covered by both the sizes 140-CMN and 140M-K5F). The following features depend on the size of the circuit breakers : accessories (as for example types and numbers of auxiliary contacts), mode of operation (toggle or rotating handle), mode of mounting (snap-on or screw mounting) or the electrical characteristics (breaking capacity, selectivity etc.).
- **Breaking/making capacities / rated operational voltage?**
Where is the point of installation of the circuit breaker ? What is the expected magnitude of the prospective short-circuit current at that location ? Is a lower making/breaking capacity acceptable (appreciable reduction of the short-circuit current due to long connecting leads or due to other short circuit protective devices connected upstream) ? Is the breaking capacity reduced due to higher rated operational voltage (as for example >400 V) ? Does it indicate a selection on the basis of I_{cu} (rated ultimate short-circuit breaking capacity, reduced functional capability after the interruption of a short-circuit) or on the basis of I_{cs} (rated service short-circuit breaking capacity, full functional capability after the interruption of the short-circuit) ? With the help of an efficient group-protection, can smaller and less expensive circuit breakers be utilised ?

- **Any special requirements?**
Must reduction factors for the rated current be taken into account due to :
ambient air temperature ($> 40...60^\circ$), altitude of the site of installation (>2000 m above m.s.l), higher supply frequency (>400 Hz) ?
- **Which type of co-ordination?**
Selection of the downstream contactor in accordance with the type of co-ordination type "1" or type "2" ?
- **What is the mode of mounting?**
Deciding factor for the supporting/adapter plates of the modular mounting system Bulletin 140 (suitability for the selected type of circuit breaker).
- **Cross-section of the connecting wire/cable?**
The cross-section of the connecting leads to the motors are to be selected on the basis of the current setting of the thermal overload release of the circuit breaker. Eventually, the maximum permissible length of the connection is to be considered (shock hazard due to touch potential in the case of a short-circuit).

3.2. Circuit breakers for motor protection

Continuous overload current leads to unacceptable temperature-rise, accelerated ageing of the insulating material, increased wear and ultimately faulty operation of the connected equipment.

Similar to a bimetallic thermal overload relay, a circuit breaker is suitable for :

- Starting and running under normal service conditions of
 - low voltage motors from 0.02 to ...kW.

With additional devices also for :

- Special starting and running conditions such as :
 - Motors in intermittent periodic duty or with fluctuating load
 - Soft starter (protection of motors with phase controlled soft starting).
 - Frequency converter (speed control of three phase motors).

3.2.1. Protection of motors with direct-on-line starting

A normal three-phase motor is sufficiently protected by the combination of a contactor and a circuit breaker with motor protective characteristic. As the full rated current of the motor flows through the circuit breaker, the current setting of the thermal release is equal to the motor rated current

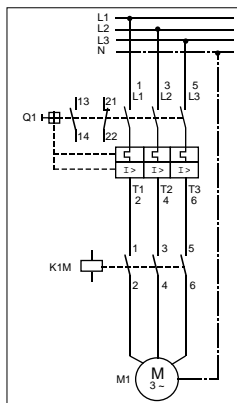

Fig. 3.2-1: Starter for direct-on-line starting with circuit breaker

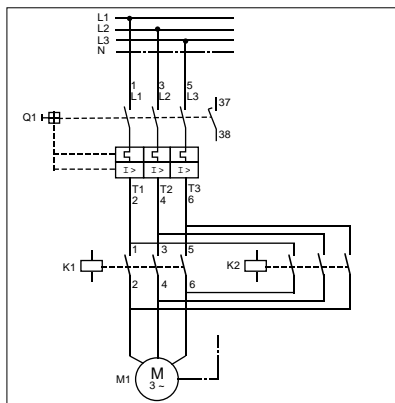

Fig. 3.2-2: Reversing starter with circuit breaker

3.2.2. Protection of motors with star-delta starting

With one circuit breaker

In the case of a star-delta starter, the upstream circuit breaker takes over the motor protective function and the two thermal overloads connected in series with the motor windings become superfluous. The cross-section of the connecting leads to the motor must be selected on the basis of the rated current of the overload protective device (current setting of the circuit breaker). Because of the circuit breaker, a smaller cross-section of the connecting wire may be taken than in the case of a fuse together with a single thermal overload relay in the motor winding circuit (over-dimensioning of the fuse is necessary to cope with the high starting current of the motors).

The current setting of the thermal release of the circuit breaker is equal to the actual rated current of the motor. The calculation of the rated current for the setting of the current scale with the help of the factor $\sqrt{3}$ ($=1,73$) is no longer necessary.

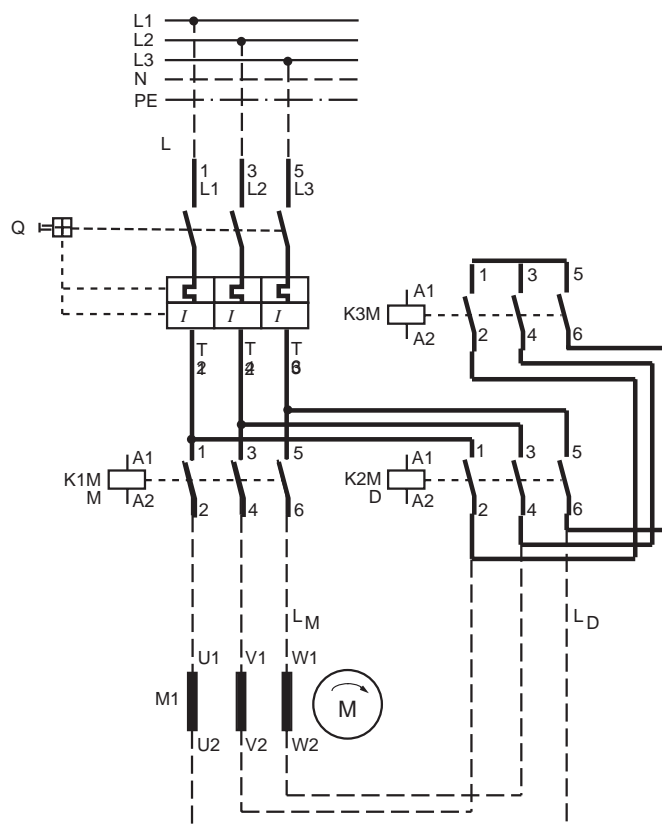

Fig. 3.2-3: Starter for star-delta starting with one circuit breaker

Circuit Breaker

For economical reasons, it is justifiable to use even two thermal overload relays in the motor winding circuits to realise a further reduction of the cross-section of the motor connecting leads. The current setting of the thermal overload relays would be 0.58 times the motor rated current whereas the setting of the current dial of the circuit breaker would be 1.2 times the motor rated current. Unnecessary premature nuisance trippings of the circuit breaker is thus avoided.

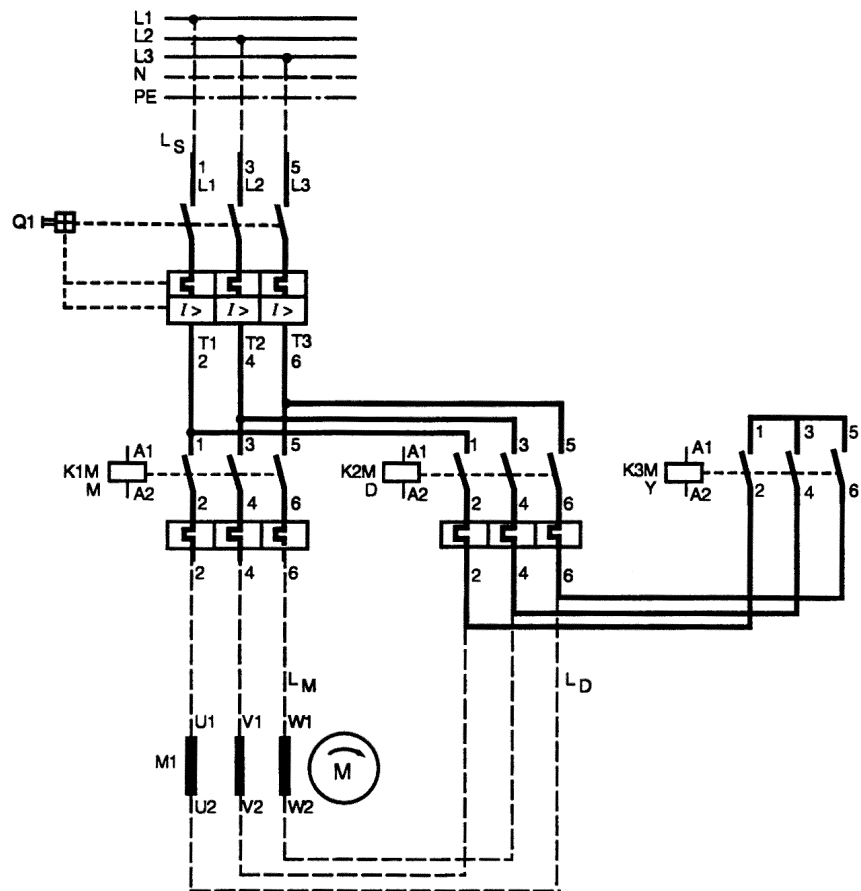

Fig. 3.2-4: Starter for star-delta starting with one circuit breaker and two thermal overload relays

With one circuit breaker and one thermal overload relay

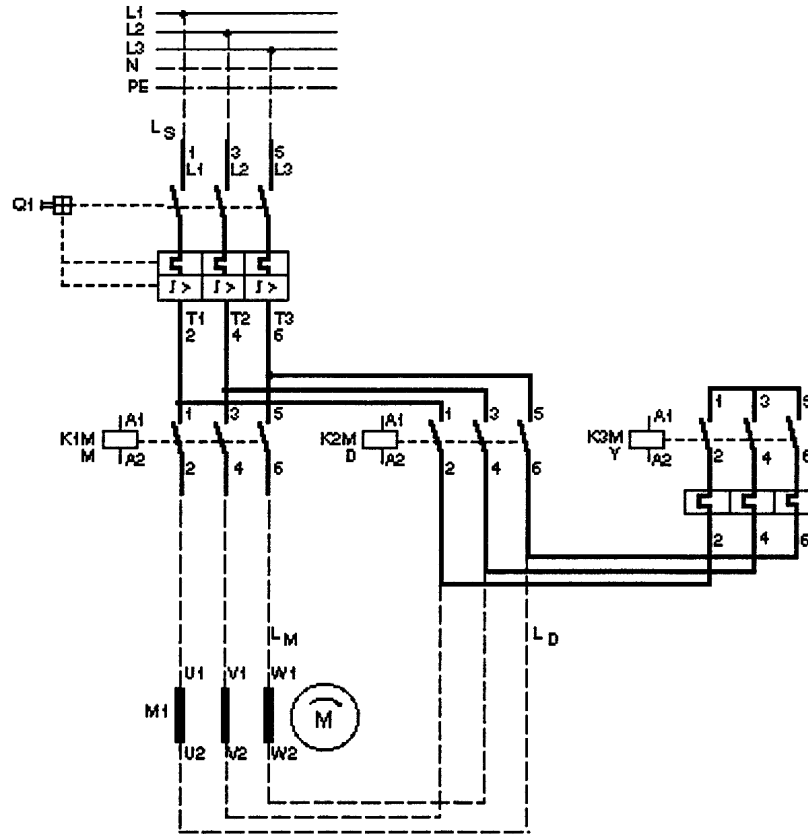

Fig. 3.2-5: Starter for star-delta starting with one circuit breaker and one additional thermal overload relay in series with the star-contactor during the running-up phase.

During the period when the starter is connected in star, a current equal to $\frac{1}{3} \cdot I_e$ flows through the circuit breaker. The current setting of the circuit breaker is, however, equal to I_e . If the rotor is locked during the starting, a current of about $6 \cdot \frac{1}{3} \cdot I_e = 2 \cdot I_e$ may flow through the circuit breaker. Thus, the circuit breaker will trip with a relatively long time delay in the case of locked-rotor during starting for a starter connected in star and provide insufficient protection.

An additional thermal overload relay connected in series with the star-contactor takes over the protective function during the running-up phase of the motor. The maximum current setting of this relay should be equal to the phase current in delta-connection ($0.58 \times I_e$).

With two circuit breakers

A star-delta starter with two circuit breakers permits a reduction in the cross-section of the motor connecting leads and is suitable for heavy-duty starting with relatively long running-up time.

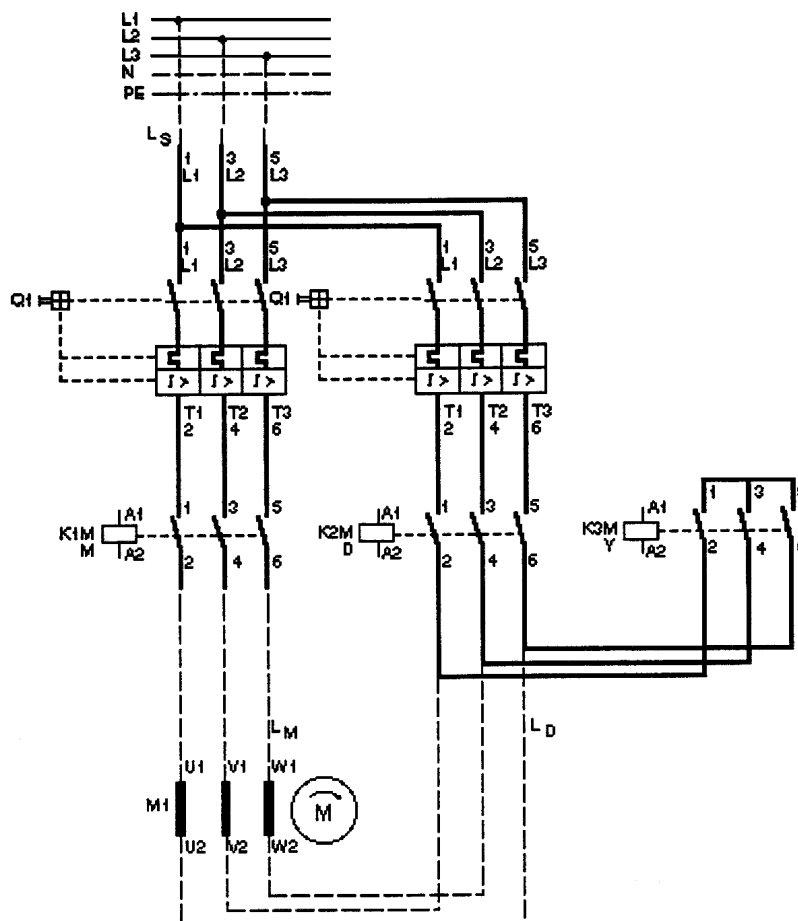

Fig. 3.2-6: Starter for star-delta starting with two circuit breakers for reduced cross-section of the motor connecting leads and suitable for heavy-duty starting.

For heavy-duty starting, the current setting of the circuit breaker connected upstream of the main contactor would be the minimum possible value between $I_e / \sqrt{3}$ and $1.25 \cdot I_e / \sqrt{3} = 0.722 \cdot I_e$ (eventually up to $1.7 \cdot I_e / \sqrt{3} \approx I_e$), at which setting there is no tripping during a normal starting.

The current setting of the circuit breaker connected upstream of the delta contactor would be equal to the phase current (rated current of the motor $I_e / \sqrt{3}$).

3.2.3. Protection during heavy-duty starting

The magnitude of the starting current of a motor is pre-defined by its design and construction. The running up time, however, depends on the load connected to it. If the running-up times and the starting currents are equal to or exceed the following typical values, usually one speaks of a heavy-duty starting :

Starting current [times the rated current]	4	6	8
Running up time[seconds]	10	6	3

As a rule, a standard circuit breaker with its given time/current characteristic will trip under the above conditions.

The tripping times of the thermal releases of a circuit breaker with motor protective characteristic are classified under tripping classes as is the general practice with other motor protective devices. The tripping classes are defined in IEC 947-4-1 for a reference overload of $I_{ref} = I_{ref} = 7,2 \times I_e$.

Fig.table: Tripping classes in accordance with the IEC 947-4-1 for thermally delayed overload releases.

Tripping class	Tripping time T_p in seconds
10A	$2 < T_p \leq 10$
10	$4 < T_p \leq 10$
20	$6 < T_p \leq 20$
30	$9 < T_p \leq 30$

3.2.4. Circuit breaker with a motor protective device connected downstream

If a motor protective device is connected downstream of the circuit breaker, the thermal overload protective function of the breaker is only of a secondary importance. The special electronic motor protection relay used exclusively for the purpose of the protection of the motor will take over these tasks. It has to be assured that the circuit breaker does not trip earlier than the motor protective device.

Normal starting conditions

The electronic motor protection relay takes care of the thermal protection of the motor and any other additional protective functions, if required.

The task of the circuit breaker is to break the short-circuit current rapidly and to indicate clearly and unambiguously the occurrence of a tripping due to a short-circuit. The thermal release of the circuit breaker may not trip earlier than the motor protective relay and its current setting would be higher than the rated current of the motor drive which is to be protected. The current setting could be the maximum of the current scale, but should not be less than 1.2 times the rated full-load current of the motor.

Heavy-duty starting conditions

Run-up times of the order of 30 to 60 seconds can be easily monitored and managed by the electronic motor protective system. This type of loading (7.2 times the rated motor current during most of the run-up time) requires not only a special selecting criterion of the motor, which has to withstand the thermal stress during the duration of the starting, but also of the contactors, circuit breakers and other associated devices used in the installation including the wiring and connections.

Selection of the circuit breaker

The thermal release of the circuit breaker may neither trip under normal service conditions nor under abnormal service conditions (overload, locked-rotor or loss of phase).

From a comparison of the time/current characteristic of the circuit breaker and the setting of the electronic motor protective device, it should be assured that the circuit breaker does not trip thermally. In many cases, it is sufficient to set the current equal to the maximum of the current scale of the thermal overload release, but sometimes it may be necessary to take the next higher sized circuit breaker.

Example: Motor drive of a centrifugal pump

22 kW / 400 V

Run up time $t_a = 60$ s

$$I_e = 43 \text{ A} \quad I_a = 6 \times I_e$$

1st estimation: 22 kW motor needs a circuit breaker type 140-CMN with the current range 40...63 A.

Starting current : $I_a = 6 \cdot I_e \cdot k = 6 \cdot 43 \text{ A} \cdot 0.85 = 219.3 \text{ A}$

(The starting current may be reduced by a factor $k = 0.85$ as the full starting current does not flow during the entire run up time).

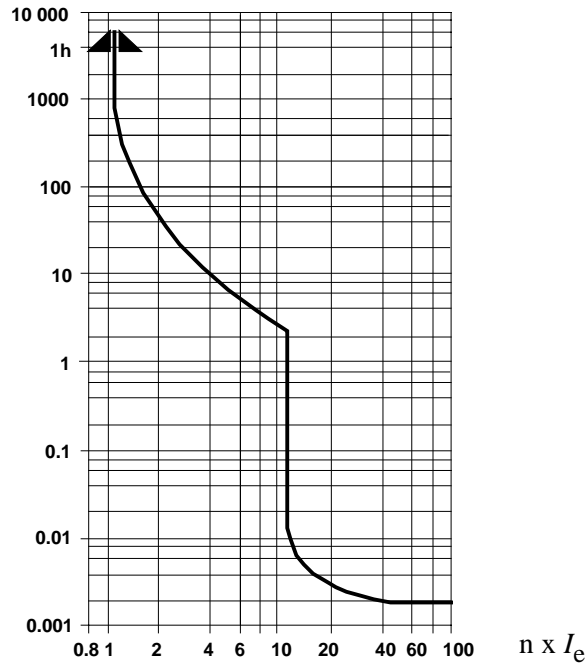

Fig. 3.2-7: Time/current characteristic of the Bulletin 140 -CMN

According to the time/current characteristic of the 140-CMN 63A, it trips within about 60s at 1.7 times the current setting. This means that the 63 A breaker trips with a current of $1.7 \times 63 \text{ A} = 102 \text{ A}$ after a delay of about 1 minute.

The appropriate circuit breaker must have a minimum current setting of

$$I_{\text{Skala}} = \frac{I_a}{1.7} = \frac{219.3 \text{ A}}{1.7} = 129 \text{ A}$$

The circuit breaker 140M-K5F is the right choice for this particular application.

If the co-ordination required is to be the type "2" conforming to the IEC 947-4-1, the size of the downstream contactor must be at least as published in the co-ordination table. As the thermal stress is higher, the following points are to be additionally considered for the selection of the contactors.

Selection of the contactor

The selected heavy duty contactor must not be thermally damaged due to the high let-through energy which the setting of the electronic motor protective device will let flow through it. The contactor, normally selected on the basis of the rated AC-3 current of the motor, may not be overheated due to the long duration of flow of the starting current.

The information about the permissible short time current which the contactor may withstand for a given duration without exceeding its thermal limits is published in the technical catalogue. The 0.85 times the starting current and the full run up time is the basis of selection from the table of short time withstand current of contactors (the starting current may be reduced by 15% as the full starting current does not flow during the entire run up time of $t_{\text{G}} \times I_{\text{e}}$).

Example: Motor drive of a centrifugal pump (the previous example)
22 kW / 400 V / $t_{\text{a}} = 60$ s

$$I_{\text{e}} = 43 \text{ A} / I_{\text{a}} = 6 \times I_{\text{e}}$$

1st estimation: On the basis of the utilisation category AC-3, a 22 kW/43 A contactor is selected (100-C43). The maximum permissible short time current for this contactor for a duration of 60 s is 200 A.

Calculation of the loading of the contactor during the run up.

$$\begin{aligned} \text{Starting current:} & I_{\text{a}} = 6 \cdot I_{\text{e}} = 6 \cdot 43 \text{ A} = 258 \text{ A} \\ \text{Reduced current taking the} & \\ \text{reduction factor into consideration:} & I_{\text{a}'} = I_{\text{a}} \cdot 0.85 = 258 \text{ A} \cdot 0.85 = 219.3 \text{ A} \end{aligned}$$

For this particular application with a centrifugal pump, a contactor which can withstand a current of 219 A for a duration of 1 minute without any thermal damage is to be selected (100-C60). Quite often, the appropriate contactor is to be over-dimensioned by 1 to 2 sizes than that selected on the basis of the rated current.

Selection of wiring and connections

The recommended cross-sections of the conductors in accordance with the standards are on the basis of the current setting of the thermal overload release under normal service conditions. If an electronic motor protection relay is used, the tripping time setting of $t_{\text{G}} \times I_{\text{e}}$ must also be considered.

With the help of the following diagram, the required cross-section of cable or wire with insulation made of synthetic material as a function of the current setting and the tripping time of $t_{\text{G}} \times I_{\text{e}}$ can be read out.

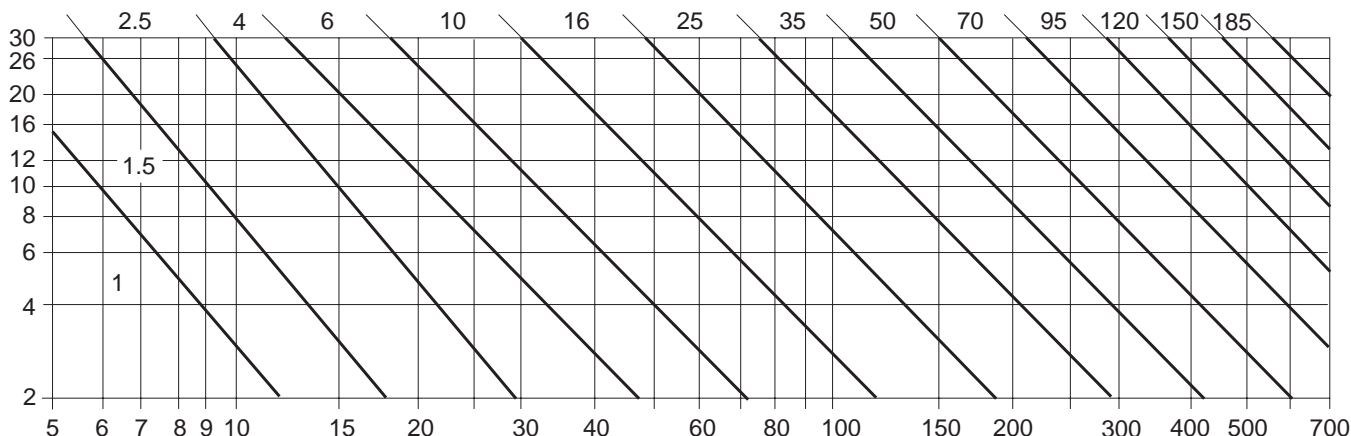

Diagram Fig. 3.2-8: Minimum cross-section of copper conductors which is still protected

Example: Motor drive of a centrifugal pump (the previous example)

Run up time $t_a = 60$ s

Current setting of the electronic motor protection relay: 43 A

Minimum cross-section of copper conductors which is still protected from the diagram: $A = 25 \text{ mm}^2$

3.2.5. Protection of motors in explosive environments

Special care must be taken for installations with explosion proof type of protection with increased safety EEx e. The temperature rise must not reach such high values during the service in any utilisation category so that the mixture of gases or vapours and air may ignite causing explosions.

For electrical motors, it must be assured that the maximum temperature of the "hot spot" even for operations under abnormal conditions may not exceed the lowest ignition temperature of the mixture of gas or vapour in question in accordance with the type of protection against explosion.

In the case of locked rotor and starting from warm state under normal service conditions, t_E is the time required for the motor to reach the limiting temperature rise.

The circuit breaker Bulletin 140 is suitable for protection of motors of type EEx e, provided the time t_E of the motors are at least equal to or longer than the standardised minimum values. If this condition is not fulfilled, the t_E value of the motor is to be compared with the time-current characteristic (tripping from cold state) of the bimetallic overload release of the circuit breaker. If the value of t_E lies on or above the characteristic of the circuit breaker, the protection of the EEx e motor is assured.

The verification and certification through the Physikalisch-Technischen-Bundesanstalt (PTB) of Brunswick, Germany confirms that the circuit breaker is suitable for the protection of EEx e motors.

The stringent requirements of the PTB is fulfilled by integrating a motor protective tripping characteristic (including ambient air temperature compensation) and a phase-loss sensitive release mechanism causing a rapid tripping in the case of the loss of a phase.

3.2.6. Protection of motors with phase controlled starting (soft starter) Overload protection:

The soft starter prolongs the run-up time of the motor, at the same time reduces the starting current and the torque. From the point of view of a soft starter, extremely severe starting conditions like a long, heavy-duty starting can be easily handled without any problem whatsoever. From many possible applications, let us take the starting of a ventilator as an example. The pre-requisite is though that the soft starter is correctly selected.

The circuit breaker with a current setting equal to the motor rated current and with its motor protective characteristic, faithfully reflects the temperature rise of the motor also during the soft starting. The harmonics generated by the phase controlled starter and causing additional heating will be also "sensed" by the circuit breaker. For this reason, they are suitable for the protective task just like a thermal overload relay.

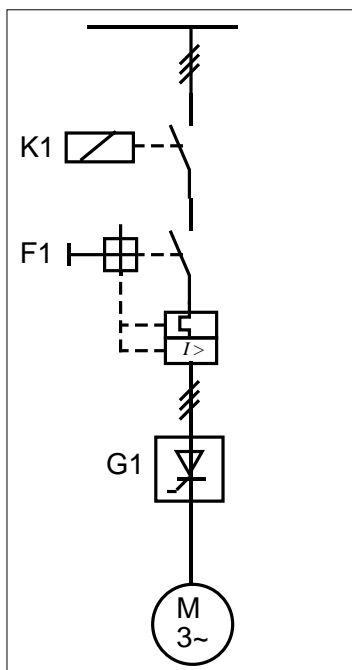

Fig. 3.2-9: Diagram showing the principle of connection of the main current path with a circuit breaker, main contactor and soft starter.

Installations permitting heavy-duty startings with soft starters and having run-up times of 100 seconds or even longer, require special ratings of not only the motors but also of the switching and especially the protective devices as well.

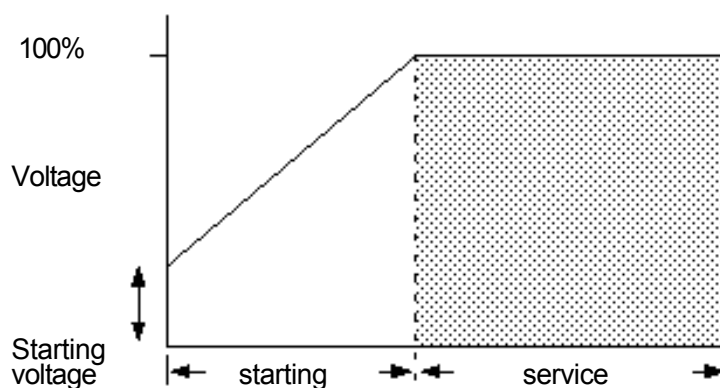

Fig. 3.2-10: With the help of soft starters, long run-up times can be realized.

Motors controlled by soft-starters and meant for heavy-duty starting are best protected by electronic motor protective devices. The current setting of the circuit breaker should be such that it must not trip earlier than the motor protective device (prevention of early tripping).

The selection and setting of the circuit breaker will be similar to the conditions of heavy-duty starting as described under the heading "Protection during heavy-duty starting". The sole duty of the circuit breaker in this case is to assure the protection of the connecting leads or protection against short-circuit.

Short-circuit protection :

The power semi-conductors are sensitive against short-circuits. A circuit breaker is not fast acting enough to protect a soft starter effectively against a short-circuit. The tripping times, especially in the lower ranges of overcurrent between 2 to 13 times the rated current are too long. For the short-circuit protection, the data sheet of the soft starter is to be consulted.

3.2.7. Protection of frequency controlled motors (frequency converter)

Overload protection:

Motors controlled by frequency converters are not directly connected to the supply (they are connected via rectifier and the inverter with the connecting circuit

in between - see the circuit diagram). The circuit breaker which is connected upstream of the frequency converter do no longer receive any direct information over the thermal state of the motor. For this reason, it can not take over the function of motor protection. Normally, the motor protective functions are integrated in the output circuit of the frequency converters.

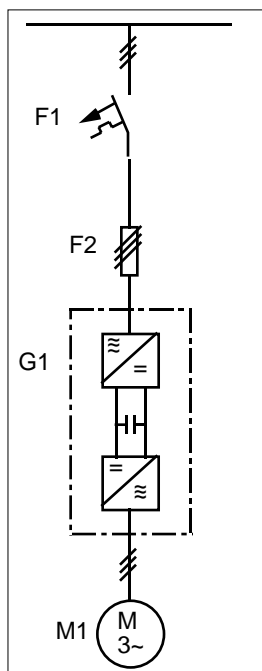

Fig. 3.2-11: Circuit diagram of the main current path of a frequency converter consisting of rectifier and the inverter with the connecting circuit in between.

Current consumption of an induction motor supplied by an inverter

The current drawn by a 3-phase asynchronous (induction) motor depends on the slip. The variable frequency supply of the inverter makes it possible to run-up the motor with the rated slip and thus with the rated current. By adjusting the voltage accordingly, the motor supplies the rated torque. The motor does not draw a high starting current as it would have been in the case of a direct starting.

The motor current consists of resistive and reactive components. The reactive component will commute between the capacitances of the connecting circuit and thus will not affect the supply. The mains will supply only the resistive component of the load current, its losses and the losses of the inverter. The power factor $\cos \varphi$ of the supply side is practically 1 due to the reasons mentioned above. Under the same load conditions, the current at the supply side is thus lower in the case of a frequency controlled motor than a motor connected directly to the supply.

The setting of the thermal overload of the circuit breaker should be about 1.2 times the rated current but must not exceed the permissible current rating I_Z of the connected load.

Short-circuit protection

Short-circuit at the supply side :

The circuit breaker at the supply side must protect the installation against a short-circuit occurring between the lines or between a line and the ground. The frequency converter itself seldom causes a short-circuit and will not be damaged by a short-circuit occurring at the supply side.

Circuit breaker connected at the outgoing side of the frequency converter

If a circuit breaker is installed at the outgoing side of a frequency converter, it must be able to withstand the pulse frequency of a few thousand Hertz of the output signal. Otherwise, the circuit breaker could be over-heated. Please consult the manufacturers in such cases.

3.3. Circuit breakers for the protection of connecting leads and for group protection

3.3.1. Protection of the connecting leads

Circuit breakers are suitable for the protection of the connecting leads. The current setting of the overload release should be equal to the maximum permissible current of the lead.

In many cases, circuit breakers with standard breaking capacities are quite sufficient for the protection of the connecting leads. Due to the current limiting effect of even a short length of connecting conductor, a circuit breaker with high breaking capacity is mostly not needed. It pays to carry out an exact calculation for the right selection of the ratings.

Permissible length of the connecting leads :

A rather unusual aspect is the necessity that the minimum required short-circuit current should flow through the circuit. The reduction in the short-circuit current due to a small cross-section and a long length of the connecting lead could be so extreme that it may not be sufficient to energise the magnetic release of the circuit breaker. The shock-hazard protection at the site of the short-circuit must be assured (in accordance with the IEC 364-4, the touch potential U_B for shock-hazard protection for a.c. may not exceed 50 V, and if U_B is more than 50 V then its duration may not be longer than 5s).

If necessary, please consult tables giving the maximum permissible length of the connecting leads (depending on the supply voltage and conductor cross-section).

3.3.2. Group protection

A circuit breaker for group protection protects, as for example a group of devices in an installation or a whole machine. Mostly, it serves the purpose of the protection of the connecting leads and helps to reduce the cross-section of the conductors inside the group. Additional short-circuit protective devices are connected downstream of the circuit breaker for group protection.

The short-circuit protective device connected downstream is mostly with a high making/breaking capacity. Hence, it is not necessary to use a circuit breaker with high interrupting capacity for the group protection. A relatively simple, non-current-limiting circuit breaker or even a load-break switch can perform this task, provided the installation is appropriately dimensioned.

If, however, the short circuit protective device connected downstream do not have sufficient breaking capacity, the circuit breaker for group protection can support it during the breaking operation of a short-circuit. In this case, it takes over the task of a back-up protective device (similar to a back-up fuse). Both the short circuit protective devices, connected in series opens simultaneously. The condition is, that the let-through current of the circuit breaker for group protection may not exceed the making/breaking capacity of the downstream circuit breaker.

If a time graded switching of the short circuit protective devices connected in series is desired, the selectivity-features (discrimination) of the devices are to be considered. To decide the selectivity (discriminating features) of the short circuit protective devices among each other, the technical publications of the manufacturers are to be consulted.

3.4. Circuit breakers for capacitors

In accordance with the standard IEC 33, capacitors must be able to withstand a continuous current, the r.m.s. value of which may not exceed the 1.3 times the current which will flow under rated conditions if the voltage and the current were sinusoidal.

For this reason, no overload protection is provided for capacitors in most of the applications.

The current setting of the thermally delayed overload release of the circuit breaker used for overcurrent protection should be 1.3 ... 1.43 times the rated capacitor current. The permissible tolerance in the ratings of capacitors is +10%, and hence the actual capacitor current could be $1.1 \times 1.3 = 1.43$ times the rated current of the capacitor.

During switching on of a capacitor, especially if a capacitor is connected to a capacitor-bank which is already charged, very high peak values of transient inrush current may result. The peak value of this inrush current depends, among others, on the ratio of the frequencies of the oscillatory circuit of the capacitor circuit and that of the supply.

Experience shows, that in most of the cases if the magnetic release has a tripping threshold equal to about 10 ... 12 times the rated current of the capacitor, a tripping due to the inrush current which is often very high but mostly of a short duration (quickly decaying) can be avoided.

3.5. Circuit breakers for transformers

3.5.1. Protection of transformer: primary side

For the protection of a transformer with a circuit breaker connected to the primary side, the no-load inrush current of the transformer must be considered. Due to the saturation of the magnetic core, a magnetising current of the order of 15 to 20 times the rated current of the transformer may flow for a short duration.

Although the high inrush current decays to a lower value within a few milliseconds, it may cause the magnetic release of the circuit breaker to trip, especially in the case of rapid acting current limiting circuit breakers. Relatively slow acting circuit breakers are more suitable in this case, especially if the magnetic release is adjustable and a higher setting can be selected or if a time-delayed tripping is possible.

3.5.2. Protection of transformer: secondary side

Similar to motors, transformers can also withstand a certain overload, depending on pre-loading and the temperature of the cooling medium. Transformers are less sensitive than motors against overloads of short duration. In this case, the circuit breaker provides over-protection against thermal overloads, but is still suitable as a protective device for transformer.

The breaking capacity of the circuit breaker connected to the secondary side of a transformer must be at least equal to or higher than the short-circuit current calculated on the basis of the short-circuit impedance of the transformer. The current setting of the thermal overload release of the circuit breaker is equal to the rated current of the transformer.

The task of short-circuit protection is taken over by the magnetic release. If selectivity with the downstream short circuit protective device is desired, then circuit breakers with time-delayed overload releases are to be taken.

3.6. Circuit breakers for generators

Basically, circuit breakers are suitable for the protection of generators. Smaller single units (marine generators, stand-by or special purpose generators) are mostly protected by current limiting circuit breakers without time delay. For larger generators and especially for parallel operation of generators, special circuit breakers with time delayed tripping are to be used.

The current setting of the overload release of the circuit breaker should be equal to the rated current of the generator. The setting of the magnetic release should be a little lower than the continuous short-circuit current of the generator.

Due to the construction and design of the modern day generators, the peak value of the a.c. short-circuit current is in most of the cases more than 6 times the rated current of the generator, in some cases even higher than 7 times. Circuit breakers with the threshold of the magnetic release set at less than 6 times the rated current of the generator "sense" practically all the short-circuits within the first half-cycle. Current limiting circuit breakers without time de-lay interrupt the short-circuit current practically instantaneously and thus assure the protection of the installation.

For this reason, circuit breakers with fixed and higher threshold of the magnetic release are not suitable for the protection of generators.

For short-circuits far away from the generator so that the short-circuit current is very much reduced (short-circuit current lower than the threshold of the magnetic release), the thermal and the electro-dynamic stresses on the installation is also correspondingly lower. In such cases the task of the short-circuit protection is taken over by the thermal overload release.

3.7. Circuit breaker for special supply frequencies

Basically, the interruption of the current occurs with the quenching of the arc. In the case of an alternating current, the arc is extinguished at each passage of the current through zero. This is the advantage of the alternating current that the current can flow again only if the arc re-strikes in the next half-cycle after the quenching at the current-zero. The current flowing through the arc is successfully interrupted if one can prevent the re-striking of the arc after its quenching at the current-zero. This is the principle of the quenching of the arc in the case of the alternating current. This is achieved by de-ionising the contact gap after the contacts have opened, i.e. the space between the contacts which was previously conducting due to the ionising effect of the arc, and increase the dielectric strength of this stretch by cooling to such an extent that the recovery voltage across the contacts after the interruption can not re-strike an arc through it. This principle is utilised for arc quenching by contactors and non-current limiting circuit breakers.

In the case of current limiting circuit breakers, an "artificial current-zero" is created. For this reason, these breakers can also interrupt direct current.

3.7.1. Breaking capacity at frequencies below 50/60 Hz

Quick acting, current limiting circuit breakers, do not need a current-zero for the interruption of the current. They react already at the initiation phase of the short-

circuit during the first half-cycle of the sinusoidal current wave. Whether the current-zero occurs after 10 ms (for 50 Hz) or after 30 ms (for $16\frac{2}{3}$ Hz) is no longer relevant as the short-circuit is interrupted long before the occurrence of the current-zero (the clearing time of the current limiting circuit breaker is shorter than a half-cycle). The breaking capacity remains unchanged.

The fault level of the supply network ($16\frac{2}{3}$ Hz) for traction (railways) are usually rather low due to the long length of the conductors. The short-circuit withstand capacity of the on board supply system of the trains are also not especially high. As a rule, current limiting circuit breakers without any modifications can be used here.

For a current-zero interrupting type of circuit breaker, the breaking capacity is reduced. The published data of the manufacturer is to be consulted.

3.7.2. Breaking capacity at frequencies above 50/60 Hz

The time between the current-zeroes decrease with increasing frequency. At the same time, the peak value of the half cycle of the short-circuit current will be attained faster. Assuming that the opening speed of the circuit breaker remains unchanged, the let-through current of the circuit breaker will be higher and higher. The circuit breaker would be strongly heated. To prevent permanent damage to the circuit breaker, the breaking capacity is to be reduced at higher frequencies.

In general, the short-circuit capacity of the medium frequency generators are relatively low. Hence the eventual slight reduction (referred to 50/60 Hz) in the breaking capacity at frequencies above 400 Hz do not restrict the use of the circuit breaker in practical applications.

3.8. Interruption of direct current

Contrary to the alternating current, there are no current-zeroes occurring in direct current. Contactors depend on the passage of the current through zeroes for the quenching of the arc which the current limiting circuit breakers do not. Thus, the short-circuit breaking capacity referred to the a.c. value is hardly reduced at direct current.

The rate of rise during the initiation of the short-circuit current at d.c. (which depends on the time constant of the d.c. circuit) is quite comparable to that of a.c. Only the rate of rise of the short-circuit current is the decisive factor for the opening delay of the contacts in the case of a current limiting circuit breaker. As soon as the arc is blown by the magnetic field of the current towards the arcing chamber and is quenched there, the current is interrupted, independent of the fact when or if at all a current-zero follows or not.

In practical applications, a current limiting circuit breaker at d.c. can be used for the same value of the rated short-circuit breaking capacity as in a.c. Different it is for normal switching of d.c. currents. The technical documents of the manufacturer have to be checked. The tripping threshold of the magnetic short-circuit release is slightly higher in the case of d.c.

To assure a symmetrical operation of the thermal overload releases, it is recommended for circuit breakers as well to connect all the poles in series (this is mandatory if provided with differential release, similar to the thermal overload relays). In addition, the series connection leads to a quicker interruption of the current.

3.9. Breaking capacity at higher supply voltages

The breaking capacity at 690 V is less than that at 400 V. In single phase applications at higher voltages (>400 V), the breaking capacity of three pole circuit breakers can be increased by connecting the poles in series (similar to switching in cascade).

Whether the rated short-circuit breaking capacity with series connection will attain the value as at 230 V again, is to be checked for each individual application.

3.10. Selectivity (discrimination)

On economical grounds and for the reason of reliability of the service, it is not always ideal to interrupt the supply to the installation in the case of a fault as fast as possible. The protective device immediately upstream of the fault must respond at first. Only the faulty part of the installation should be isolated. All the other switching and protective devices connected to the system should remain operative. Selectivity reduces the duration of a fault and limits its possible damaging effect only to a part of the installation. The service interruption is reduced to a minimum.

3.10.1. Selectivity between circuit breakers

Current selectivity

In a distribution network, the ratings of the distribution circuit breakers will be smaller and smaller as we go downstream from the transformer to the load. Similarly, the settings of the short-circuit magnetic releases will be also lower and lower. At the same time, the magnitude of the short-circuit current which may occur will be also progressively lower. This results in a sort of natural selectivity depending on the magnitude of the short-circuit current. The principle of current selectivity is applied mostly for distribution feeders at the extremity

of the system, with appreciable reduction of the short-circuit current due to the long length of the leads. The prospective short-circuit current at the location of installation of the circuit breaker must be known.

Two circuit breakers are mutually selective if the short-circuit current flowing through the downstream breaker is lower than the (adjustable) threshold of tripping of the magnetic release of the unit connected upstream. This value is considered as the limit of selectivity.

Whether two circuit breaker are really mutually selective is checked by comparing the time-current characteristics of the breakers. The tripping characteristics of the two breakers may not touch or intersect each other up to the maximum value of the permissible fault level. There must be a definite spacing between the two characteristics, depending on the permissible tolerance band of the releases of the breakers.

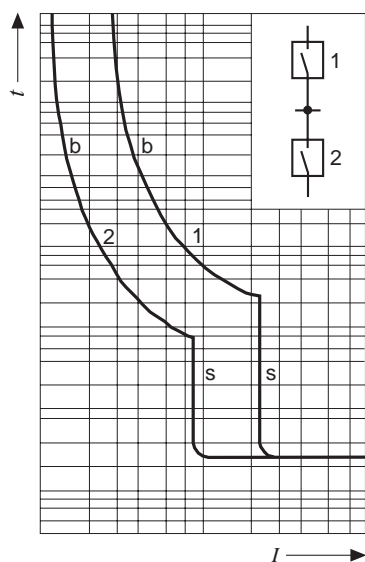

Fig. 3.10-1: Time-current characteristics of two current-selective circuit breakers

Although the method of comparison of the time-current characteristics is exact, it is also time consuming. The published tables of the manufacturers, indicating the selectiveness of the circuit breakers among one another makes the selection easier.

As far as overload is concerned, the thermally delayed bimetallic overload releases of the circuit breakers with different rated currents are always selective to one another. The tripping times of the different ratings of the circuit breakers for the same overload currents are automatically different (as for example the 100 A version and the 6.3 A version).

Time selectivity

If current selectivity can not be achieved, as for example between two quick acting circuit breakers having practically the same reaction time, selectivity is to be realised via the adjustable delay time of the breakers.

The time selectivity in the case of large circuit breakers for the protection of installations is realised by delaying the magnetic tripping time by a few half cycles. The total clearing time of the downstream circuit breaker must be shorter than the minimum necessary duration of the command time of the circuit breaker connected immediately upstream. In other words, for mutually selective circuit breakers acting in time staggered sequence : the delay time of the upstream circuit breaker must be longer than the total clearing time of the circuit breaker connected downstream.

The minimum delay time that can be realised between the time staggered circuit breakers are 60 or 100ms. The tripping characteristic of the delayed breaker is shifted upwards on the published time-current characteristic diagram.

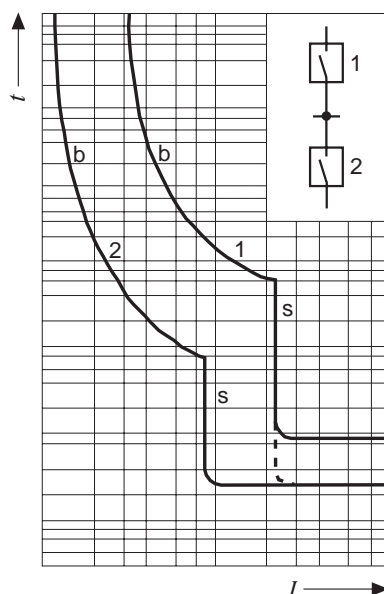

Fig. 3.10-2: Time-current characteristics of two time-selective circuit breakers.

The time selectivity between circuit breakers reacting in a time staggered sequence is achieved by not allowing the contacts or the magnetic release to react directly with the short-circuit current. A mechanically delaying mechanism or an electronic circuit delays the action of the circuit breaker.

For the upstream circuit breaker, one can no longer speak about a quick acting, current limiting interruption. More than one half cycles of the actual short-circuit current flows through the delayed acting protective device and also through the installation. This, obviously, is to be designed accordingly to withstand this stress.

3.10.2. Selectivity between circuit breaker and fuse

For a serious decision and checking of the mutual selectivity between a circuit breaker and a fuse in an installation, the best method is to super-impose and compare the time-current characteristics of the devices on a diagram.

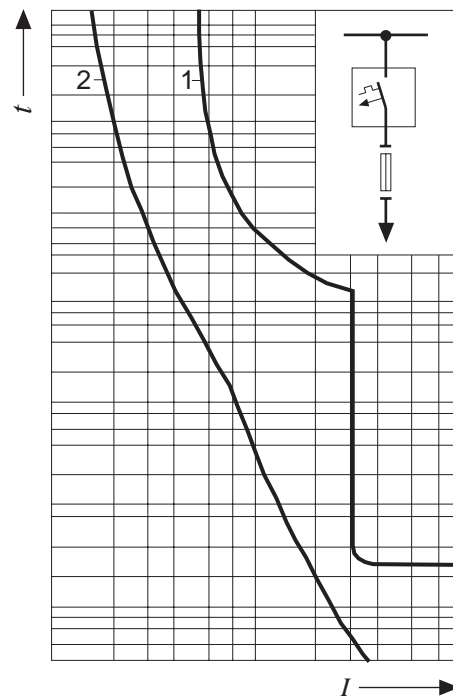

Fig. 3.10-3: Selectivity between a circuit breaker and a HRC fuse connected downstream.

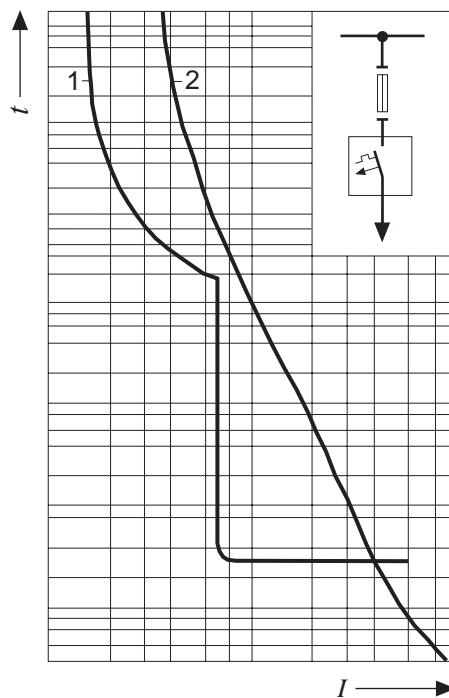

Fig. 3.10-4: Selectivity between a HRC fuse and a circuit breaker connected downstream.

Selectivity is then assured, if the tripping curve of the downstream device lies completely under the time-current characteristic of the upstream short circuit protective device. In practical applications, a time interval of minimum 60ms between the two characteristics is to be assured.

Adjustments can be done by changing the threshold of tripping current (shifting of the characteristics in a horizontal direction) or by delaying the tripping time (shifting of the characteristics in a vertical direction).

3.10.3. Selectivity between fuses

The conditions of selectivity is fulfilled if the Joule-integral needed for the melting of the upstream fuse is higher than the total clearing Joule-integral of the downstream fuse. This is the case when the rating of the upstream fuse is about 1.6 to 2 times the rating of the downstream fuse. The factor varies, depending on the different types and standards as well as on the manufacturers of fuses.

Experience shows that with a ratio of 1:2 between the ratings of the fuses, selectivity is assured in practical applications. With smaller ratios, faulty operation may result due to the ageing of the fuses.

Circuit Breaker

4. Arguments in favour of the circuit breaker

4.1 Summary

Circuit breakers (including miniature circuit breakers) are extensively used in industrial as well as in domestic applications. Especially where the accent is on the reliability of the installation, the fuse-free technology is preferred. The circuit breaker is the modern protective device.

Thus one may take advantage of the numerous advantages of the circuit breaker like the integrated signalisation and communication, reduced risk of accidents during manipulations as well as much simplified planning of the installation.

In spite of the above, one must not detract from the many positive features of the fuse. The short-circuit breaking capacity of 100 kA is so high that a selection based on the location of installation of the fuse is totally superfluous. Another positive point is the excellent current limitation even at higher prospective short-circuit currents. The short-circuit co-ordination type "2" in accordance with the IEC 947-4-1 between contactors and fuses is thus very simple (no over-dimensioning of the contactors). The easily attainable selectivity between fuses is definitely another argument in favour of the fuse.

The advantages of the circuit breaker over the fuse are:

- replaces the combination of the fuse and the motor protective relay.
- possibility of signalisation.
- remote control possible under certain circumstances.
- the circuit breaker can be immediately switched on again (after an interruption).
- all-pole switching (phase loss not possible).
- no ageing.
- a motor protective tripping characteristic is possible.
- reduction of conductor cross-section is possible.
- more operational safety.
- planning of the installations can be standardised.
- segregation can be reduced.

4.2. Comparison of the functions : circuit breaker / fuse

4.2.1. Time-current characteristics

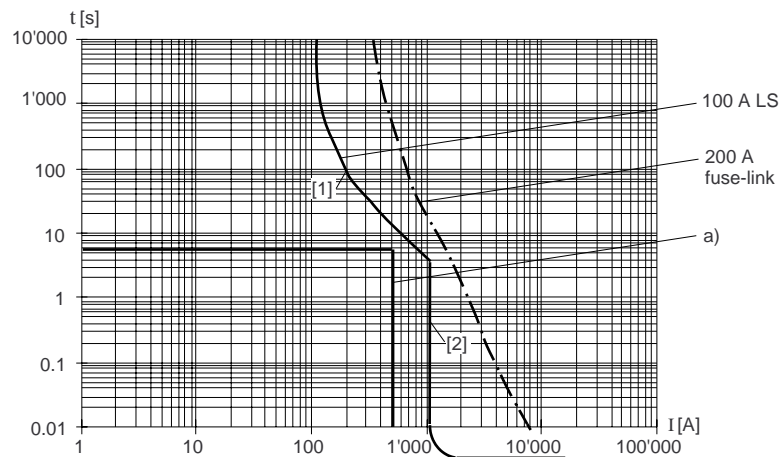

Fig. 4.2-1: Time-current characteristics of a 100 A circuit breaker and a 200 A fuse-link.

Solid thin line: The circuit breaker with its typical characteristics of the overload release ([1] bimetallic) and the short-circuit tripping mechanism ([2] electro-magnetic release).

Dashed line: Characteristic of a fuse, a relatively continuous curve.

Solid thick line: Check-point (a) of a 100 A motor with a starting current (85 % of $6 \times I_n$), which reduces down to the rated current within about 6s. To prevent a nuisance tripping during the running up, this check-point may not lie above the characteristic of the protective device. The rating of the fuse must be higher than the rated current of the motor and therefore the cross-sections of the connecting leads are to be increased.

The rating of a fuse is to be chosen one or two sizes higher than the motor rated current so that the starting of the motor is possible. The reason is apparent from the run-up characteristic of the motor. The conductor cross-section is to be chosen in accordance with the rated current of the selected fuse.

The bimetallic overload release of the circuit breaker reproduces the behaviour of the motor during starting as well as during normal service. At the threshold of tripping of the electro-magnetic release, the tripping time reduces down to the mechanical delay of the breaker (release mechanism). In the case of small, current-limiting circuit breakers (with electro-magnetic striker) this delay is further reduced with increasing short-circuit current.

4.2.2. Comparison of Joule-integrals

The Joule-integral ($I^2t = \int_{t_0}^{t_1} i^2 dt$) (also sometimes called the let-through integral or energy) of a circuit breaker increases with increasing short-circuit current (a larger current is to be interrupted in almost the same time). In the case of the fuse, it is just the opposite. With increasing current, the fuse melts faster (reduction of the Joule-integral) till a minimum value is reached under which it can not sink. This is called the region of constant $I^2t \approx$.

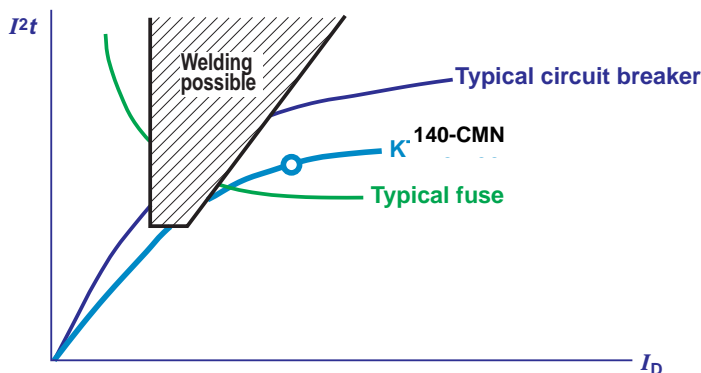

Fig. 4.2-2: Comparison of Joule-integral-characteristics of the circuit breaker and the fuse. The Joule-integral expressed as a function of the cut-off current.

Note: This is not the usual way of representation. These curves are obtained by eliminating the prospective short-circuit current from the usual representation of the Joule-integral and the cut-off current as functions of the prospective short-circuit current.

The Joule-integral of a fuse decreases with increasing short-circuit current to a practically constant minimum value. Above the tripping threshold of the magnetic release of the circuit breaker, the Joule-integral increases continuously with increasing short-circuit current. Quick acting, effectively current limiting circuit breakers have let-through values which do not cross or just touches the critical region of welding of the contactors. The let-through characteristic of the fuse, especially at lower prospective short-circuit currents, may enter the critical region of welding of the contactors.

Investigations of industrial installations have shown that in 400 V radial distribution net-works with a transformer rating of up to 2'000 kVA, very high short-circuit currents occur in extremely rare cases as most of the short-circuits take place at the load distribution branches. With parallel connection of the supply transformers, although short-circuit currents of the order of 50 kA or even 100 kA is theoretically quite possible, the magnitude of the short-circuit currents in 90 % of the cases lie under 9 kA, with a mean value of about only 2.8 kA.

Therefore it is important that short-circuit currents of low or intermediate magnitudes should be also interrupted quickly and reliably. The circuit breakers fulfil this task more competently.

4.2.3. Comparison of the ultimate tripping current

The test currents for the fuses are grouped as functions of their rated currents in the standard IEC 269. For all fuses above the rating of 25 A, a test current I_2 equal to 1.6 times the rated current of the fuse is to be taken. In the case of circuit breakers (with motor protective characteristic), the ultimate tripping current in accordance with the IEC 947 is uniformly 1.2 times the current setting. Thus the release threshold of the fuse is 30 % or even higher than that of the circuit breaker. The fuses are designed for protection against short-circuit whereas the circuit breakers can protect motors and their connecting leads against overload as well.

4.2.4. Table of comparison

The following is a comparison of load feeders with fuses and of "fuse-free" design from the points of view of

- project planning
- protective functions
- operation and maintenance

Planing phase			
I_k -calculation required	no	no	yes
Additional use of space	yes	yes	no
Expenditure for service, access	high	high	high
visible isolation gap	smaller	smaller	yes
Remote control and electrical or mechanical interlock	no	yes	yes
Space fuses and accessories required	yes	yes	no

Table Fig. 4.2-3:

- The application of circuit breakers require a short checking and comparison of the possible short-circuit current at the location of mounting of the circuit breaker and its making and breaking capacities.

Circuit Breaker

- Remote control and electrical or mechanical interlocking is possible with some circuit breakers.
- It is not necessary to keep replacement fuse-links readily available at the site.

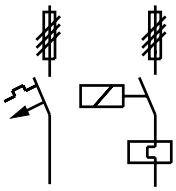
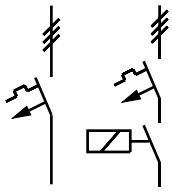

Protection functions				
Thermal overload prot.	Fuse	Circuit breaker	Relay	Circuit breaker
Short-circuit protection	Fuse	Circuit breaker and fuse	Fuse	Circuit breaker
Switching capacity	100 kA at 690 V, 50 Hz			I_{cu} [100 kA at 500 V (25 A)]
Current limiting char.	depends on I_n and I_k			dep. on constr., I_n , I_k , U_n
Let through energy	>at low I_k const. at high I_k			<at high I_k >at high I_k

Table Fig. 4.2-4: In the case of circuit breakers a comparison of the maximum possible short-circuit current at the location of mounting of the circuit breaker and its making/breaking capacities is necessary. The switching capacities depend on the construction and the type of the breaker.

The Joule-integral decreases with increasing prospective short-circuit current for fuses whereas it increases in the case of circuit breakers (deciding factor for the selection of contactors for short-circuit co-ordination).



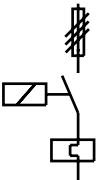
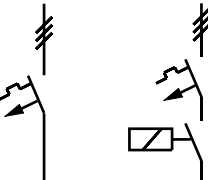

Service				
Operating safety	Question of expenditure			good
Switches off at overload Resetability	Fuse no	Breaker yes	Contactor yes	Circuit breaker yes
Switches off at short-circuit Resetability	Fuse no	Breaker or (and) fuse yes/no	Fuse no	Circuit Breaker yes
Trip indication	possible	yes	possible	yes
Measurements after trip replace fuse control breaker and (or) contactor	yes no	no/yes yes	no/yes yes	no yes
Damage to the correct operation occurred	no	no/yes	no/yes	no (coord. Type "2")
Visibility of correct function at fuse at circuit breaker and contactor	yes	yes no	yes no	no
Disconnection of 3 poles	no	no/yes	no	yes

Table Fig. 4.2-5:

- Simple tripping indication in the case of the circuit breakers with the help of signalling contacts.
- A newly fitted fuse-link is so to say virgin. In the case of the circuit breakers, the proper functional features depend on its pre-history, i.e. the number and the magnitudes of the short-circuit currents the circuit breaker had to handle previously.
- A circuit breaker always interrupts all the poles. Depending on the applications, this feature may be considered as an advantage or a disadvantage (motor feeders / street lighting distribution with redundancy).

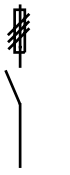
4.3. Arguments in favour of the circuit breaker

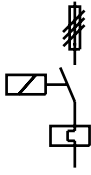
4.3.1. Prevention of accidents with the help of circuit breakers

Operation of the short circuit protective device:

International statistic shows that on an average fuses are involved in one out of two fatal electrical accidents. Although all the electrical accidents do not end fatally, it is dramatically apparent that the handling of this particular short circuit protective device could be critical and hazardous.

The highest risk of injury is during the insertion of the disconnecting blades and the fuse-links, if a capacitor bank is connected to the outgoing end or there is a

short-circuit. Even on-load breaking operations for rated currents above 100 A could be delicate. For this reason, the national associations for professionals and the organisations for the prevention of accidents lay special stress on the observation of the operational standards about the handling of the fuse-links. The manufacturers of the fuses are continuously modifying the design of the fuses to improve their safety in use.

In spite of the fact that the fuses conform to all international standards, their manipulation as far as maximum safety of the operating personnel is concerned, is possible only in combination with the appropriate and necessary accessories. A protective clothing consisting of a handle, leather gauntlets (or gloves for screw type fuse-links), leather apron and a face mask as protection against the arc which may strike during the insertion of the new fuse-link is not only recommended but in some cases even stipulated. Obviously, it would hardly help if the material is not at all or wrongly utilised.

Such hazardous situations do not arise with circuit breakers, thanks to the different principle of operation and construction. The handling or manipulations always take place outside the zone of danger. All the active electrical parts under tension are securely packed inside the housing of the breaker. The arc can not spread out of the breaker in an uncontrolled fashion.

There are no stipulations or recommendations for protective clothing as far as operations with circuit breakers are concerned. Specifically instructed persons even though unskilled, as for example the operating staff of an installation, may perform the switchings. There is no danger even in an open installation because of the pre-conditions of design and construction of the circuit breaker and also their method of installation. No special standards for the prevention of accidents has been issued by the accident insurance companies as far as the operation of circuit breakers is concerned.

Behaviour during the breaking of a short-circuit

The hazard of the fuse is not during the breaking of a high short-circuit current which may occur due to a direct short-circuit of the conductors. It is rather due to the long clearing time of the fuse for short-circuit currents of lower magnitudes.

As a rule, practically all the short-circuits occur over an arc and hence short-circuit currents of low to medium magnitudes are most common. The reason is that the resistance of the arc and the impedance of the connecting leads effectively reduces the value of the short-circuit current.

The long clearing time and the accompanying heating due to it is favourable for the continuation of the burning arc. It also may cause a dangerous explosive blow out of the hot or sometimes even the molten cooling medium, viz. quartz sand.

A circuit breaker operates appreciably faster than a fuse in the range of the most (A) commonly occurring short-circuit currents. It will be apparent from a comparison of the time-current characteristics (see Fig.).

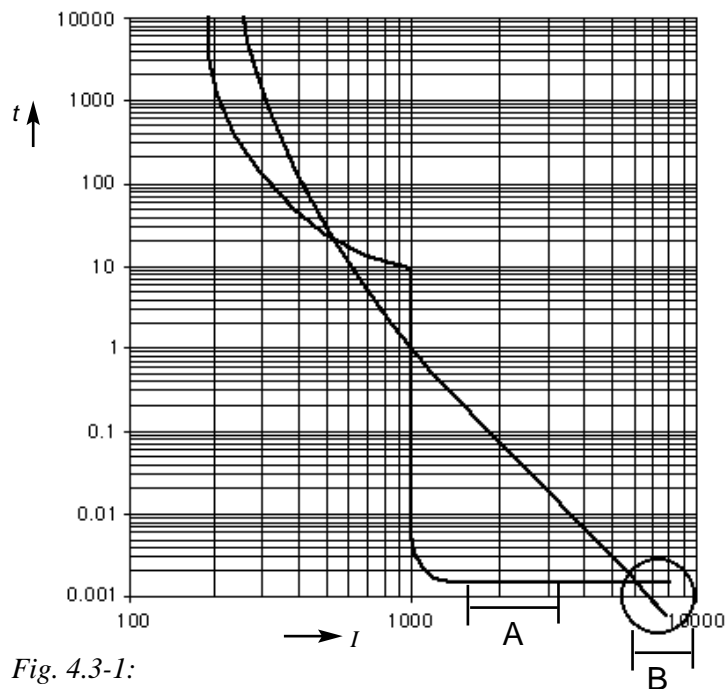

Fig. 4.3-1: Comparison of the time-current characteristics of circuit breaker and fuse. With increasing short-circuit current, the clearing time (B) of the fuse will be shorter than the mechanical delay time of the circuit breaker. The physical working principle of the fuse leads to the fact that it clears a fault faster than a circuit breaker.

A higher safety of the operators is achieved by using circuit breakers as the possible damage to the installation caused by a fault is kept to a minimum due to the fast interruption of the short-circuit current. A simple movement - push a button, rotate a handle or change the position of a lever - is sufficient for making or breaking the current or resetting the device.

4.3.2. Ready to be switched on again without delay

The down time of an installation is an important economic factor. Consider the time it needs to locate the blown-up fuse-link inside a cabinet, find out its rated value, find an appropriate replacement from the stock which is to be maintained for this purpose and then replace the new fuse-link back to its place after putting on the protective clothing including the face mask, gauntlets etc. as stipulated by the standards.

There is no clear-cut signalisation of the on, off or tripped (blown-up) state of the fuse as it is with the circuit breaker. The localisation of the blown-up fuse alone is more time consuming than in the case of the circuit breaker.

After a tripping due to overload and allowing for a short pre-defined cooling period, the circuit breaker is ready to be switched on again and take over its protective functions fully without any restrictions or alterations. This is true also after the interruption of a short-circuit.

4.3.3. All pole interruption

In majority of the cases, a load is interrupted on all the poles. Contactors, load switches or circuit breakers perform this task, only the fuse can not. Only in exceptional cases, the fuses in all the phases do melt simultaneously. The critical running of three phase motors after the loss of a phase can be prevented if the protective device is a circuit breaker.

Let us take the example of a hoisting gear (as for example a rotating crane mast) with a fuse as the protective device for the driving motor. After the fuse is blown-up in one phase, the motor running with only two-phase supply (sometimes erroneously called single-phasing) can not be reversed (plugged). The load may slide down uncontrolled to the safety periphery of the crane. The circuit breaker assures this safety of operation. A load will always be interrupted on all the poles. The loss of a phase is not possible.

Often in distribution net-works all-pole interruption is not desired (redundant circuit as in street lighting). In these cases, single pole circuit breakers or miniature circuit breakers are to be used.

4.3.4. No ageing

The fuse (type gG) alters its characteristic as soon as it is loaded above about 15 % overcurrent, i.e. at each motor starting or overloading. This process is called ageing.

Ageing

A motor with a rated current of 30 A and protected by a 63 A fuse, has a starting current of 150 A in the present example. According to the rule mentioned above, the fuse will not age only up to a current of 72 A. Hence, it will be loaded with double as much current at each starting. It is the metal-alloy part of the fuse-link which is actually aged. With each overload, this part is heated and the molecules of the deposited alloy diffuses into the fusible link thereby increasing its resistance. During the next starting, more heat energy is generated and the process continues in a cumulative way.

The weakened fuse may then fail arbitrarily during a starting operation. The motor remains connected to the supply on the other phases (so called "single phasing") but can not be plugged (electrically braked) and must be protected against excessive over-heating by the motor protective device.

Slight overloads of longer duration are also critical :

The load current flowing through the fusible link of the fuse in service heats it up to a relatively high temperature. If a fuse-link is loaded with its rated current for a longer period of time, the fusible link will be very hot and the surrounding quartz sand may form a molten mass with it. The surrounding filled with quartz sand is responsible for the actual cooling and quenching of the arc in a fuse, similar to the arcing chamber of the circuit breaker. After a certain ageing process, the sand particles lying immediately next to the fusible link are no longer loosely packed. If such a fuse-link has to handle a short-circuit, the cooling effect of the sand will be appreciably reduced. The arc inside the fuse in all probability will not extinguish fast enough and the fuse-link may explode.

For the above reason, it is recommended that the continuous loading of a fuse-link should not exceed about 75...80 % of its rated current. It is even sometimes recommended to change the fuses from time to time.

Continuous service at the rated current or frequent starting operations do not have any negative effect on the characteristics of the circuit breaker. From this point of view, it may be considered as free from ageing.

4.3.5. Reduction of the conductor cross-section

The cross-sections of the motor leads are selected on the basis of the rated current of the overload protective device connected upstream. If a fuse-link is chosen as the overload protective device, its current rating must be higher than the rated current of the motor (prevention of nuisance blow-up during the starting). The rating and the current setting of the circuit breaker, based only on the rated current of the motor, permits a smaller cross-section of the leads than in the case of the fuse.

Some of the national standards permit a higher current loading of the conductor protected by a circuit breaker than in the case of a fuse-link. The bimetallic thermal overload release reacts quickly even if the overload is relatively low. For this reason, the conductor can be utilised up to its ultimate thermal capacity.

With fuses, a factor of safety is always to be taken into account as according to the definition, a fuse has to blow up within an hour with an overload equal to 1.6 times the rating of the fuse. The circuit breaker has to trip at 1.2 times the current setting (IEC 364-4-43 : Protection of conductors and cables against excessive temperature rise).

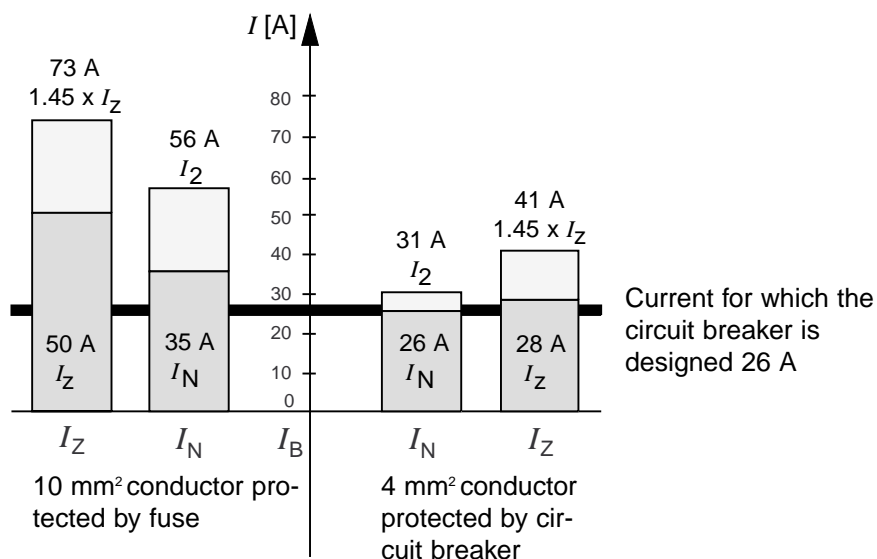

4.3-2: Utilisation of a copper conductor in accordance with IEC 364-4-43.
Graphical representation of the equation:

$$I_B \leq I_N \leq I_Z$$

$$I_2 \leq 1.45 \cdot I_Z$$

where : I_B " current for which the circuit is designed
 I_Z " continuous current-carrying capacity of the cable
 I_N " nominal current of the protective device
 I_2 " current ensuring effective operation of the protective device

The dark black bar shows the desired loading. If a fuse-link is chosen as the short circuit protective device, the minimum rating of the fuse will have to be 35 A. As the value of the test current I_2 (56 A) of the protective device must lie below the 1.45 times the current carrying capacity (Ampacity) of the conductor (73 A), a 10 mm² copper conductor is to be taken. The current setting of the circuit breaker, however, can be chosen equal to the actual operational current and will trip faster in the case of an overload. This principle of adjusted protection in this case permits a reduction of the cross-section of the conductor to 4 mm².

The condition $I_2 \leq 1,45 \times I_Z$ can sometimes lead to unexpected surprises, especially in the case of the fuses. Increased cross-section of the conductor is the result in most of the cases.

An example will explain the technical background of the situation:

Dimensioning of a 4mm²-multi-core conductor. Referring to the table 'Recommended values for the continuous current-carrying capacity of the cable I_Z and the corresponding overcurrent protective device for protection against overload (IEC 364-4-43)', the continuous current-carrying capacity of the cable for the above mentioned conductor is $I_Z = 28$ A (type of cable laying B2, multi-core conductor in electrical installation ducts in the wall or under the floor, 3 of the cores loaded). The expected operational current of the load is already defined to be 26 A. A part of the equation

$$I_B \leq I_N \leq I_Z$$

is thus already given.

$$26 \text{ A} \leq \dots \leq 28 \text{ A}$$

Hence, the expected operational current is smaller than the current carrying capacity of the conductor. Up to now, the selection appears to be correct.

Cross section [mm ²]	Max. current load I_Z [A]	Rated current of fuse-link [A]
1.5	15	10
2.5	20	20
4	28	25
6	35	35
10	50	50
16	65	63
25	82	80
35	101	100
50	-	125

Table Fig. 4.3-3: Recommended values for the continuous current-carrying capacity of the cable I_Z and the corresponding overcurrent protective device for protection against overload (IEC 364-4-43)', the continuous current-carrying capacity of the cable for the above mentioned conductor is $I_Z = 28$ A (type of cable laying B2, multi-core conductor in electrical installation ducts in the wall or under the floor, 3 of the cores loaded, copper, ambient air temperature 25 °C).

The fuse-links type gG taken as overload protective device, are graded in rated currents of 25 A, 35 A and 50 A in this current range. None of the fuses, however, has a current rating lower than the Ampacity of the conductor of 28 A and higher than the operational current of 26 A.

A conductor with a higher cross-section must be selected.

The next higher standardised cross-section is 6mm². Continuous current-carrying capacity of the cable $I_Z = 35$ A. For this conductor, only a 35 A fuse-link as overload protective device can be considered.

Now the condition

$$I_2 \leq 1,45 \times I_Z$$

is to be checked.

The test current I_2 of the fuse is equal to the 1.6 times rated current of the protective device, i.e. 56A. The 1.45 times the Ampacity of the conductor is 51A. For the 35A fuse-link, this would mean .

$$56 \text{ A} \leq 51 \text{ A}$$

which is an impossible condition.

The next higher size of conductor must be tried out, in this case 10mm². Ampacity $I_Z = 50$ A.

Checking again: $56 \text{ A} \leq 1.45 \times 50 \text{ A} = 73 \text{ A}$

The result : the installed cable 10mm², with a 35 A fuse-link and a load current of 26 A, is only loaded to 52% of its ultimate current carrying capacity.

Circuit breakers will reduce the installation costs as the current setting will be equal to the operational current. The test current I_2 will be equal to the 1.2 times the current setting. The condition that the value of the test current I_2 of the protective device must not exceed the 1.45 times the current carrying capacity of the conductor is automatically met. The conductor cross-section can be selected on the basis of the expected operational current ($1.2 \times I_Z < 1.45 \times I_Z$).

In the above example this means : with a load equal to 26 A and with the ultimate current carrying capacity of the 4mm² conductor equal to 28 A, the current setting of the circuit breaker must be exactly equal to 26 A (factor of utilisation 93 %, without exceeding the maximum permissible temperature rise of the conductor). Thus the condition $26 \text{ A} \leq 26 \text{ A} \leq 28 \text{ A}$ is fulfilled.

Another example :

To be able to carry a continuous motor rated current of 80 A and to allow a normal starting, a fuse-link rated at 125 A must be selected. This requires a conductor cross-section of 50 mm². If instead of the fuse, a circuit breaker with adjustable thermal overload release is chosen, a conductor cross-section of 25mm² can be taken (continuous current-carrying capacity of the cable I_Z conforming to the IEC 364-4-43, multi-core conductor in electrical installation ducts, ambient air temperature 25 °C).

4.3.6. Simplified planning of installations

The circuit breaker is a modern device. The compact housing permits different ways of fitting in the cabinet - they can be plugged-on, screw fitted or latched. The terminals are mostly protected against accidental touching or meets the requirements of the finger-protection in the region of manual operation and do not require any additional measures to prevent direct contact with the live parts.

The stray arc which may spread out during the very short breaking operation, can be easily controlled with simple measures. With the help of the door-mounted handle or a prolonged rotating knob, it can be comfortably operated from the outside of the cabinet.

4.3.7. Reduction of costs of installations and operational costs

Cost of installation for signalisation

With increasing degree of automation, more and more attention is being paid on the signalisation of the state of switching of the load feeders. For the integration of the state of the outgoing feeders in the information stream controlling the installation, auxiliary signalling contacts are necessary (on, off, overload, short-circuit). These information are easily communicated via the appropriate auxiliary contacts of the circuit breaker. In the case of the fuse, complicated electronic monitoring circuit or parallel-connected circuit breaker of lower current rating complete with signalling and tripping-indication contacts would be necessary.

Cost of remote control

Under given circumstances and with the help of additional equipment (magnet or motor drive), the remote control (switch on or switch off) of a circuit breaker is possible. Applications with low frequency of switchings (a few switching operations per day) or where a latched contactor would be normally required, a remote controlled circuit breaker with a motor drive could replace the combination of the fuse and the contactor.

The circuit breaker with remote control permits re-switching after a breaking operation from the operating console.

Cost of installation for segregating in compartments

An arc due to a short-circuit of a magnitude of about 10 kA, travels with a velocity of about 50 m/s (180 km/h) between two, blank copper conductors. To prevent extensive damage, the installation is segregated in compartments which limits the movement of the stray arc. The partitions must be very precisely finished as otherwise the root of the arc may pass through the small cracks and cause a re-striking of the arc at the other side of the partition. Effective segregation increases the cost of installation quite appreciably.

Quick acting circuit breakers interrupt the short-circuit currents of low to intermediate magnitudes faster than the fuse. Within the few milliseconds required for the clearing of the fault, the arc can travel only a few centimetres. The possible damage is limited locally and the degree of segregation can be reduced.

Operational costs

Only the cost of a fuse-holder including a set of fuse-links should not be compared with that of a circuit breaker. A circuit breaker must not be replaced after the interruption of an overload or of a short-circuit, provided of course that it is correctly rated.

The number of the set of fuse-links considered over a definite period of service affects the cost calculation. In certain sensitive process controlling installations where uncontrolled blowing up of the fuses is unacceptable and all the fuses are to be replaced with appreciable time consumption at each maintenance work, the cost advantage is definitely for the circuit breaker.

The cost calculations for the erection and operation of an installation must always be considered as a whole. The comparison of the circuit breaker and fuses can not be done only on the basis of the price of a set of fuse-links and only from the point of view of the erection cost of the installation. The space saving and in general the easier handling of the circuit breaker must also be considered for a serious comparison.

Down time costs

For the planning of an installations, the important factors to be discussed are the ease of service and maintenance, the accessibility of the different components of the installation and the arrangement of the various devices in relation to the load. One tends to forget the repetitive costs like those involved in the resetting or replacement of the protective device.

A comparison of the time needed for re-switching between the circuit breaker and the fuse will be in favour of the circuit breaker, especially if we also consider the time consumed for donning the stipulated protective clothing for the replacement of larger high rupturing capacity fuses.

Circuit breaker

- locate and rectify the fault
- re-switch

Fuse

- locate and rectify the fault
- find out the size of the fuse-link
- get the fuse-link
- replace the fuse-link
- re-switch

Reach us now at www.rockwellautomation.com

Wherever you need us, Rockwell Automation brings together leading brands in industrial automation including Allen-Bradley controls, Reliance Electric power transmission products, Dodge mechanical power transmission components, and Rockwell Software. Rockwell Automation's unique, flexible approach to helping customers achieve a competitive advantage is supported by thousands of authorized partners, distributors and system integrators around the world.

Americas Headquarters, 1201 South Second Street, Milwaukee, WI 53204, USA, Tel: (1) 414 382-2000, Fax: (1) 414 382-4444
European Headquarters SA/IV, avenue Hermann Debroux, 46, 1160 Brussels, Belgium, Tel: (32) 2 663 06 00, Fax: (32) 2 663 06 40
Asia Pacific Headquarters, 27/F Citicorp Centre, 18 Whitefield Road, Causeway Bay, Hong Kong, Tel: (852) 2867 4766, Fax: (852) 2508 1846

