

AD 651 556

C/64-10

RADIO AND TELEVISION IN THE SOVIET UNION

F. Gayle Durham

Research Program on Problems of International  
Communication and Security

Center for International Studies  
Massachusetts Institute of Technology  
Cambridge, Massachusetts

June, 1965

MAY 17 1967

**BEST  
AVAILABLE COPY**

## Table of Contents

### Prefatory Remarks

I.	The Broadcasting Network.....	1
	A. Radiobroadcasting.....	1
	B. Broadcasting Stations.....	6
	C. Television Broadcasting.....	8
	D. Number of Television Stations.....	13
	E. Radio and Television in Rural Localities.....	15
II.	Production and Repair of Radio and Television Sets.....	21
	A. Radio Sets.....	21
	B. Television Sets.....	29
	C. Future Radio and Television Sets.....	34
	D. Subscription Fees.....	41
	E. Repair of Radio and Television Sets.....	42
III.	The Administration of Soviet Radio and Television.....	47
	A. Structural Apparatus of the Broadcasting Administration.....	47
	B. Functions of the Administration.....	50
IV.	Programs and Hours of Broadcasting.....	54
	A. Radio.....	54
	B. Television.....	57
	C. Educational Television in the USSR.....	59
	D. Radio and Television in Dnepropetrovsk, Ukrainian SSR.....	62
	E. Recording of Broadcasts.....	64
V.	INTERVISION.....	68
VI.	The Soviet Audience.....	74
	A. Size of the Audience.....	74
	B. Nature of the Audience.....	75
	C. Audience Feedback and Listening Behavior.....	77
	Notes.....	88

Maps, Tables and Diagrams in the Text

Diagrams

Structure of Soviet Radio Broadcasting-Reception  
Network.....opposite page 1

The Structural Apparatus of the Administration of  
Soviet Radio and Television.....51

Maps

Radiobroadcasting Stations, USSR, 1963.....7

Television Broadcasting Stations, USSR, 1963.....14

The INTERVISION Network, October 1, 1960.....72

The INTERVISION Network, January 1, 1963.....73

Table

Time Spent Watching Television by Personnel of the  
Kirov Plant Tool and Die Shop, Leningrad.....87

## Appendices

### 1. Data on Broadcasting and Receiving Networks

- A. Number and Types of Receiving Sets, 1959-1963, by Union Republic
- B. Number of Receiving Sets Available for Sale to the Soviet Population
- C. Production of Receiving Sets, USSR
- D. Comparison of Official Figures on Radio and Television Sets: Produced, in Existence, and Available for Sale to Total Population
- E. Number and Type of Radiobroadcasting Stations, USSR, 1963
- F. Number of Television Centers in the USSR, 1952-1962
- G. Television Studios in Operation in the USSR, 1959
- H. Wired Sets in Rural Localities 1959-1961
- I. Distribution of Television Channels by Television Centers, USSR, (as of August, 1962)
- J. Distribution of Frequencies on Television Channels Used in the USSR
- K. Characteristics of Some Types of Soviet Radios

### 11. The Structure of the Administration of Radiobroadcasting and Television: Supplementary Materials

- A. The Leningrad Committee on Radio and Television
- B. The Moscow Television Studio: Structure of Administrative Apparatus

### 111. Programming in Soviet Radio and Television

- A. Broadcast Content and Frequency, Before and After October 15, 1962
- B. Wave-Length Table of Pre-October 15, 1962 Schedule
- C. Quantity of Radiobroadcasting, Union Republics, 1959
- D. The Overall Volume of Television Broadcasting in the USSR
- E. CST Program Schedule by Category, Number of Broadcasts, and Broadcast Hours (January through June, 1960)
- F. Program Schedule of Radio and Television Programs for March 23, 1964 (Monday) in Moscow

### IV. Audience

- A. Number of Persons Per Wired Set, 1961
- B. Number of Persons Per Wave Set, 1962

### Prefatory Remarks

This paper is one of a series of three reports based on recent research on mass communications media in the Soviet Union today.\* It is an attempt to bring together most of the information on Soviet domestic radio and television broadcasting systems gathered during the course of that research. The notable exceptions are amateur radio, news-broadcasting (both covered on separate reports) , training and education of personnel, Soviet foreign radio-broadcasting, and foreign radio listening among the Soviet population.

Sources used include the following: several main organs of the Soviet press (including PRAVDA and IZVESTIA) for the years 1957-1964; trade journals of radio and television industries; articles and books of Soviet and Western publication dealing with the subject; research notes from Radio Liberty; and the author's personal experience during a six-month's residence in the USSR during 1964. All source materials used are open ones, although some are of limited distribution.

Cambridge, Massachusetts

March, 1965

---

\*The remaining papers are, News Broadcasting on Soviet Radio and Television, and Amateur Radio in the USSR by the same author.

The research for this paper was sponsored by the Advanced Research Projects Agency of the Department of Defense (ARPA) under contract #920F-9717 and monitored by the Air Force Office of Scientific Research (AFOSR) under contract AF 49(638)-1237.

Diagram I.

Structure of Soviet Radio Broadcasting and Receiving

Moscow: Wired network receiving broadcast by means of antenna

Moscow: Wired network with wire connection to broadcast station

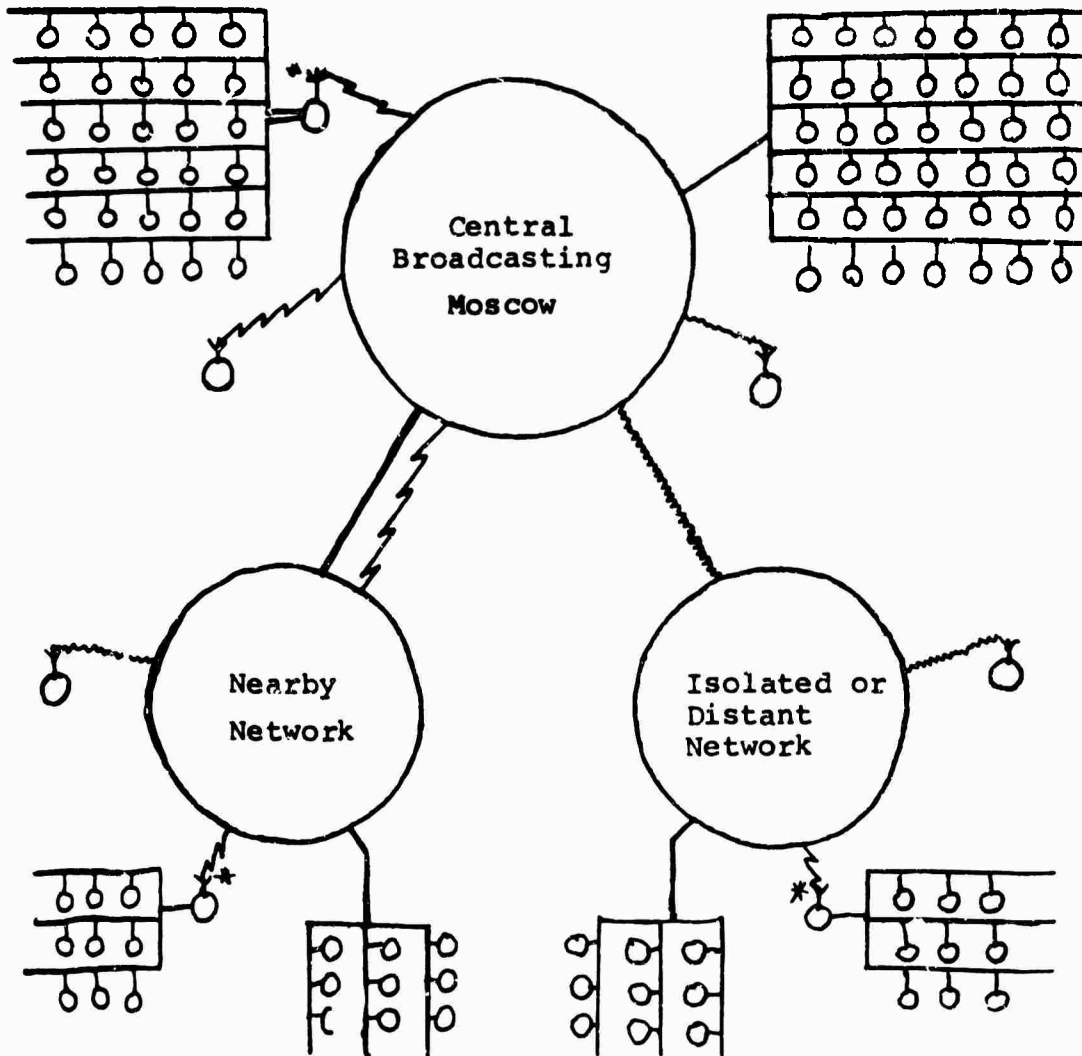

Key to Symbols:

- wired plug-in receiver (radio-tochka)
- ⊙ wave receiver (radio-priyomnik)
- ⚡ on long, medium wave
- ⚡ on short wave
- wire (provodniy)

\* Single Diffusion Exchange (Radio-uzel)

- May include:
- a. editor
  - b. amplifier
  - c. public address system
  - d. factory
  - e. individual home receivers

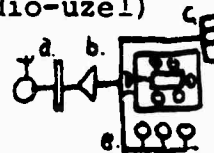

## I. The Broadcasting Network

### Radiobroadcasting

The structure of Soviet radiobroadcasting has remained basically the same as that described by Alex Inkeles in his book of 1950, entitled Public Opinion in Soviet Russia: A Study in Mass Persuasion.<sup>1</sup> Transmitters operate at three levels, the highest of which is Central Broadcasting in Moscow. Transmission from Moscow Central is by long or medium wave to Moscow and nearby networks, by short wave to isolated networks and individual sets, and by wire to urban and suburban Moscow and to networks in close proximity to Central Broadcasting's main transmitter. Local broadcasting at the republic and regional levels is gathered into zonal networks, all of which are part of the national network; programs are received from Central in Moscow either by wave or by wire, and sometimes by both. The lowest level of radiobroadcasting is the radio diffusion exchange (radio-translyatsionniy uzel), sometimes called the radio-uzel, which is a wired network. Its chief function is to receive broadcasts, usually by wave, from the Central or local network, and transmit programs to the home wired speakers, by means of wire. The diffusion exchange may possess a phonograph, microphone, and other equipment with which it can originate programs of its own; this allows the addition of local features to the day's broadcast schedule. These



programs which originate at the radio-uzel never actually go "on the air," of course, but move entirely over the wired net in a limited locality. A public address system may also be fed into the same wired net as the speakers; these loudspeakers of the public address system may be located in public squares, factory shops, and so on.

The speaker in the wired net is called a radio-point (radio-tochka). It consists largely of a transformer, a speaker, a volume control, and a switch. It, therefore, can receive programs only by means of wire, and can be regulated only by volume or on-off switch. Until recent years, there was no selection apparatus, since only one program could be broadcast over the wired network at one time. In April and May of 1962, however, there began to appear announcements concerning the institution of multi-programming on wire.<sup>2</sup> The multiple system of programming is received on an ordinary loudspeaker or radio-tochka to which is attached a special selector device. Moscow, possessing the largest wired network in the country, with over 1,500,000 radio-points, was the first locality to receive the new system on a large scale, though it has also been used in Riga, Latvia, in Ashkhabad, Turkmenia, and in the Uzbek Republic. The extension of the system is planned to cover eventually the whole of the Soviet Union, thus providing some power of program selection even for those who do not own wave sets.

The wave receiver has shown a sharp increase in quantity

during the past ten years. In 1953, the number of wave sets was only half that of wired speakers, while at present their quantities are approximately the same. This leads us to a discussion of the whole system of wired broadcasting, and why it has been for so long the predominant system of radiobroadcasting in the Soviet Union. The reasons for the institution of the system which have been put forth repeatedly by the Soviet leaders may be summarized as follows: (1) wired broadcasting is more economical; (2) better reception is obtained by means of wire; (3) wired sets may carry programs originating at the diffusion exchange, making possible the use of radio as a purely local means of communication; and (4) propaganda via radio can be almost completely controlled. While these reasons on the surface may appear persuasive, the matter is somewhat more complicated when viewed at depth.

Wired sets may be considered economical only as an initial investment. When the regime first began to develop a communications network, it was immediately expedient to utilize telephone lines for telephone, telegraph, and wired radio communications. The installations for broadcasting were cheaper than those for wave broadcasting. With the enlargement of the radio network, however, the use of wires became less economical, due to more complicated connections and maintenance procedures. In addition, the development of multi-program broadcasting on wire further complicates the equipment, since it requires additional selection appa-

ratus, either at the diffusion exchange, or at the loudspeaker itself. This equipment renders the entire receiving apparatus more complicated, and hence, more costly, than wave reception equipment. Depreciation is greater, and maintenance becomes a constant burden to the radio-electronics engineers and technicians. These factors have considerably complicated and slowed down installation of multi-programming. Added to the other technical difficulties of Soviet broadcasting, this situation would seem to impart a distinctly uneconomical quality to the system of wired broadcasting in a modern context. In addition, the average person prefers to purchase a wave set which provides more selection and costs no more. Further, a wave set may be purchased on credit, and the selector attachment must be paid for immediately.

Although it is claimed that better reception can be obtained by wire, in actual fact this is true only when receivers of first-class quality are used. Widespread indications are that, in the process of trying to radiofy the country as rapidly as possible, speakers of third-class quality were used. Reception on this grade of receiver is roughly comparable to that on a crude public address system. The last two reasons, that of local origin for programs, and propaganda control, can obviously act to the detriment of domestic communications should the radio network be seized by an enemy in wartime. Control over Soviet communications would be much more complete under such a system. Whether

or not the above considerations have occurred to and persuaded those responsible for Soviet communications development policies, the practice of maintaining a numerical supremacy of wired over wave receivers seems rapidly on the decline. The figures in Table I. A. (Appendix One) indicate the comparative numerical strengths of the two types. This comparison shows that the number of each type of sets was approximately the same in 1963.

FM broadcasting in particular is slated to become more prevalent in the USSR, as it is in other European countries. A former Chairman of the State Committee on Radio and Television, Kaftanov, explained its increase thusly:

FM broadcasting is to a large degree free of the inadequacies which are inherent in AM broadcasting on the long, medium, and short wave lengths, since it is almost entirely free of static interference. Frequency modulation in the ultra short wave range assures high fidelity, due to the fact that it is possible to broadcast a wide range of audio frequencies (from 30 to 15,000 cycles per second) without distortions. A large scale development of ultra short wave broadcasting is one of the ways to improve and expand local broadcasting inasmuch as, with the broadcast of the Central program, it permits the organization of high quality broadcasts by the oblast and republic radio without interfering with the Central programs.<sup>3</sup>

In addition to Mr. Kaftanov's stated reasons for the expansion of FM broadcasting in the USSR, there are two underlying considerations for this policy. One is that FM broadcasting, reliable only for short distance broadcasting, has the same quality as the loudspeaker in regard to range. The second is that the development of a local system of

broadcasting may be partly in deference to widespread complaints in the Soviet Union during the past several years, that all wave lengths and systems carried the same programs, and little, if any, variety was available. The addition of local alternatives should help to alleviate this problem.

The increase in FM broadcasting is facilitated by commensurate growth of the television network:

In view of the fact that radiobroadcasting ultra wave FM transmitters are identical with the transmitter broadcasting the sound portion of the television programs, it is possible to install ultra short wave FM transmitters at television broadcasting stations which could use antenna supports in common with the television transmitter, as well as the same power supply system and to conduct both ultra short wave FM and television at the same time, without major capital investments.<sup>4</sup>

By the middle of 1959 there were approximately 60 such transmitters; in 1963, the number had reached approximately 86 for the entire USSR.<sup>5</sup> In regions which have a thinly scattered population, the creation of FM stations is deemed economically unfeasible, and in these regions it is planned to extend radio coverage through construction of stations operating on long, medium and short waves.

#### Broadcasting Stations

As concerns the stations themselves, there were, as of 1961, five classes of new typical radiobroadcasting centers (or Houses of Radio) as stipulated for construction during the then current Seven-Year Plan. Of these RVU (radioveshchatelnyy uzel), the largest is the first class,

Map I. Radiobroadcasting Stations, USSR, 1963

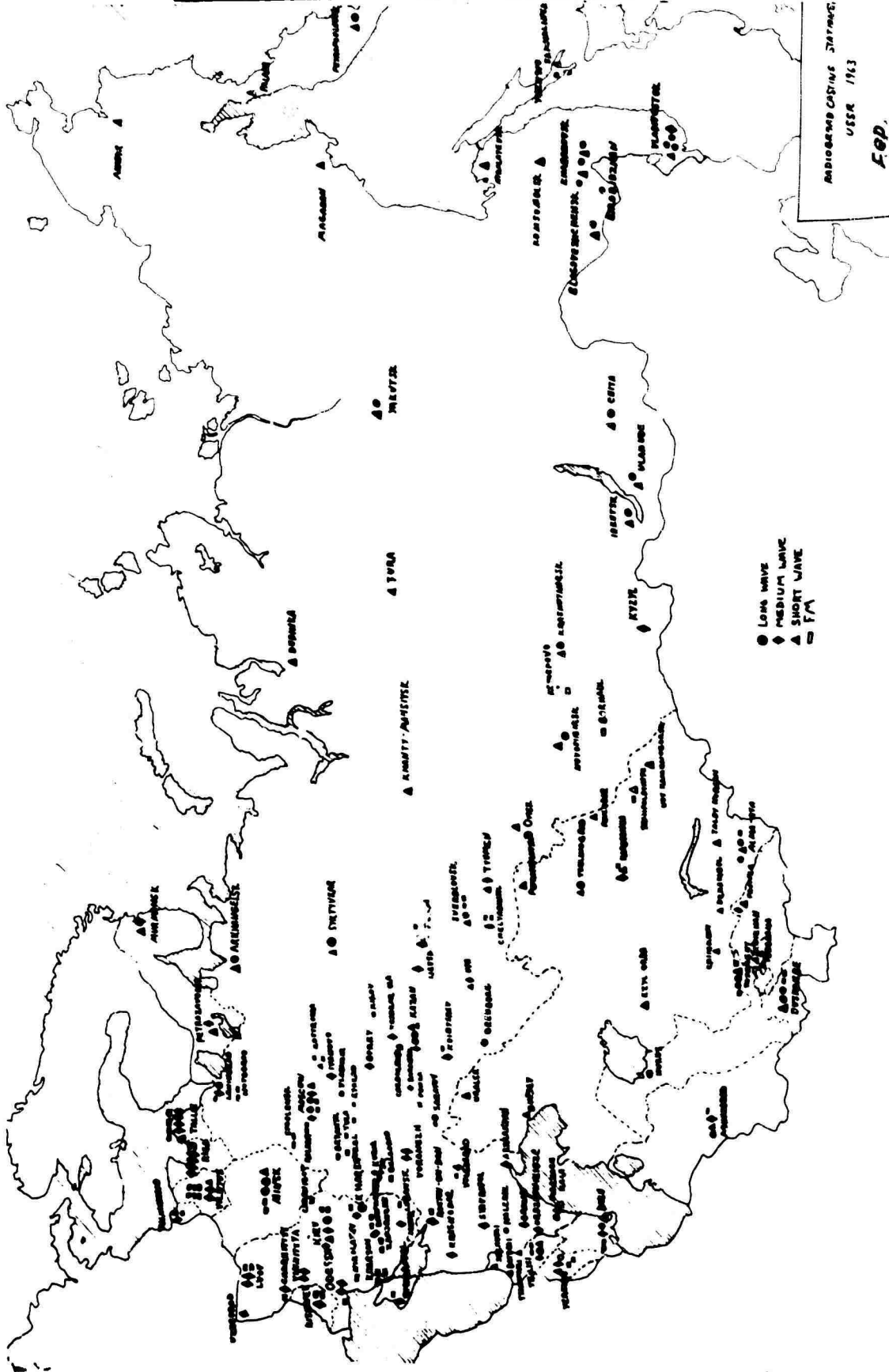

(Adapted from Radio Liberty Map of April 1963. F.T.D.)

RVU. It is designed for radio committees operating for 10 hours or more a day, and employing a staff of over 100 persons. Rather large in size, it includes six different radio studios, among which is a large speech studio of about 15 to 20 square metres. Also included are a large concert studio (300-350 square metres), 20 equipment units for radio-broadcasting and sound recording, and a corresponding number of necessary production, technical, and editorial areas and services. The smallest radiobroadcasting center, the RVU-5, is planned for cities where the committees or editorial boards on radio employ a staff of up to 20 persons, and broadcast up to 1.5 hours per day. It consists of two studios, one for music, and one for speech, and two equipment areas. The volume of the RVU-5 is 2,300 cubic metres, and its area is 400 square metres. The volume of the RVU-2 is 12,000 cubic metres, that of the RVU-3, 6,000 cubic metres, and that of the RVU-4, 3,000 cubic metres.<sup>6</sup> It should be stressed, however, that these studios are ideal, model studios, and do not necessarily represent the ordinary broadcasting conditions of Soviet radio. Of equipment in older, less centrally located stations, we have little indication.

#### Television Broadcasting

At the present time (1965) in the Soviet Union there are about 100 program centers for television broadcasting, 32 powerful relay stations, and about 250 relay stations

of low power (up to 100 wt).<sup>7</sup> These television stations cover an area populated by more than 90,000,000 persons, as compared to the total population of the USSR, now about 220,000,000. There are at present more than fifty large cities which are regularly receiving Moscow Central programs. Other areas, of course, receive occasional broadcasts originating from Moscow, by means of their local network.

The standard equipment for television studios as of 1961 was described by the then Chairman of the Committee on Radio and Television, Kaftanov:

Television stations in krai and oblast cities are equipped with the standard TV and ultra-short wave station, with a picture transmitter of 2.5 kilo-watts, television equipment of a film-broadcasting and mobile television station, four ultra-short wave broadcast transmitters with frequency modulation. Such a television center has two studios, a basic one (300 square metres in area), and a model-announcers' one (40 square metres). The height of the tower together with the antenna is 192 metres. The radius of broadcast is 50-60 kilometers and more.

Television stations of capitals of republics have a power of 15 kilo-watts...with the help of low-powered relay stations it is planned to raise the radius of broadcasts...<sup>8</sup>

Although the television centres at Moscow, Leningrad, and Kiev are not typical of those throughout the Soviet Union, they are the most important centers of the television network, and thus merit detailed description. In Leningrad there has recently been under construction a new television center, the transmitting station of which is located in a separate building with an adjacent tower of 300 metres



The main building houses six studios with areas of 600, 450 (color TV), 300 square metres, two studios with areas of 150 square metres, and an educational channel studio of 200 square metres.<sup>9</sup> The director's control equipment is also located in the main building, as are the technical control and monitoring equipment for the picture and sound channels, motion picture photography equipment, and other central services.

There are three large rehearsal studios. The second floor houses laboratories, equipment, and the third floor administrative offices and a study room.

One new tower, built in 1964, is 160 metres tall. Nearby is the main Leningrad television tower, which is 316 metres, 27 cm tall. Its base is 60 metres. At the 200-metre level there is a three-story "house" containing technical equipment. Its area is 300 square metres. The tower was constructed at Zaporozhe, a center for television equipment. The effective radius of the tower, which has four antennae with varying wave lengths, is 200 kilometres (as compared with the smaller tower having a 60-70 km range.<sup>10</sup>

In Moscow, there has been a good deal of reconstruction of television studios, as well as the beginning of construction of a new national television center. In the early 1960's three new television studios with areas of 600, 180, and 150 square metres were built; they include control equipment and the central transmitting apparatus. Television

motion picture projection equipment for 16 mm and 35 mm films was also installed here.<sup>11</sup> As of 1961, the Moscow television center had five mobile television studios, two stationary and twelve semi-stationary relay points. Planned for the projected economic period (1959-1965, the Seven-Year Plan) was a new television station with three transmitters, two for black-and-white broadcasts, and one for color. One of the notable features of the new station is its 500-metre reinforced concrete tower, which contains a number of technical shops. The tower has a diameter of 65 metres; the reinforced concrete sector of the tower is 400 metres high, while the metal portion of the structure is 100 metres. The tower supports both television and FM transmitting antennae, the radius of broadcast of which is 110-120 kilometres.<sup>12</sup> The newly planned National Television Center is to be situated in Moscow at Ostankino, near the USSR Exhibition of Economic Achievements. The project provides for ten main television studios, each ranging from 150 to 1,000 square metres in area. The studio building should be about 400 metres long. When completed, the television center should be able to broadcast 50 hours per day. The target date for the completion of the center is 1967--the Fiftieth Anniversary of the October Revolution.<sup>13</sup> Before that time, at the end of the current Seven-Year Plan, it is anticipated that there will be in existence approximately 180-190 program centers, 60 powerful relay stations, and about 350 relay stations of low power.<sup>14</sup>

The Kiev television studio in the capital of the Ukrainian SSR, has been in operation for thirty years. There are presently in use two studios, one 180 square metres in area, the other 300 square metres. A third studio of medium size, needs equipment and will soon be in operation. The tower is 190 metres tall. There are two transmitters, one having a range of 100-110 km, the other 60 km. The studio has two mobile broadcasting units which operate on different frequencies for simultaneous broadcasting.<sup>15</sup>

Color television is still largely in the experimental stage. Although color television broadcasts were begun on an experimental basis on November 5, 1954,<sup>16</sup> they were not carried out on a large scale until 1959. The experimental system used is a compatible one, in which broadcasts may be received either on a conventional or color set, much the same as in the United States.

A few hundred sets are in use in Leningrad, most of them located in group listening circumstances. Programs are broadcast in color in Leningrad for two hours each Saturday. Although the system used is essentially the same as that in widespread use in the United States, no system has been officially adopted, in order to avoid waste involved in any change which might come as a result of the Vienna conference this Spring.<sup>17</sup>

Although it may be possible to purchase color television sets, they are prohibitively expensive, and not

available on a widespread basis. Most Soviet citizens seem to regard color television as still a thing of the future, even in Moscow.

Descriptions of television stations elsewhere in the Soviet Union are not available, but one may safely assume that they are on the whole not quite as up to date, nor as impressive as those in Moscow and Leningrad. Most inter-city connections between stations are by means of relay towers; coaxial cables are used for only a few limited lines. The first link to Siberia, for example, was opened in May, 1963, by means of a chain of relay towers through Sverdlovsk and Kurgan. Smolensk is connected to Moscow by a series of eight intermediate receiving and broadcasting relay towers situated 40 to 50 kilometers apart. Each station has a tower from 70 to 100 metres tall. This may be considered a fairly typical linkage for the European part of the country. Fully automatic relay stations are expected to become widespread; the relay station will be switched on and off by means of a signal from the television station from which the program is being relayed. Remote control is expected in the near future.<sup>18</sup>

#### Number of Television Stations

The map on the following page will clearly illustrate the extent of the television network in the Soviet Union. Table I.G., taken partly from a Soviet publication,<sup>19</sup> will give the reader some idea of the characteristic features of

Television Broadcasting Stations USSR, 1963

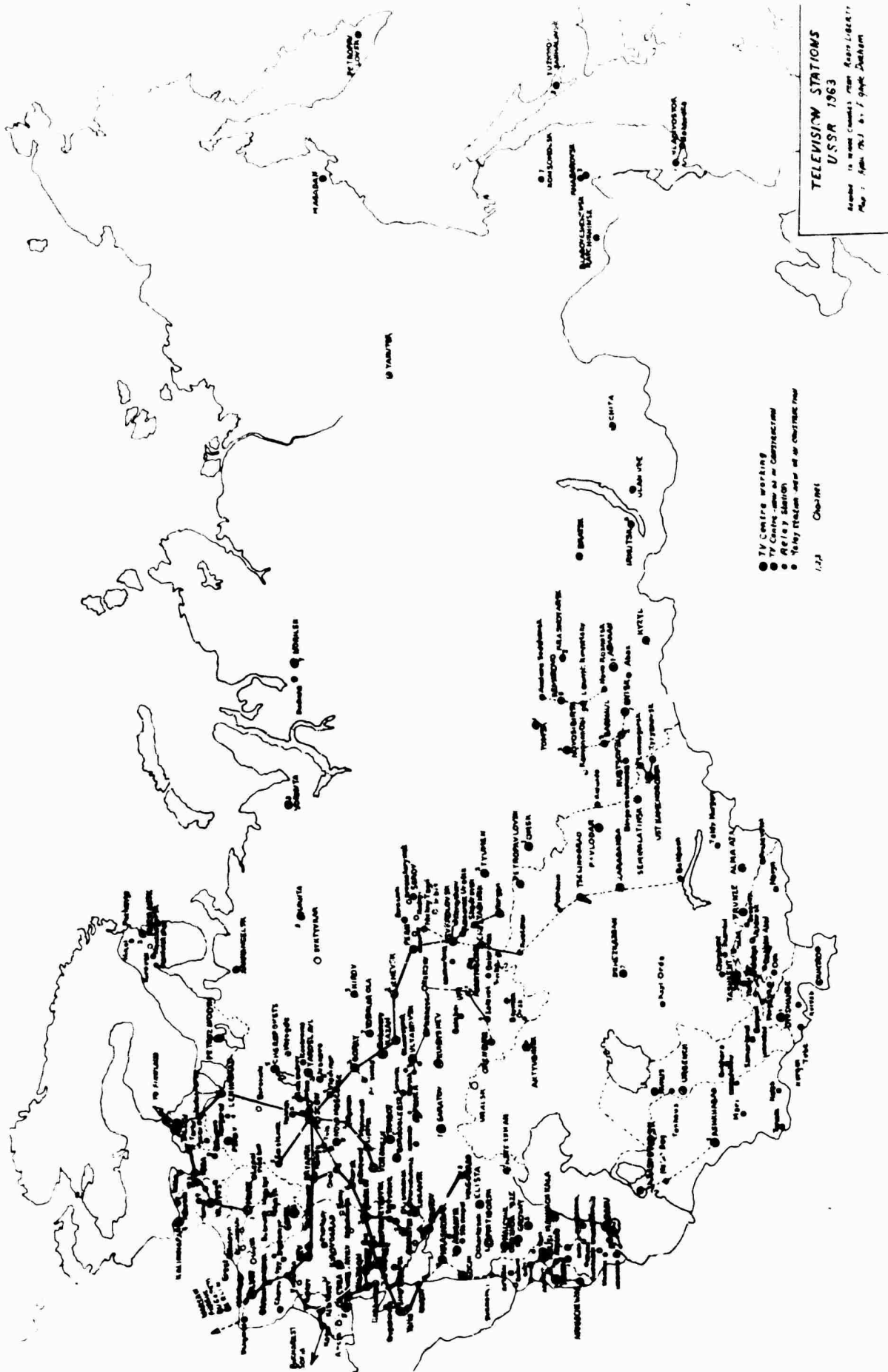

(Adapted from Radio Liberty Map of April, 1963. F.G.D.)

the television stations, although the information pertains to 1959, and is thus out of date in regard to the number of stations listed.

While the development of the television broadcasting network has been rather rapid in general, it has shown a definite lag in some republics. Although, as one would anticipate, these lagging areas are mostly in sparsely populated areas, this is by no means exclusively the case. Byelorussia, in the European part of the country, is a case in point. According to L. Kostyushko, member of the Committee for Radio and Television in Byelorussia, one reason for this lag is the low level of capital investment. Because of poor, outmoded equipment, the radius of broadcasting is quite small, and as late as June, 1962, covered only one-sixth of the territory of the republic.<sup>20</sup>

#### Radio and Television in Rural Localities

In the years since the death of Stalin, there has been great emphasis upon, and vast improvement in, the area of rural radiofication. During the years 1954-1957, more than 4,000 collective farm radio receiving systems (wired) were installed. During these years, about 7,500,000 plug-in sets were provided on collectives, and the number of radio receivers and television sets increased from 900,000 to 2,223,000 or almost two and one-half times.<sup>21</sup> In 1960, in the rural localities of the Russian Republic, there were

approximately 8,620,000 plug-in sets, and 1,877,000 wave sets.<sup>22</sup> Apparently, these figures are indicative of the relative proportions of wave sets to wired ones in rural localities. Most families have to be linked by the wired network to radio-uzel of the community for purposes of intra-farm communication, since both state and collective farms are becoming much larger due to mergers, and more extensive communication networks are needed for the daily managing of the farms. Kostrom Oblast is an example of the rapid radiofication of the country. In less than one year, 521 collective farms of the oblast were radiofied, resulting in a complete radiofication of 23 out of 28 regions.<sup>23</sup> As for wave sets and television receivers, growth has been much slower, but has nevertheless been steady. In 1962 alone, rural residents acquired 1,800,000 radio receivers and television sets through consumers' cooperatives (apparently the main means of rural distribution of consumer goods).<sup>24</sup>

It is however, evident that even wired radiofication has not been uniformly rapid, the notable exceptions being Azerbaidzhan, Moldavia, Latvia, Lithuania, and Kirghizia. In most of these republics less than half of the collective farms have radios, and in Lithuania only 26 per cent of farms have wired systems.<sup>25</sup> The reasons for the slow installations seem to be directly linked to acute equipment shortages. Part of the blame for these shortages has been placed upon the communications agencies, for not enlisting the aid

of the local industries in producing the needed materials in short supply. In a planned economy, however, such local adjustments are difficult to make. Impromptu manufacturing of items leads to serious shortages in the fulfillment of the production quota of the factories involved. Fear of attempting new models is reflective of this more basic caution against over-extending the production facilities of the local industries. It was reported that in 1958 the VEF Plant in Riga had produced a remote-control device for rural radio receiving systems. The plant, however, together with the Latvian Economic Council, delayed the production of this device. The Muron Plant designed a rural radio receiving system which used conductors, but was slow in making experimental models of the system, and refused for some time to put it into series production. The Riga Diesel Plant delayed two years in the development of automatically controlled diesel motors for use as power plants for radio facilities. The situation was still worse as regards designs for ultra-short (FM) receivers using semi-conductors, which were needed for use in low-lying and mountainous regions of the country, where cable transmission was not practical. The radio installation plan in Latvia in 1958, therefore, was only 54 per cent fulfilled. Since communications agencies were forced to make the necessary items by non-industrial methods, they were forced to make them in very limited quantities.<sup>26</sup> The supply of radio parts to rural radio owners



is also lagging. Consumers' cooperatives are constantly plagued with complaints that batteries and tubes could not be bought.<sup>27</sup> In some towns, such as the corn-producing town of Sushinov, there was no electricity, hence no radio until 1961.<sup>28</sup>

An example of the situation concerning radio and television on a collective farm may help to make the tables and statistics more real to the reader. The example which we have at our disposal is that of a collective farm of "average" size, located in the Ukraine near the town of Dnepropetrovsk. The farm covers an area of about 3,000 hectares (approximately 7,200 acres). On the farm live and work 1,100 persons in 600 separate households. Since there are only 12 trucks for the use of the farm workers and two cars for the exclusive use of the farm chairman, the use of mass media becomes an especially important means of communicating with the community outside of the farm. Because of the size of the farm, radio is also used as a means of communication between the administration of the farm and its members. The farm has its own radio-diffusion exchange, which receives broadcasts from the local network in Dnepropetrovsk and broadcasts them to the home speakers, of which there is one in almost every household. At the diffusion network the farm sometimes adds local features having to do with farm production, goals, and so forth; the farm chairman frequently speaks to members of the farm over the exchange. There are radio sets in about half of the farm

households. An exact proportion of the number of television sets to population was not obtained. Indications were that there were quite a few sets on the farm, but "not, of course, enough to go around." This is probably a fairly unusual farm in this respect. Television is still a fairly rare phenomenon on most farms. Programs are transmitted from Kiev and Dnepropetrovsk; often programs from Moscow can be seen via the Kiev stations, but this is not done on a regular basis.<sup>29</sup>

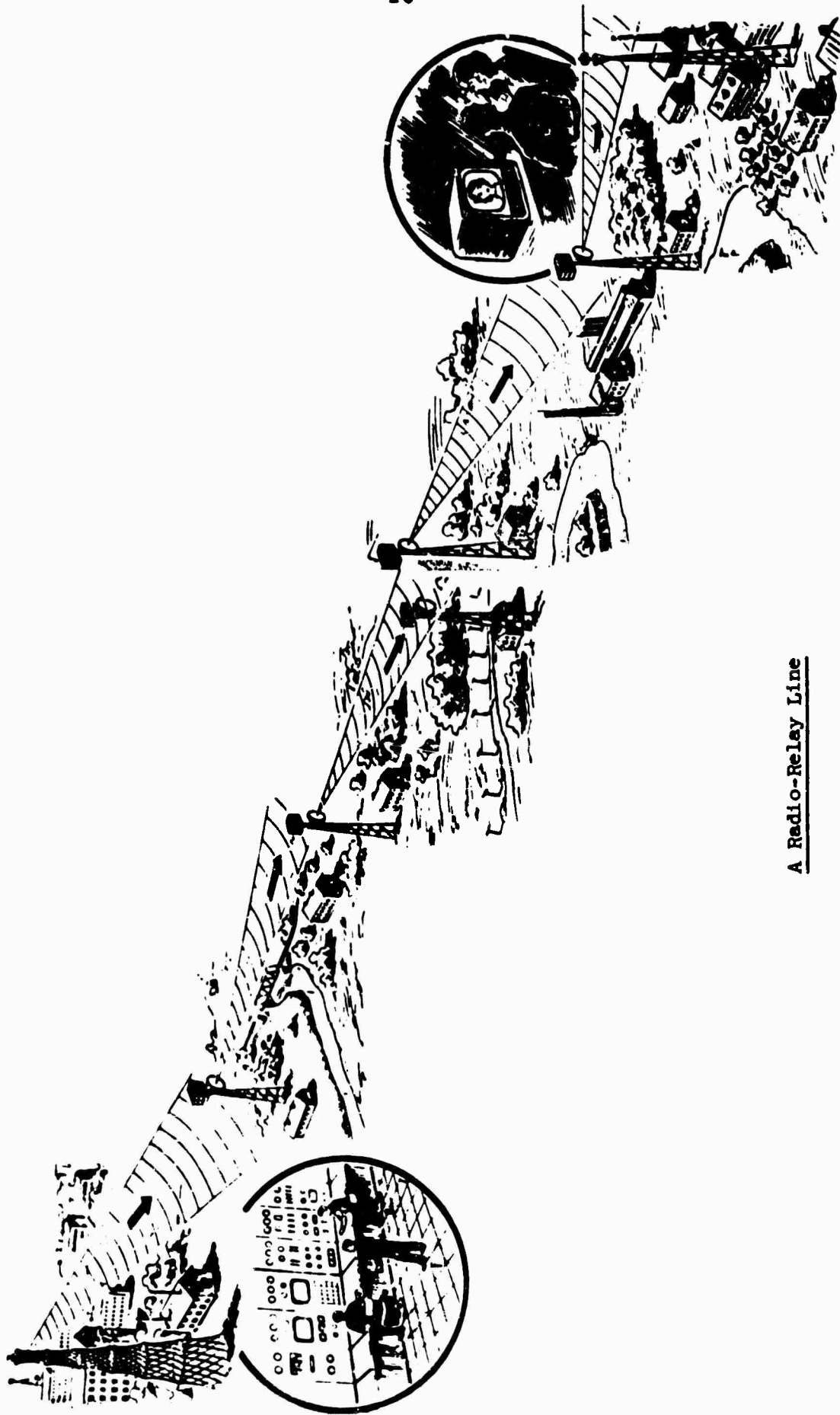

A Radio-Relay Line

## II. Production and Repair of Soviet Radio and Television Sets

### Radio Sets<sup>30</sup>

From a technical standpoint, Soviet radio sets are fairly well designed, although defective assembly often leads to breakage and the necessity for frequent repair. Table models almost always have a long wave band, a medium wave band, and often several short wave bands, although since 1958 no sets have been manufactured for internal distribution having short wave bands of less than 25 metres. These table sets are usually quite bulky and old-fashioned by contemporary American standards, resembling table models produced in this country about twenty-five years ago. Attempts to modernize appearances have tended more towards making sets of plastic and using long, simple lines, rather than reducing the size of the sets. Wired speakers are currently being manufactured in rectangular shape, made of black, yellow, or some other bright plastic, and closely resembling more modern American wave sets. Radio-phonograph and radio-tape recorder combinations, having the same bands as described above, are extremely popular, perhaps because of space limitations in most Soviet apartments.

Very popular at the present time are small transistor portable radio sets.<sup>31</sup> Most of these are made of bright-colored plastic, sold with an optional leather or simulated leather case. Such sets are almost never made of metal, since this is considered aesthetically displeasing, supposedly

because it resembles a professional or military radio set. Most portable transistor sets have a long wave band and a medium wave band. The cheapest set of this variety costs about 2 rubles, or 30 dollars. The more features a radio has, however, the higher its "class" designation. Third class is the poorest quality set, and First class and "Higher" or "Non-Class" sets are superior and most expensive. Such is the receiver "Spidola," which is without a doubt the most popular radio set in the Soviet Union today. Weighing about 5 kilograms (depending which of the two types of batteries one uses), this set, made in Riga, is very difficult to obtain; demands for it always exceed its production, and one almost never sees a "Spidola" on sale in a store. The "Spidola" which is produced for internal consumption, selling for about 75 rubles, has seven bands, including long wave, medium wave, and five short wave bands, going down to 25 metres. There is an export model of the "Spidola," however, which sells for about 110 rubles, which has short wave meter bands down to 13 metres. In line with existing lines of "informal distribution" of products in Soviet life, citizens within the Soviet Union sometimes obtain export models of the "Spidola" and sometimes resell them for a higher price. It has been reported that a new short wave receiver is shortly to be distributed, which is called the "Transistor-10." Although the exact characteristics of this set are not known to the author, rumors are that it will rival the "Spidola" in popularity.

The smallest set available for sale is the "Kosmos," a tiny, long or medium wave receiver about 2 1/2 inches square. This

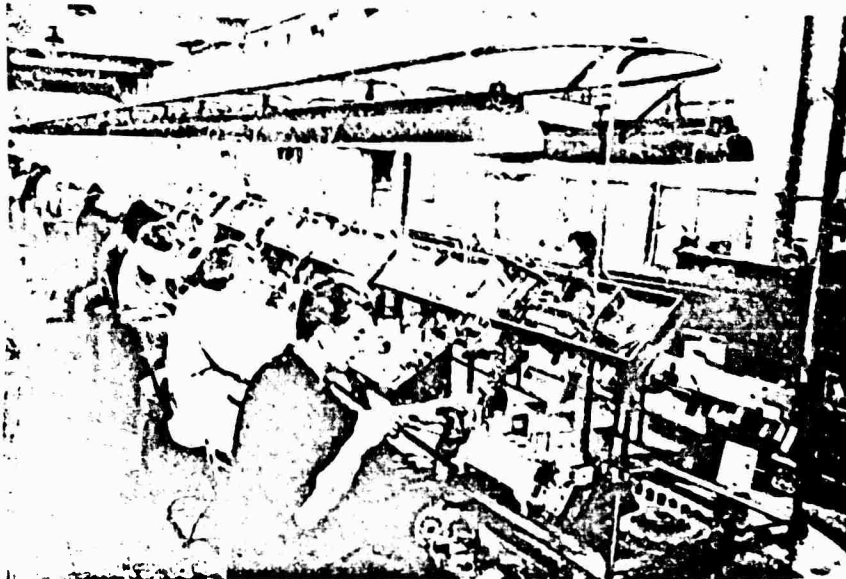

The Popov Radio Factory in Riga. Conveyor Assembly of the radio receiver "Festival" (1959.)

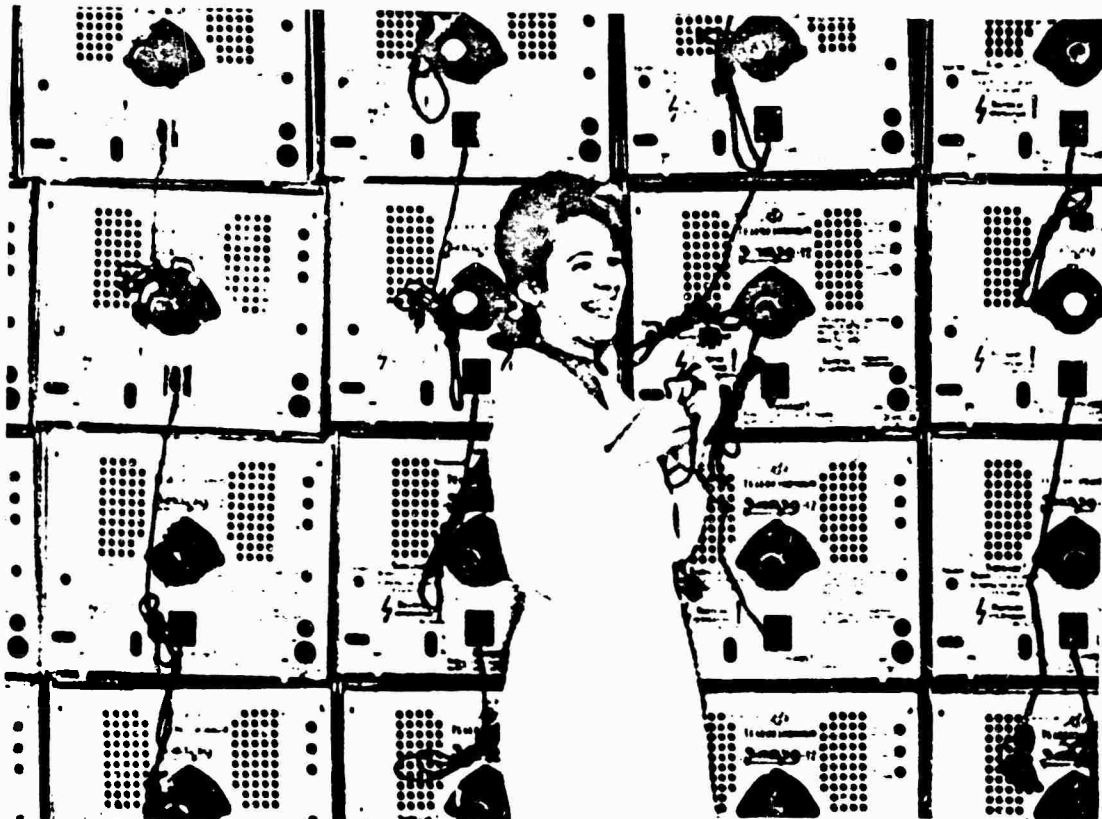

Television manufacturing. Girl is checking rear assembly of television sets. (The model being checked is the third-class "Rekord")

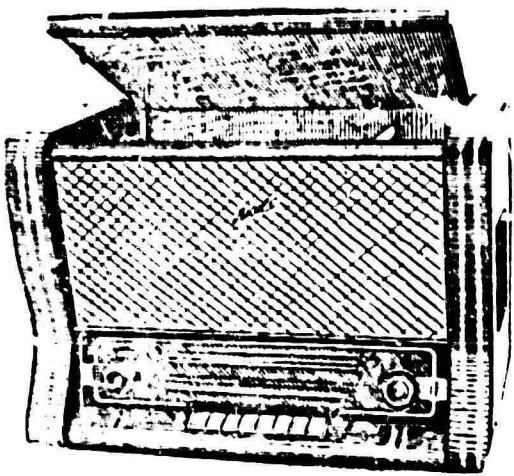

Radiola "Lyuks"

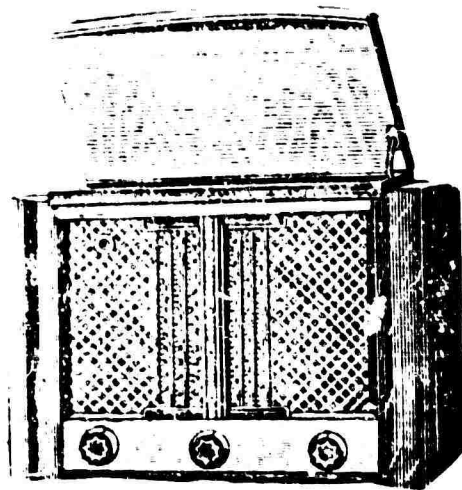

Radiola "Mir"



The Portable Radiola  
"Kazan"

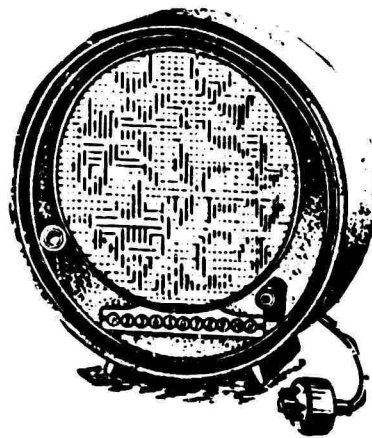

The "Luch"

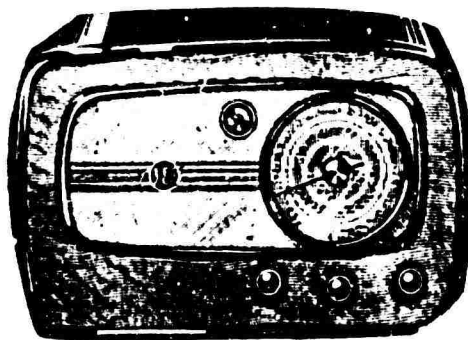

The BEF M-557

1.

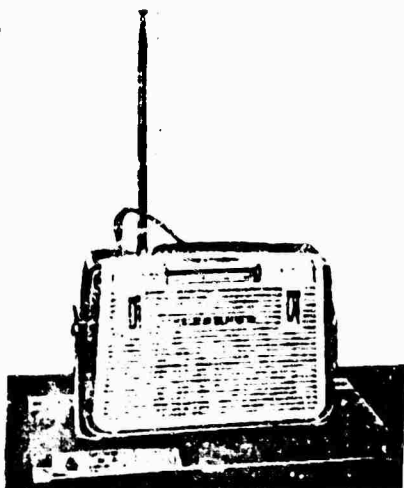

2.



3.



Current models of some Soviet transistorized radio sets. 1. The "Spidola," one of the few post-1958 models equipped for short-wave reception below the 25-metre band 2. The "Atmosfera" 3. The "Neva," costing about 25 rubles, or 27 dollars. 4. The "Efir" 5. The inside and speaker of the "Efir." (Note the coin and "Vivo" cigarette pack for size comparison.)

4.



5.





Automobile Radio Receivers

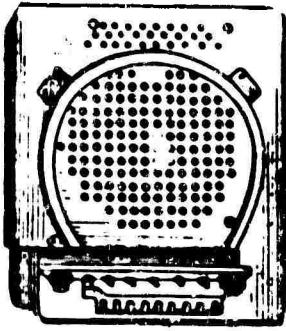

The "A-5" used in the Zil-110 and the Gaz-12

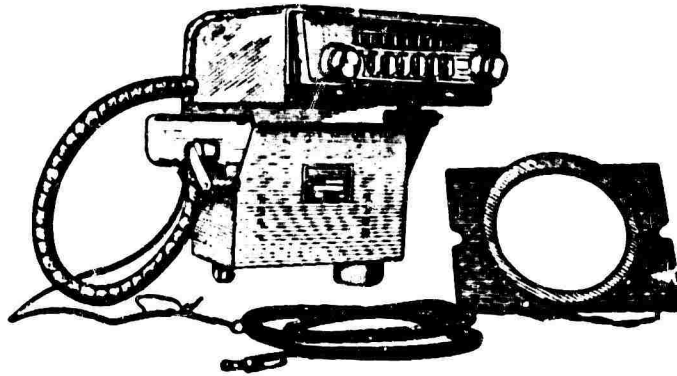

The "A-8" used in the Pobeda and the Moskvich

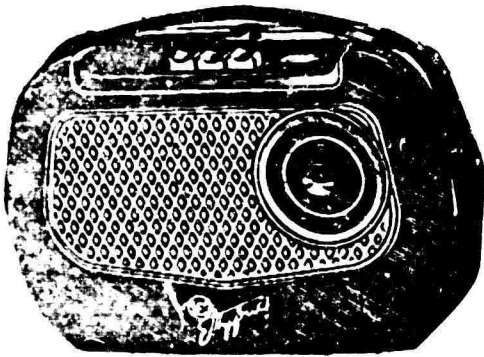

The portable "Turist"

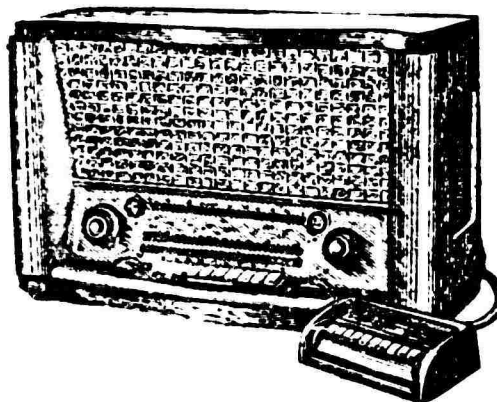

The "Festival" (Note remote control tuning apparatus)

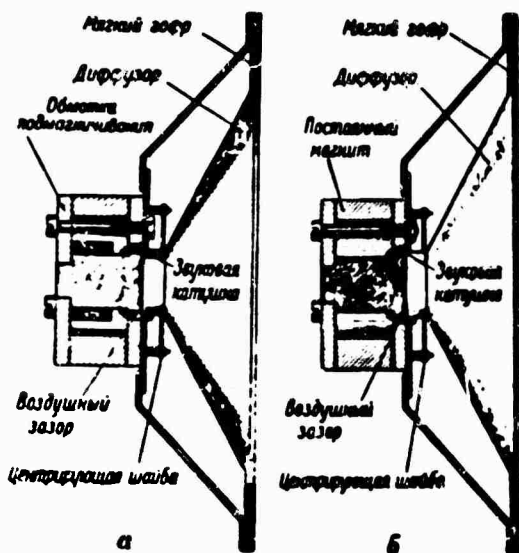

Two Electrodynamic Speakers, the principle types used for both wave and wired speakers in the USSR

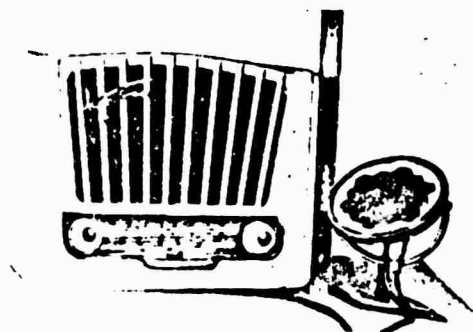

The "Kristal", a solar-powered radio set

set is available, however, mainly in stores which sell receivers for foreign currency, and is not at this time generally available for sale to the average Soviet citizen. Its Soviet price is about 40 r bles. A smaller set, also long and medium wave, about the size of a book of matches, was released in November of 1964, but has not yet reached mass production. At present, the ideal receiver for the Soviet radio consumer would be a small, portable, pocket-sized set with short wave, preferably below the 25 metre band.

Here a few words are in order about the way in which an average Soviet citizen evaluates and purchases a radio set. Unlike the average American radio consumer, the Soviet citizen generally has a rather good knowledge of the significance of certain technical data concerning the set to be purchased. Such information includes selectivity, sensitivity, output and input power, size and voltage of batteries, life span of batteries<sup>32</sup> and tubes, number and type of transistors, and so on. Most of this information is contained in a small pamphlet attached to the Soviet set which is for sale; this booklet is called the "passport" of the radio, and includes also the forms for registration and guaranteed repair registration. The weight of the portable radio, and whether or not the set is made of plastic, are also subjects of vital consideration. The Soviet preference for plastic in both portable and stationary sets, even in radio-phonographs, is a result of two trends of thought. The first, the practical consideration, is that plastic is the least expensive material adaptable to cabinet production in the Soviet

Union. The second is that plastic is still considered a thing of the future, an innovation, and as such, is considered modern and progressive, and therefore, fashionable. While connoisseurs of sound reproduction recognize the acoustical advantages of wood, and the obvious technical advantages of a component system, the person who is concerned with and cognizant of these factors is usually the engineer, and not the average buyer, or even the "enlightened consumer," as in America today. The most desired wave length band is the short wave band, since both many soviet stations, particularly those in Siberia and other sparsely populated areas, and foreign stations broadcast on this band for maximum reception. FM broadcasting is not highly developed, and so the FM band is a luxury on a Soviet set. Since FM stereo multiplexing is largely a thing of the future, if at all, and sound reproduction is poor, the demand for FM stereo sets is virtually non-existent among the broad strata of the population.

### Television Sets

Soviet television sets, like radios, have in the past been considered heavy and old-fashioned in design. In recent years, however, they have begun to appear in lighter, smaller models, with more attractive designs. They are designed for the 625-line, 25-frame standard, which is being used throughout most of Eastern Europe. (For comparison, a 525-line standard is used in the U.S.A., and a 405-line standard is used in England). Channel width is 8 mc. The later sets have 12 channels, the first five between 49 and 100 mc, and the other seven between 174 and 230 megacycles. Not all channels are in use, and many areas

use only one channel. Moscow uses three channels, as does Leningrad, and most large cities have two or are planning to initiate a second one in the near future. Semi-conductors are apparently widely used, and at least one all transistor set has been developed.

Newer Soviet sets include the "Soyuz," the "Start," and the "Rekord," all of which have 10 inch screens. The "Temp-3" has a screen of 12 inches, and the "Temp-4" has one of 14 inches. These sets also have built-in radio receivers capable of receiving FM broadcasts. Most of these sets are to be discontinued in the near future, as will be described later. The "Neva" and the "Yantar" both have 14 inch screens. The largest screen is that of the "Moskva" set; although it is only a small screen (6 cm in diagonal!), its image is projected by means of a special optical system onto a screen .9 by 1.2 metres. It can thus be seen by 200 viewers at a time. This type of set was designed for use at clubs and rest homes, and is particularly adapted to such use, since it may be tuned by remote control

Several interesting technical innovations in Soviet television have been publicized recently in the Soviet press. One of these is a film of aluminum several microns thick, which is applied to the inner surfaces of the picture tube; this lengthens the life of the tube, and provides a brighter picture with better contrast. Another innovation is a set with a rotating screen, which can be turned without turning the entire set. An experimental model of this set was manufactured in late 1962. Transistorized, portable television sets are also being produced.

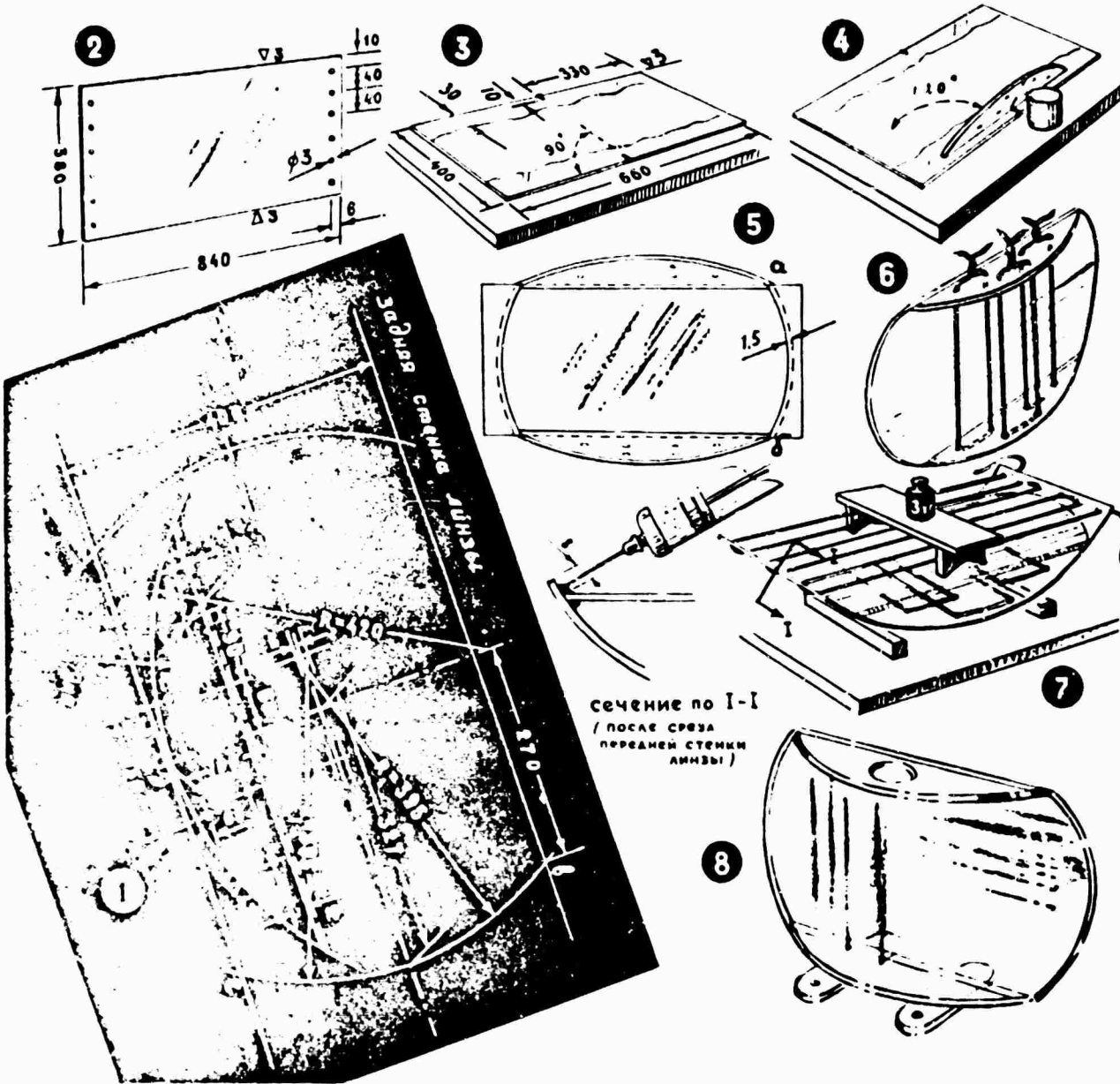

Caption reads: "Lens for a Wide Screen". Drawing shows construction procedure.



Portable television camera

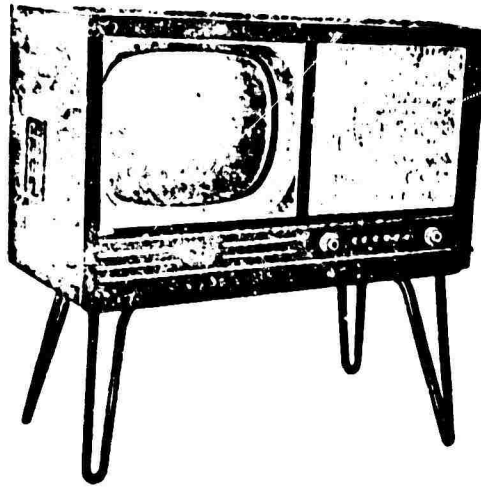

"Symphonia"

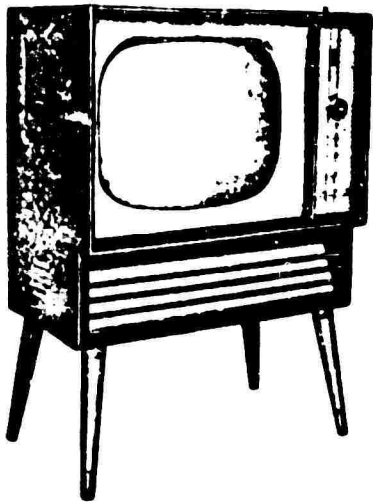

"Druzhba"

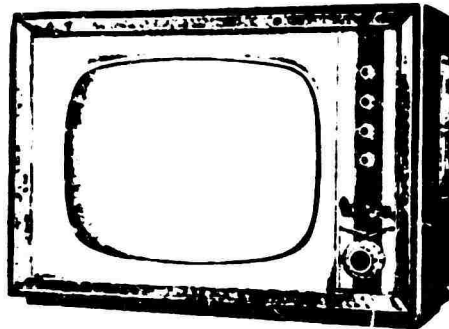

"Volna"

Some recent models of Soviet television sets.

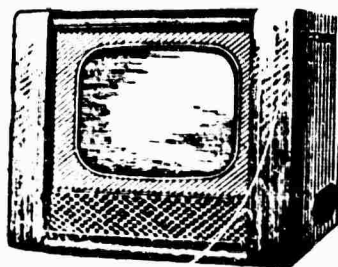

"Rekord"

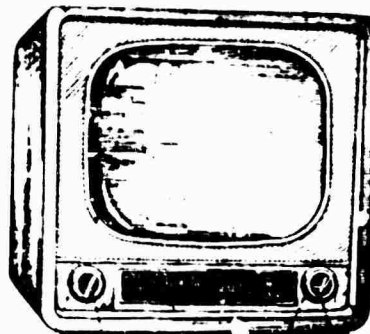

"Rubin" 1-brightness 2-volume  
3-contrast 4-timbre 5-tuning  
6- range

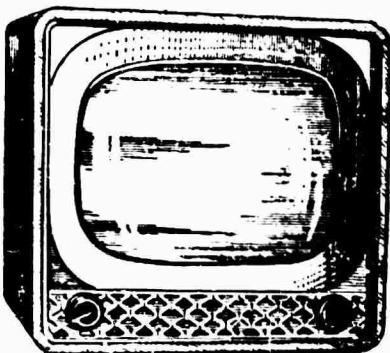
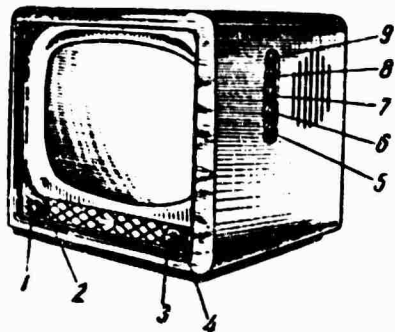

"Yantar"  
1-brightness 2-volume  
3-tuning 4-range 5-contrast  
6-timbre 7-timbre 8-frequency  
9-frequency

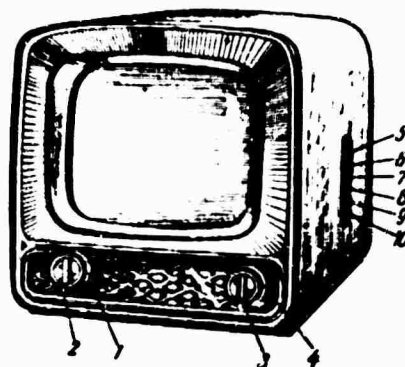

"Start" 1-volume 2-contrast  
3-range 4-tuning 5-timbre  
6-frequency 7-frequency  
8-vertical 9-brightness  
10-horizontal

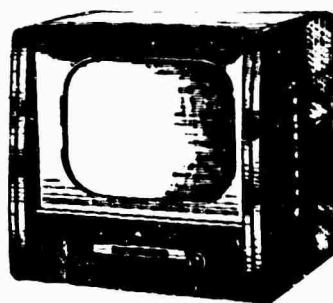

"Temp-3"



Development of wide screen television is also connected with an interesting invention. In the picture on the following pages, one can see the principle involved. The set owner is able to construct his own wide screen--a remarkable do-it-yourself improvement. Color filters which can be placed in front of the screen in a like manner have also been mentioned, but the Soviet Union also is developing its own system of color television. Other devices include an "instant translator," a device which can be attached to the television set on which a program is being broadcast in Russian. By means of this device, the listener can hear the program being broadcast in his own national tongue. Invented by the Leningrad Radio Reception and Acoustics Institute and engineers of the Estonian Television Center, the attachment was first tested in Estonia at the end of 1962. By choosing the proper channel, the listener may hear the broadcast in either of the two languages.<sup>33</sup> Indications are that the device is being used in several regions of the country.

#### Future Radio and Television Sets

Several sets were designed for production during 1964 and 1965 which supposedly will alleviate some of the difficulties previously present in set production. The factories producing television and radio sets have been instructed to cut down on the number of models produced. Television sets with screen sizes of 35, 47, and 59 cm (diagonal measurement) will be produced on a single construction of cabinet and printed functional block. A 47 cm screen set is being produced, which will use semi-

conductor instruments, and can be operated either by wire or by battery. The following sets will be produced in the various classes:

Class III- the UNT-35 will replace the models "Rekord-B," "Rekord-12," and "Yenisei-3" (all are table models).

Class II- the UNT-47 will replace the sets "Radiy," "Rubin-102," "Rubin-202," "Topaz," "Temp-6," "Verkhovina-A," "Belaruss-110," "Belaruss-5," and the "Neman" (all are table models).

The PPT-21 and the PPT-47, both transistor sets, will replace the table model "Start-3."

The new sets are reportedly to be much lighter in weight and smaller in size. Most of them will have picture tubes of 110°, although the portable one will have a picture tube of 90°. Metallic-glass picture tubes will replace glass picture tubes. The yearly output of television receivers for the next two years will be about three million in each year.

Radio sets produced will also be in limited numbers of models. The First Class Rigonda, a stereo-radiola, is replacing the models "Latvia," "Komet," and "Kama-62." The Second Class stereo-radiola RSKP-64 is replacing the "Muromets-62," the "Fakel," and the "Melodia." The Third Class radiola Siberia (the mono-phonic variant) replaces the models "Rekord-53," "Rekord-61," "Rekord-61M," and the "Promin." The radiola Fourth Class, the Serenada, replaces the "Strela," and the "Zarya." The table-portable transistor radio Kosmonaut replaces the radio "Nareck;" the portable transistor radio Selja

replaces the "Gauya;" the semi-conductor model Alpinist replaces the "Atmosfera-2." The pocket transistor radio Jupiter replaces the "Neva-2" and the "Lastochka-2" and the "Mir." Conventional radios and radiolas will be issued in yearly quantities of five to six million per year for the next two years, about half of them to be semi-conductor models.

The Rigonda-S, a First Class stereophonic radio-phonograph, is pictured on the next page. It consists of a radio-receiving set combined with a phonograph, which will play records of 78, 45, 33, and 16 r.p.m. The phonograph has an automatic stop device and a "micro-lift" playing arm. The radio set itself has two internal antennae, one tape dipole for FM, and one magnetic antenna for medium and long waves. It is, therefore, capable of receiving FM stereophonic broadcasts. The buyer has a choice of table model or floor model with legs, and of either horizontal or vertical speaker cabinets. Inside each of the two cabinets are two speakers. The table model weighs about 19 kilograms and the floor model, 21 kilograms. The cost is about 220 rubles. The Popov Radio Factory in Riga, and the Ordzhonikidze (West Ural Sovnarkhoz) Factory is producing the set, and expected to produce a total of 160,000 of these sets in 1964.<sup>34</sup>

Wired radio sets now being sold in urban stores are priced in range from about 4 rubles (\$4.50) to 8 rubles (\$8.90).

In June of 1964 there appeared in the newspaper Komsomolskaya Pravda, famous for its Public Opinion Institute, the announcement of a new contest/opinion poll relating to the design

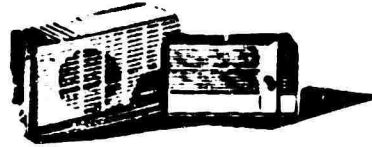
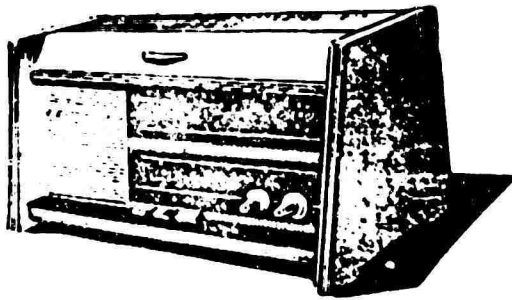
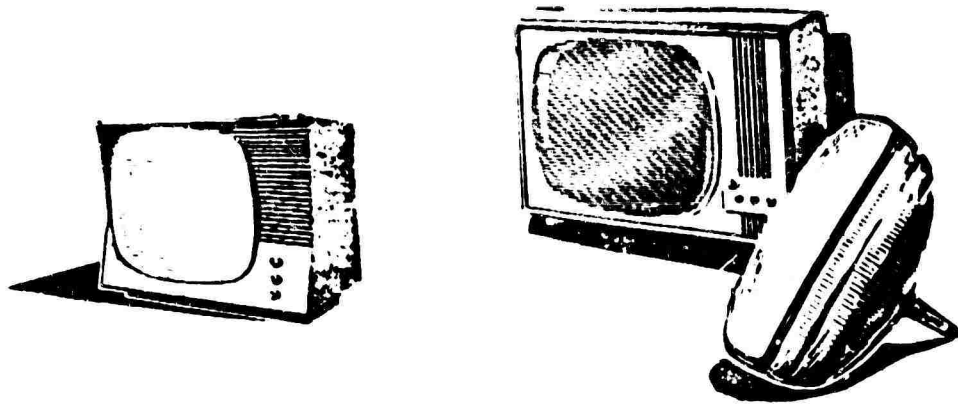

Several of the latest models of Soviet television, radiola, and radio sets.



The Rigonda-S, the latest First-class Soviet radio-gramophone. Above: Variant one, with vertical speaker cabinets and floor model receiving set. Side: interior of gramophone. Below: Variant two, with horizontal speaker cabinets and table model receiver.

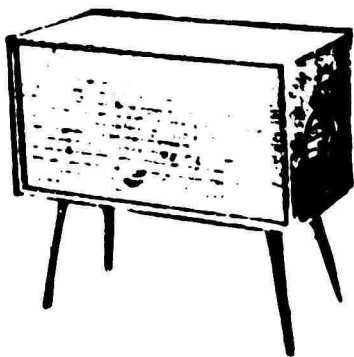

of radio, television, and sound reproduction equipment.<sup>35</sup> The article, entitled "Let's Design!" invited readers to criticize existing radio equipment and design the type of models they would like to see available. The following questions formed the questionnaire which was the basis for suggestions to be offered by readers:

1. What type of television set would you prefer? (table, floor, portable, rotating screen, size of screen, etc.).
2. Do you need a remote control device for TV sets and radios?
3. Is an automatic record changer necessary in a record player?
4. What kind of external finish would you prefer? (shellac, matte, natural, colored, red, light or dark wood, plastic, loud or subdued colored plastic).
5. What type of television, radio, record player, tape recorder, do you have?
6. What do you like about it and what don't you like; what changes should be made?

Before August 1, the deadline for the return of entries, the Institute received some 14,000 replies. The letters were processed over a four month period. Some of them were printed on September 12;<sup>36</sup> others, including the winning entries, presented with illustrations on October 28<sup>37</sup> on the back page of the issue, the customary location for the publication of the work of the Institute. Winners were given models of existing radios and television sets. Some winners received recommendations by the jury to enter design or technical institutes.

The contest revealed some interesting opinions. Most replies seemed to indicate that while such devices as remote

control and automatic record changers were desirable luxuries, they were not primary and that more practical concerns far outweighed any desires for such extras. The majority of persons replying were unhappy with the size and awkwardness of radio and TV sets, record players and tape recorders. They would prefer that they be portable, transistorized, and that TV screens be of the rotating type. They also objected to duplication of amplifiers and speakers. It was felt that a system of components, produced in varying qualities and prices, would be more practical in combination in an apartment, thus saving room and money in purchase. Tastes in design ran toward clean, modern lines, although the preference for shellacked woods or white or yellow plastic seems quite old-fashioned by American standards. Reasons given were that plastic is cheap, does not require much labor in finishing or upkeep, and is elegant, although wood is better acoustically. Winning entries suggested a "false stereo" system, separation of speakers from tuners and turntables. Answers as to the place of the equipment in the room differed: some felt that the equipment should be designed so that it was subordinate to the design of stationary pieces, and would not stand out. One military serviceman, however, felt that the electronic equipment in his apartment formed a "twentieth century corner" (much like the old icon corner in the traditional Russian household) and that these symbols of progress should be so placed as to emphasize their position of deserved respect.<sup>38</sup>

## Subscription Fees

Until almost three years ago, there was a system of fees, payable to the Ministry of Communications, for the use of the radio and television set. The fee constituted one of the sources of the budget of the Ministry, and was intended to pay for programming costs. The size of the fee varied according to the type of receiver, and to the place in which it was located. Thus, automobile radio receivers in the automobile "Pobeda" ("Victory") were subject to an annual subscription fee of 75 rubles (7.50 new rubles or about \$8.33); radio sets in apartments were subject to a subscription fee of 36 rubles (3.60 new rubles or about \$4.00). The fine for failure to pay the subscription fee was 50 rubles (5.00 new rubles, or \$5.55). The fee was to be paid within a twenty day period from the time of purchase. The failure to pay the subscription fee for a television set was twice as much, or ten new rubles.<sup>39</sup> Usually this fee was collected separately, sometimes at the time of purchase, but often, as in the case of Latvia, other means were employed. There the system of collecting subscription fees along with apartment rents was considered justified and worked well.<sup>40</sup>

In August 1961 it was announced that registration of all television and radio sets, as well as the collection of subscription fees was to cease as of January 1, 1962. The conditions of the decree stated that all those who had bought a television or radio set before January 1, 1959 would stop paying for the use of it as of January 1 regardless of whether it



was installed in an apartment, dormitory, or car. Those who had bought sets since January 1, 1959, would continue to pay subscription fee until after the expiration of the three-year period from the day of registration. However, for those who ceased to pay the subscription fee, there was to be a "certain additional fee" to be paid at the time of purchase, in order to cover expenses for the organization of radio and television broadcasts.<sup>41</sup> The amount of this new fee, according to various types of radio sets is not known.

#### Repair of Radio and Television Sets

While there have been many difficulties with the repair of all electrical appliances in the Soviet Union, the situation seems especially serious in regard to radio and television receivers. In most cases, the term of guaranteed repair extends until six months after the date of purchase. This guarantee, however, operates under certain limitations. To begin, in many localities there are inadequate facilities for guaranteed repair, which is often carried out in separate shops. Often there are no repair facilities at all within commuting distance of the set owner. There are no delivery services for repair facilities, with the exception of Moscow, Leningrad

and a few other large cities. The enterprises at which the repair is performed are paid eight rubles (about \$8.90) for each job; this sum is taken into account in the original purchase price, and paid by the manufacturer to the repair shop. It is, then, actually the customer who pays for the "guaranteed" repair. In Moscow in 1962 there were 19 shops of the Teletrest Enterprises, which does repair work, and an additional 14 receiving points.<sup>42</sup> For repair of radios, there were 21 repair shops and 24 receiving shops. In Leningrad there are only about eight repair shops. Given this scarcity, it is not surprising that an after hours private enterprises system of repair has grown up among those qualified to service sets. These qualified persons are, moreover, considerably fewer in number than the radio and television industries would care to admit. According to the Ministry of Communications, of the 1,289 mechanics of the Moscow repair ateliers, 575 have special technical education, including 490 graduates of technical schools, 82 graduates of technical high schools, and three university graduates. According to these figures, only 45 per cent of those working in the shops are qualified to perform repair services on receiving sets.<sup>43</sup>

The guaranteed repair period begins at the time of purchase. The owner formerly had to register his set and pay the subscription fee (now eliminated) at the Postal Communications enterprise, then register a second time for repair at the TV repair shop nearest to his house. He does this by

filling out the UTI (Accounting-Technical Card) which has its own number. The card has information on the set, the length of guarantee, the owner, and how to get to his house. When the set owner calls for repair, he gives the number of this card so that the mechanic can bring the card along with him and record information concerning the repair.

For non-guaranteed repair, the cost is calculated from three categories: (1) for a house call a fee of from \$.90 to \$4.00 is charged, depending on distance; (2) for various services there is a charge ranging from 11 cents for a replacement of a radio tube to \$7.50 for a tune-up; (3) cost of parts ranging from 80 cents to \$5.00. The time span for repair is officially up to three days for homes in area local to the shop, five days for those in general proximity, and ten days for distant locations.<sup>44</sup>

In addition to the red tape and the low quality of repair itself, one must also mention the high incidence of sets which must be serviced each year. During 1962 in Moscow, there were 1,116,000 applications for repair. This indicates a phenomenal rate of breakage, since the total number of sets in Moscow did not exceed 1,500,000. It is also indicative of the high value which the set owners attached to the sets, and to intolerance of being without a set for a long period of time.<sup>45</sup> Approximately one-fifth of new television sets break before they leave the store in which they are being sold, and a further 60 per

cent of them break within the six month guaranteed period.<sup>46</sup> Repairs have become so common a phenomenon that a special phrase, "pre-sale" repair, has crept into Soviet jargon. The reasons for this amazing rate of breakage seem to be numerous. First, there is poor quality control during production. Factory workers are frequently careless about assembly so that there occurs poor construction and alignment of front ends, coils wound with enameled wire from which the enamel chips off, poorly constructed controls, speaker voice coils which break away from the cone, fuses which fail to blow under overload resulting in burned-up power transformers, poorly constructed phono motors, and so on. An official study found that tube failure was responsible for about 31 per cent of television failures; picture tubes cause 4 per cent; selenium rectifiers cause 5 per cent; other defective components 9 per cent; and defects in manufacture and assembly 18 per cent.<sup>47</sup>

One of the reasons cited for the great number of television failures is the great number of different models of sets, preventing the technician from learning thoroughly how to repair the various new types which come to the market each year. In 1961 there were reported to be over 70 models, 23 of which had been newly designed that year. These models were produced by more than fifteen factories, all of which seemed to feel, "It may be bad, but it's ours," as the foreman of a Moscow television repair shop phrased it. In Khrushchev's November, 1962 speech to the Central Committee Plenum, he complained of this very lack of standardization:

The forces of designing of radio and television sets are scattered throughout the country in 17 different design offices. The manufacture of television sets is carried out at 19 different factories, and that of radios at 32 factories. These factories, situated in different cities, put out radio and television sets of the same class, but of different design and dimensions. There are 12 makes of television sets of the same class, and 47 makes of radios and radio-phonographs on the production lines this year. This is very often a kind of window dressing. Actually, many radio and television sets differ only in size and color: one will be called a "Belaruss," the other a "Kiev." This totally unjustified profusion of types hinders the organization of mass production of television and radio sets, holding back the application of highly productive, mechanized equipment, and blocks the reduction of production costs and the improvement of quality. It is not surprising that the production cost of the same type of set varies widely.

Other problems include distribution and lack of necessary parts. In Stalingrad, a complaint in the year 1960 was that a great number of "Rodina-52" sets were on the market. These sets, it was complained, were poorly designed, awkward, and expensive. On the other hand, the "Minsk-T" set, which was better and cheaper and in great demand, was scarce in that area. IZVESTIA in the same year reported that of some parts there was available only 50 per cent of the number needed; of others there was only 80 per cent. This shortage is partially due to the fact that as soon as a set ceases to be manufactured, production of its parts also ceases. This seems to have been the case with the "Rubin-102" set. One-fourth of this model needed repair before they left the stores in which they were being sold. Over one-half needed repair during the six month guarantee time. When the set was removed from production in 1961 its parts also ceased to be produced; for owners of the set who had been having repeated troubles with the set, this was the straw that broke the camel's back.

### III. The Administration of Soviet Radio and Television

#### Structural Apparatus of the Broadcasting Administration

Until 1957, broadcasting in the Soviet Union was under the jurisdiction of the Ministry of Culture; at that time, a resolution of the USSR Council of Ministers announced the formation of the organization which now holds primary responsibility for the administration of radio and television. This body, the State Committee on Radio and Television of the Council of Ministers, has corresponding bodies which act as its representative in the lower administrative levels, such as union republics, autonomous republics, oblasts and krais. These lower bodies are generally called either editorial boards of radio and television, or committees of radio and television. Under these editorial boards or committees, there are usually departments of lower broadcasting. Rather than actually preparing the broadcasts themselves, these departments contain main inspectors, senior reviewers and reviewers who check on the work of the local broadcasting committees under them. Their function is to act as control agents for the content of local broadcasting, such as in a diffusion exchange, and to "help eliminate errors."<sup>49</sup>

The State Committee for Radio and Television of the USSR Council of Ministers is headed by a chairman, now Nikolai N. Mesyatsev. Mesyatsev, a former Komsomol official, has had primarily a political background with a great deal of experience in organizational work.<sup>50</sup> As Chairman of this

committee, he outranks Gromyko on the Council of Ministers. He is aided by one deputy chairman, who is simultaneously the chief (nachalnik) of the Main Administration for Radio-broadcasting, or "Central Broadcasting." The Committee (more accurately called a Bureau in Western terms) includes: the Main Editorial Board for Radiobroadcasting; the Main Editorial Board for Television; the Technical administration, with its various subdivisions; the departments; a creative apparatus which prepares materials for programs; and a body which handles the technological problems of sound recording. Broadcasting plants themselves, including studios, television centers, amplifiers, and lines for broadcasting, are under the jurisdiction of the Ministry of Communications.

Central broadcasting is headed by a chief, as mentioned above. He unifies twelve main editorial boards, which are individually headed by editors-in-chief. These editorial boards perform the following functions, according to their specific designations:

Science and Technology--prepares programs on science and a radio-journal, called "Science and Technology" (Nauka i tekhnika").

Industrial Broadcasts--organizes materials on economics, the organization of labor and industry, illustrates the "progressive spirit of Socialist labor" by use of exemplary figures who have distinguished themselves as workers in industry.

Agricultural broadcasts--performs the above functions for

the agricultural sector, and publishes a radio-journal called "News of Agriculture."

International life--arranges programs on life in other countries; usually the programs deal with Asia, Africa, and socialist countries.

Youth--prepares programs on the Communist upbringing of young people; the Young Communist League (Komsomol) activities; and on youth in general.

Moscow--prepares programs which are primarily of interest to local inhabitants of urban and suburban Moscow; prepares "Moscow News."

Moscow Oblast--the same function for the larger oblast area, including preparation of "Moscow Oblast News."

Musical Broadcasting--this being one of the largest editorial boards, it is divided into the following sections: symphonic music; operatic music; chamber music; musical-educational broadcasts; "mass genres," music of the peoples of the USSR, of foreign countries, and of national (meaning Russian) music.

Children and young--divided into: school life; literary broadcasts for older children; literary broadcasts for younger children, scientific broadcasts for children; musical broadcasts for children; and broadcasts for parents. It also publishes the magazine "Pioneer Dawn."

Besides the main editorial boards, Central Broadcasting also contains the following departments: Letters; Scientific-methodological work; Control of Broadcasts; Publications;



Correspondent network; Information; Phono-grams (records); the Musical and Literary Libraries; and the announcers' group.

The department of the correspondent network essentially guides the work of the correspondents located at different points around the country. There are major offices, called "correspondent points," in centers of administrative regions; in 1961, there were thirteen of these, some of which were located in Leningrad, Kiev, Baku, Tbilisi, Sverdlovsk, and Ryazan. There were also in 1961, some forty-four other major correspondents stationed at different places around the country.<sup>51</sup>

The structure of an urban committee on radio and television can be seen from the following diagrams. Diagram II.A. is the exemplary committee of Leningrad. Since the Moscow television studio differs a good deal from the urban television studio which the Leningrad one typifies, a diagram of the Moscow studio structure has been included as well.

#### Functions of the Administration

Since radio and television programs on all levels depend a great deal, in terms of thematics and content, on the central administration, its functioning on these various levels is necessarily closely coordinated. Editorial boards and committees on radio and television make up their thematic plans for radio for a month in advance, in order to ensure the compatibility of themes chosen with currents in programming

The Structural Apparatus of the Administration of Soviet Radio and Television Broadcasting

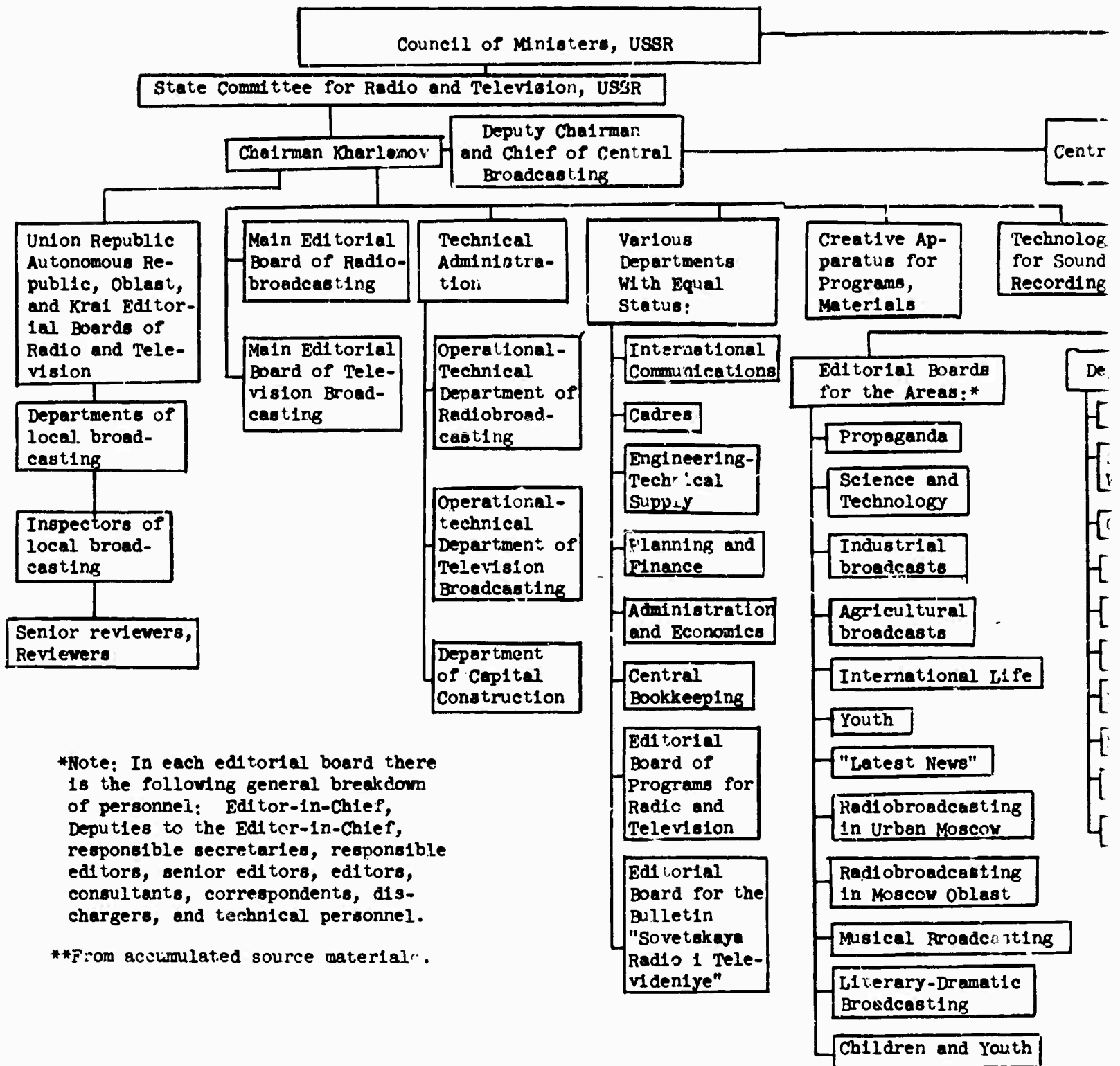

\*Note: In each editorial board there is the following general breakdown of personnel: Editor-in-Chief, Deputies to the Editor-in-Chief, responsible secretaries, responsible editors, senior editors, editors, consultants, correspondents, dispatchers, and technical personnel.

\*\*From accumulated source materials.

A

Administration of Soviet Radio and Television Broadcasting \*\*

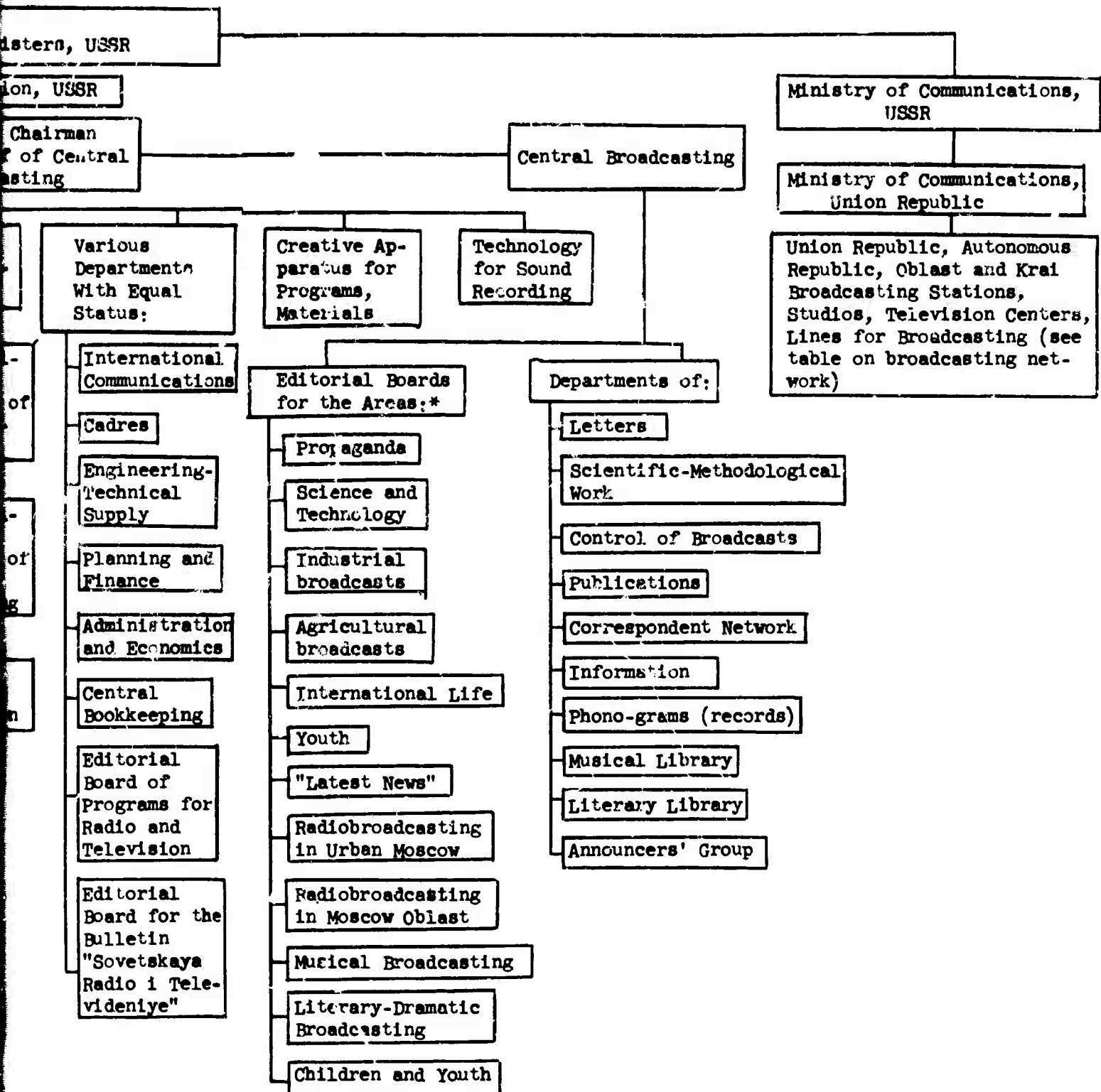

policy. Editorial boards of youth and of literary-dramatic subjects sometimes plan their schedules three, or even six, months in advance. From the main points included in the long-range plans, the editorial board makes up more detailed weekly plans, indicating the length of broadcasts, authors, and so on. These plans are then passed on to the editorial board of programs of the State Committee, where they are unified. These "Radio-programmy" are then printed and distributed by Soyuzpechat, the newspaper distribution agency. This is done once a week, usually on Saturdays.

Local committees carry out their own daily broadcast schedule, taking into account the program of Central Broadcasting. They choose the time when their programs will least conflict with the important programs from Central. If Central begins to broadcast some important event or announcement, the local committee may have to interrupt its program, or record the announcement to be broadcast later. In rural regions and separate factories, local broadcasts are also organized to be broadcast over the diffusion exchange. The broadcast is carried out by two or three collaborators, for about thirty minutes at a time, about three times a week. The inspector of local broadcasting controls the broadcasts over the diffusion exchange.

Unlike radio, television relies a great deal on local materials for broadcasts, which are supplemented from the Moscow central program. In the department of local broadcasting in Moscow, there is a group which collects film

materials from Central Television; the materials are then sent to the local networks to be broadcast. This situation particularly applies to an event such as the Party Congress, when films taken at the Congress are issued in special "film journals" to be broadcast over local television stations throughout the Soviet Union.

Party control over the administration of radio and television takes the usual forms which it takes in other areas of Soviet life. The most evident means is the Party directive, which evaluates and criticizes activity of the broadcasting administration, and outlines measures for improvement. Less noticeable to an outsider, but hardly any more subtle, is the placing of Party members in high positions in the administration. Third, the Party also manages to maintain a certain number of its members in the lower levels of the apparatus, so that coordination is maintained within the Party control. The main bodies as well as local bodies of the administration are under the supervision of regional and local Party committees, and, particularly, of Party and State Control agencies, which maintain Party discipline.

#### IV. Programs and Hours of Broadcasting

##### Radio<sup>52</sup>

In volume of broadcasting time, Central Broadcasting in Moscow holds first place in the country. As core of the broadcasting system, it prepares broadcasts which form the basis, if not the overwhelming bulk, of broadcasting schedules in localities. The proportion of Central to local broadcasting in a local broadcasting schedule varies, but in general is greater in the European part of the USSR. Times of local broadcasting are given in Table III.C.;\* although this table was compiled from information gathered before the change in programming in October, 1962, it may help to gain some idea of the varying proportions of local broadcasting throughout the republics. Central Broadcasting generally organizes its broadcasts in consideration of the time differences throughout the country. For example, in the Far East, Moscow's evening programs would not normally be received, since they fall there during late night hours. To account for this, special broadcasts are made for the Far East, and in the revised programming schedule the Fourth Program, which broadcasts to this region, operates around the clock, having increased its broadcast time per week from 35 hours to 168 hours, or by 133 hours per week. The control

---

\* See Appendix III, Table C

figures for the recent Seven-Year Plan, to end in 1965, planned 81 hours of broadcasting for Central Radio (in 24 hours), and 778 for the entire country.

The above mentioned change in programming was first announced in a decree of the Central Committee of June 6, 1962; it was not published openly until it appeared in the latest edition of the Party Workers' Handbook (Spravochnik Parti-inovo Rabotnika, fourth edition, 1963). In addition to outlining some of the achievements and shortcomings of Soviet radio, it included a significant increase in the amount of broadcast time of the four Moscow radio programs. Probably the primary reason which caused the Soviet government to increase its broadcast time, at the same time providing more topical information and foreign news, was competition with non-Soviet stations. The growth of wave sets in the Soviet Union has already been underlined. With the adaption of the wired set to a system of multi-programming, the natural means of competition with the Western wave stations is to improve domestic broadcasting. This has the aim of luring Soviets with wave sets away from the non-Soviet stations, as well as increasing the satisfaction of those who do not own wave sets by giving them a choice of several interesting domestic stations. The admission that this was the prime motivation for the changes is included in the decree:

In the interests of improving the country's radio broadcasting and of active counteraction against hostile radio propaganda, the State Committee of the USSR Council of Ministers for Radiobroadcasting and Television, the Central

Committees of the Communist Parties of the Union Republics, the Kraikoms and Obkoms of the CPSU are obliged to assure strict coordination and dovetailing in the work of the central, republican, krai, and oblast broadcasting, so as to improve the ubiquitous reception of radio broadcasts from Moscow.

Thus, better programming is to replace jamming of Western broadcasts as the major means of combatting "hostile radio propaganda."



## Television

As we have mentioned before, the programming of local television is not so dependent in content and thematics on the central television broadcasting apparatus as is the case with radiobroadcasting. The Central Television Studio is, however, the core of the Soviet television network, both administratively and technically, and, as such, is the most important example of programming procedure. The average daily volume of television broadcasting, as published by the Committee on Radio and Television, is as follows:

	1955	1959	1965 (plan)
Total USSR	15.4 hours	158 hours	510 hours
Central TV Studio	4.4 hours	8 hours	25 hours

The decreasing proportion of Central Studio's broadcasting time is evidence of the rapid growth of the television network as stations were built throughout the country as a whole. The 25 hours planned for 1965 as a daily volume of broadcasting is yet a matter for consideration, but a goal that may well be reached, especially with the addition of a third program of broadcasting in Moscow in the fall of 1963. According to a study by Richard Tuber, published in the Fall, 1960 issue of Journal of Broadcasting ("A Study of Programming on the Central Studios of Television, Moscow, USSR, January-June, 1960"),<sup>54</sup> the average broadcast time per week for the First Program was 34 hours, and that for the Second, 19 hours, totalling 53 hours per week. With an increase in broadcasting time offered by the new Third Program,

plus the planned National Television Center in Moscow, an expansion to 25 hours per day does not seem an unrealistic goal by any means. In 1960, the First Program reportedly broadcast for an hour during the middle of the day (usually 11 a.m.-12 noon), and from about 6 p.m. to 11 p.m. The Second Program, intended primarily for the Moscow area and its immediate environs, began its broadcasting anywhere from five hours prior to, or two hours after, the beginning of the daily schedule of the First Program; broadcasting ended for the Second Program at 11 p.m., as it did for the First Program. A report of May, 1963, indicated that the broadcasting schedule at that time had not changed significantly from the 1960 schedule described in the 1960 article. A daily hour-long show was shown at noon, and programming took place from about five to eleven p.m. each evening. Sundays' program ran from noon to midnight without interruption. It is expected that the Third Program, however, will significantly change this programming schedule, although no systematic report has been made at this time.

We have little information on the programming schedules of local broadcasting stations. An examination of Table I.G. ("Television Studios in Operation in the USSR") will give us, however, some idea of the number of channels, days per week on the air, total amount of time on the air, and the amount of studio and on-the-spot broadcasts. This information, however, has been somewhat outdated by the rapid growth of the television network, and the expansion of broadcasting

hours by studios already in operation.

As for the content of broadcasts and proportion of various topics on which programs are broadcast Table III.E. should give us some idea. Again, it should be pointed out that this table was constructed three years ago, and is probably somewhat outdated at present. It is not expected, however, that the time devoted to certain topics has been drastically altered by the addition of more programs or stations on the network. This table, then, is probably more representative of the present proportions than of actual broadcast time on the air.

#### Educational Television in the USSR

Mikhail Kharlamov, the former Chairman of the State Committee on Radio and Television, USSR, made the following remarks on the future of educational television in the Soviet Union:

We recognize clearly the enormous potential of radio and television for education. We are beginning to use both of these media for teaching science and medicine. Soon we shall have the finest lecturers, and newest scientific experiments will be discussed and described over the air. These incomparable media must not be just a waste of time. They must be intellectually stimulating, vital, full of ideas. We are planning to launch special education courses for the broadest possible audiences. We shall utilize these media to educate our people, to raise their esthetic tastes, and to help make them more fully developed human beings.<sup>55</sup>

The apparently insatiable thirst of the Soviet people for education has been noted by many persons studying and traveling in the Soviet Union. This fervor has grown remarkably

in the last few years, as has American feeling for education, since the launching of Sputnik I.

Since the building of the new television center in Moscow, and the subsequent attempts at re-vitalizing the television network, the desire to develop the field of educational television has reflected this striving toward higher learning. Former Chairman Kharlamov is quoted as having said that one channel would be set aside for the visual support of correspondence courses. These courses, unlike their American equivalents, usually carry formal credit toward a specific degree at an institution of education. Kharlamov considers this form of education, via television, as one of the perfect methods of solving the problem of educating the adult in higher skills and learning. "These courses," he says, "offer an incomparable opportunity. We are going to develop them energetically with radio and television."<sup>56</sup> Certainly the professed Soviet purpose of using television and radio for fulfilling the "needs" of the population is conducive to the large-scale development of educational television as is the ever-increasing emphasis on education in general in the Soviet society.

Quite a few specific courses have been developed for television to date. Most of the early lessons have included English or some home, factory, or agricultural skill. Recently some 52,000 farmers in regions surrounding Moscow were members of a television correspondence course in scientific agronomy. Students were divided into small, manageable groups

and attendance was taken by a special monitoring system. Probably this course was one consequence of the pet Khrushchevian preoccupation with agriculture.

The first exclusively educational television program (channel) in the Soviet Union was instituted on September 8, 1964. Broadcasts are three times a week, including Tuesdays and Fridays, the total number of hours per week being 10 hours, with an average of more than three hours daily. Three types of educational programs are broadcast. The first is in connection with the North-West Technical Correspondence Institute. Subjects taught include higher mathematics, general chemistry, and physics, and other subjects taught at the VUZ (higher Educational Institute) level. For this type of broadcast, sets are located in large institutes and factories so that workers in these places can improve their knowledge by this system. No diplomas are being awarded the first year, which is yet in progress, but may be in the future, when correspondence education will be closely combined with televised courses as it is in the United States.

The second type of program includes visual lectures for students in VUZes. Sets will be located in classrooms of these institutions. The third type is supplementary adult education, and "brush-up" courses. All teachers on the channel are to be professors and Doctors of Technical Science. Equipment for laboratory experiments is located either in the lab or in the studio, depending on the course. There is an individual studio at the television center for this channel.

The most used television set for educational TV is the SIGNAL, which can be seen by about 20 persons. For larger audiences, a projection type set, such as the MOSKVA is used.<sup>57</sup>

#### Radio and Television in Dnepropetrovsk, Ukrainian SSR

The present paper does not purport to make an exhaustive analysis of the content of programs on radio and television. In order to gain some idea, therefore, of a typical region and the kind of programming it enjoys, we might take the example of Dnepropetrovsk in the Ukrainian SSR, as a non-urban area situated in a location fairly distant from Moscow. Since we already have a typical collective farm near Dnepropetrovsk (see page 18) we can see from our program sample what sort of programs the collective farmers are likely to have available for their entertainment and edification.

The Dnepropetrovsk television station has been broadcasting six times a week since 1958. Most programs are broadcast in the evenings, and include a great many programs which are industrial or agricultural in content; exemplary programs might be: "Through Heroic Labor We Shall Execute the Grandiose Communist Assignment," "Fulfill the Seven-Year Plan Ahead of Schedule," "Lectures for Corn Growers," "The Television University of Culture," "Folk Creativity," "Soviet Woman." Once a month the studio presents a television newsreel called "News of Dnepropetrovsk Area." Twice a week the studio, in collaboration with the Bureau of Technical Information of the Sovnarkhoz, produces a program entitled "For Technical

Progress." On Tuesdays and Thursdays, daytime programs can be seen.<sup>58</sup> These days are probably chosen as representing the major free days from work; in the Soviet Union, especially in provincial and farming areas, free days do not necessarily fall on weekends.

Radio programs in the Ukraine are broadcast in Ukrainian and Russian. The Dnepropetrovsk station broadcasts for the most part the republican radio programs, of which there are two, and adds about three hours of local broadcasting per day. Radio programs, too, are heavily saturated with broadcasts which inspire workers on to greater feats of labor, or otherwise are intended to instill Communist values in the citizens of the region. The instructive function of Soviet television is reflected in such programs as: "Remember These Figures, Comrades," "The Hundredth Day of the Seven-Year Plan" (occupying an entire broadcast day!), and a special series called "Evenings of the Ukrainian Radio." These evenings are designed to draw together workers of the same profession for discussion; after the last Party Congress, twenty-five such programs were held, including evenings for chemists, corn growers, transportation workers, and so on. Two regular programs, entitled "The Tribune of the Innovators of the Seven-Year Plan," and "People of Creative Labor," glorify persons who have been outstanding in their fields. On these programs, the "progressive leaders" themselves speak, and often sketches of their lives and work are given. In cooperation with the Ministry of Higher Education of the Ukraine,

a series of programs was instituted for the study of the history of the CPSU, political economics, dialectical and historical materialism, and subjects which are intended to be basic knowledge for the Soviet citizen. Children's programs include round-table discussions on education, and features such as "With Our Own Hands," a program telling children how they can help the grown-ups to fulfill the Seven-Year Plan. Even literary, dramatic, and musical programs reflect the educative and propagandistic, as opposed to entertainment, orientation of Soviet broadcasting. A program entitled "Labor is Glorious on Kolkhoz Soil" turns out to be a program of music consisting of works from the composers of the fifteen Soviet republics. Other titles of musical programs include: "Homeland, Party, and Lenin--in the Creativity of Ukrainian Composers," and "Musical Evenings for Brigades of Communist Labor." Many programs also are planned on the basis of letters received from listeners. On March 22, 1959, an entire broadcast day was devoted to letters from radio listeners, in which every phase of the normal program schedule was arranged in terms of listeners' letters, including the "Latest News."

#### Recording of Broadcasts

Since the beginning of radio, sound recordings have constituted a large part of the broadcasting schedule. These recordings are usually made by the technical department or sector of the editorial board of committee on radio and television. The basic method now used, which was instituted in



1945 (although improvements have been made in the system), is the electro-magnetic tape. All main editorial boards and committees on radio and television have repositories, called "phonoteki," in which old gramophone records and tapes are stored. It was estimated that 70 per cent of all programs broadcast in 1960 were broadcast from pre-recorded tapes.<sup>59</sup>

The State House of Radiobroadcasting and Sound Recording (Gosudarstvenniy Dom Radioveshchania i Zvukopisi) was instituted in 1950 for the purpose of providing Soviet radio with the technical supplies for tape recording of broadcasts, and to make for it archive and operational recordings. It also makes tape recordings of Central Broadcasting's programs to be sent to local radio stations. As of 1960, the GDRZ had four music recording studios, three studios for making literary-dramatic recordings, ten speech studios, and eight broadcasting studios. It also had three concert and fifteen mobile recording units. The library of the GDRZ has a library of recordings of over 65,000 works, constituting over 9,000 hours of broadcasting.

The All-Union Scientific Research Sound Recording Institute, which is under the jurisdiction of the State Committee for Radio and Television, is another sector of the sound recording apparatus of Soviet radio. Its purpose seems to be the development of up-to-date equipment for recording and broadcasting. Its purpose, as stated by the former head of the Committee, is as follows:

...a comprehensive solution of technical problems pertaining to all types of sound recording and sound reproducing equipment, as well as the elaboration of theoretical problems associated with the further development of sound recording and its application in radio and television.<sup>60</sup>

On the staff of the Institute is a small group of specialists doing research on electrical musical instruments. Work is also being done on video recording tape.

It has been repeatedly suggested that all television broadcasts as well as radiobroadcasts be pre-recorded, in order to ensure records of all broadcasts and higher quality of performance. The first Soviet models of video tape equipment were field tested at Central Television from 1961 to July, 1963.<sup>61</sup> In order to house equipment, and provide a center for work with video tape, a video recording room was constructed at Moscow Television Center. In the 30-foot square room, two units are installed, staffed by a supervisor, two video tape technicians, and two operators.

The video tape process in Soviet television has thus far been used mostly for rehearsal, for reporting space flights, and for transmitting important political events. Video tape equipment was used to record the speeches of Khrushchev at the World Disarmament Congress on January 16, 1963, at the Conference of the United Socialist Party of Germany, and on various other occasions. During the period November, 1962-March, 1963, some 100 hours of recorded programs were produced on video tape, of which only about 20 hours were broadcast. The time delay from between the recording and broadcasting is usually about eight hours. It seems clear that

the prime importance of videoc tape is considered that it can be quickly processed, monitored, and broadcast.

The use of video tape recorders reduces the preparation of the programmes according to plan. It may be expected that in future the process of the preparation of programmes in television will be analogous to that currently applied in sound broadcasting.<sup>52</sup>

It is not expected, of course, that video tape will replace film recording, since video tape is not suitable for long-term preservation, thus not desirable for operas and other events which are to be preserved.

Although the technical level of Soviet video tape machines is rapidly approaching that of American counterpart, it has the shortcoming of not being able to play tapes recorded on another machine. Thus, recording must be produced and played back on one machine.

## V. Intervision

The International Organization of Radiobroadcasting and Television was organized at Brussels in 1946. Among its founding members were the "People's Democracies," the USSR, fourteen West European nations. In 1949, the radio-broadcasting organizations of the West European countries withdrew, creating their own organization, the European Union of Broadcasting, and leaving OIRT as the main coordinating body for Soviet and other communist broadcasting. The center for OIRT is in Prague, where the technical center for the organization is situated. OIRT constituted the sponsoring organization for the creation of "Intervedeniye" or Intervision, which is the central network, connecting the television broadcasting systems of the major socialist countries. Intervision first included Poland, Czechoslovakia, and Hungary. In mid 1961 it was joined by the Soviet Union, and in 1963, by Rumania and Bulgaria.

In the permanent framework of Intervision are the Intervision Programme Coordination Center, and the Intervision Technical Coordination Center, both of which are located in Prague, the technical center for OIRT. The regular planning of the international program exchanges running in the frame of Intervision began in the year 1960. Only the program coordination was planned at that time; after the working out of the Intervision regulations, in which the system of technical planning was fixed, systematic work on technical planning and the actual management of Intervision transmission

began from September 1, 1960. The main provisions for the planning and preparation of program exchange and for transmission of broadcasts are included in the document "Intervision Regulations," the content of which was summarized in an article of OIRT's journal Radio and Television, (Prague) in 1960.<sup>63</sup> The technical planning and coordination of Intervision programs is effected by the Intervision Technical Coordination Center (TKCI). An international four-wire system serves to connect the TKCI with organizations participating in transmissions. A summary of the technical history of Intervision may be found in the OIRT journal Radio and Television, No. 2, 1963.<sup>64</sup> The growth of the Intervision network can be seen from the following two maps from that article. Note that Bulgaria and Rumania, who have recently joined the Intervision network, are not yet included on the map.

The Intervision network links the 224 television stations in the East European socialist countries (Yugoslavia and Albania excepted, of course) and the Soviet Union. According to an article by T. Kureka in Polytika (Warsaw weekly), of March 23, 1963, there were then approximately 100 million viewers. The number of sets and stations was as follows:<sup>65</sup>

<u>Country</u>	<u>Number of Stations</u>	<u>Number of Sets</u>
USSR	173	7,000,000
Poland	16	1,000,000
GDR	10	2,000,000
Czechoslovakia	11	1,300,000
Hungary	8	143,000
Rumania	5	68,000
Bulgaria	1	8,900

The USSR is the only country with two programs on the network, one transmitted from the Central Studio in Moscow, and one in part from the republic studios. For the most part, the East European nations have only one centralized program. The cable linking stations of Intervision runs through Kiev, Moscow, Leningrad, Tallin, Kaliningrad, Gdansk, Warsaw, Katowice, Berlin, Prague, Bratislava, Budapest, Bucharest, and Sofia. New lines linking Kiev and Warsaw, and Warsaw and Berlin, have recently been completed.

The above-mentioned article in Polytika notes that cooperation and program exchanges are still at a relatively low level. Because of poor organization of information and correspondence, there has recently been a cutback in the exchange program. To overcome this, special agencies were set up; 500-600 exchanges were planned for this year, of which the Polish network will broadcast about 36. In the course of Intervision's first three years of operation, a total of 1445 broadcasts were transmitted, totalling 1922 hours. Most broadcasts are either political in content, or

consist of sports events or concerts. The first broadcast was a four hour program from Moscow on Yuri Gagarin. Two weeks later, on May Day, 1961, the military parade and demonstration in Red Square was televised. From that time until December, 1962, the Soviet Union arranged 137 broadcasts abroad, and received 63 foreign ones. Soviet broadcasts have included the opening and diary of the 22nd Congress of the CPSU, a telecast from the editorial office of PRAVDA on its 50th anniversary, and celebrations of Soviet victories in outer space. Other broadcasts have included such subjects as the Prague World Championships in gymnastics, the Peace Cycle Race from the German Democratic Republic through Czechoslovakia and Poland to the USSR, the figure skating championship in Prague, and the football matches in Budapest and Stockholm.<sup>66</sup>



Source: " Experience in the Technical Operation of the Intervention Network", Radio and Television, (OIRT, Prague) #2, 1963, p. 26.





## VI. The Soviet Audience

### Size of the Audience

#### Radio

The actual size of the Soviet radio audience is difficult to estimate. The Chairman of the State Committee on Radio and Television, USSR, mentioned the figure of 150,000,000 out of a total Soviet population of about 224 million in 1963. Given the high incidence of collective listening in the Soviet Union, a tradition which has long had both political and economic foundation, it is difficult to know whether or not this is an accurate estimate of the number of persons who have access to a radio receiver. On the basis of the 1959 census projections, we have made estimates of the number of persons per wired set in 1961 (the last year for which we have complete figures for all the 15 republics) and per wave set in 1962. These estimates, of course, are nothing more than the proportion of existing sets to the population, and show us little about the actual access which people have to the sets.

#### Television

Various estimates of the television audience have also been made. According to various figures mentioned at different times by former Chairman of the Committee on Radio and Television, Kharlamov, the audience in 1959 numbered about 1,500,000; by 1963, the number had jumped to 35-40 million. In 1965 it is estimated that there are 12,000,000 television

sets and about 50,000,000 persons watching them.<sup>67</sup> As we have pointed out earlier, however, the distribution of this audience is very uneven, both in regard to European-Asiatic regions, and to rural-urban populations. Since we do not have constant figures for television sets in all of the republics, we cannot estimate the number of persons per set. Given the number of television sets for large audiences in rest homes and auditoriums, these figures would be difficult to estimate, even if we did have the proper corresponding figures for sets and population.

#### Nature of the Audience

With the rapid radiofication of rural areas in the Soviet Union, and the increase in the proportionate number of wave sets, the economic necessity for collective listening is slowly being eliminated. The suggestion is not that collective listening is a vanishing phenomenon. It has long been recognized as an effective political instrument of the Soviet regime in combination with group agitation, and its existence in this context is fairly well assured for a long time to come. Due to the elimination of collective listening for economic reasons, however, its practice has declined, and will, no doubt, continue to decline in the future.

As far as wired sets are concerned, collective listening is becoming unnecessary from an economic point of view. The trend in farming in recent years has been toward amalgamation and enlargement of collective farms, making use of

radio-loudspeakers for intra-farm communication almost a necessity. Most households on such farms, therefore, will in all probability have radio-loudspeakers. Whatever collective listening remains will probably take place around the wave set. This, of course, has obvious political implications, for it is by means of these wave sets that many individuals listen to non-Soviet, Western broadcasts. Needless to say, collective listening is not the ideal setting for such activity. We have, then, on the one hand, the necessity for collective listening on the wave set, and, on the other, the tendency to avoid it for political reasons, when listening to foreign broadcasts. Given these trends, we may summarize the state of collective listening as assured of an existence for the time being, but no longer as a feature of unique and central importance in the Soviet broadcasting system.

Prices of radio and television sets have reportedly declined in the past few years. The indications are, however, that price itself has not been a significant factor (at least within the last 20 years) in limiting the access of the population to these media.\* Inhibitions are rather those of distribution of sets and parts, to say nothing of problems with equipping broadcasting stations and radio diffusion exchanges.

---

\*The price of a 14 x 10 inch set in 1960 was 250 rubles, or about \$275.

Since Soviet broadcasting media are designed primarily to serve the "needs" of the population in terms of political information and cultural education, one should expect to find some contradictions between the desires of the population and the programming policies of the regime. We have already noted that many of the programs broadcast, especially in rural/industrial regions distant from Moscow, are directed toward increasing the political consciousness of the populace and mobilizing popular support for the fulfillment of plans. Frequently this programming meets with disapproval on the part of non-industrial, non-agricultural segments of the population. While an increasing number of programs appear to be provided for these other strata, it is doubtful whether the needs of the "masses" will ever cease to be the prime consideration in Soviet broadcasting, any more than popular culture in America will cease to be the overwhelming dictate of commercial television.

#### Audience Feedback and Listening Behavior

Our knowledge of the communications behaviour of the Soviet audience comes from two main sources--discussions of direct methods of feedback to the broadcasting system itself, and free time budget studies currently being carried out by Soviet social scientists. Direct methods of audience feedback include: (1) letters from listeners to the broadcasting systems or organs thereof; (2) conferences of radio listeners with radio broadcasting personnel; (3) visits to

homes or collective points by radio and television personnel; (4) telephone calls to radio stations and television studios by members of the audience; (5) questionnaires; (6) some program pre-testing.

The first method of feedback, letters from the audience, is the prime source of knowledge of reaction to broadcasting policy. This may be true both because it takes the least solicitive effort on the part of the broadcasting apparatus, and because it is somewhat informal, and in keeping with the established modes of the Soviet institution of "criticism and self-criticism." It is equated with the letter to the editor, or to the local Party or government body. These letters may be made to order, or simply selected for favorable or unfavorable comment, depending upon the campaign for any given time. The average daily mail of the Moscow television studio has been estimated at about 10,000 letters per day.<sup>68</sup> The All-Union Radio's mail has been estimated for the following years:

1949--246,210 letters	1954--303,000 letters
1950--202,796	1955--390,700
1951--194,063	1956--339,762
1952--222,057	1957--350,973
1953--256,625	1958--403,000

The greatest number of letters is reported to have been received by the editorial offices in charge of musical broadcasting and of programs for children and young persons.<sup>69</sup> Many programs are based on the letters received from listeners,

Such as "We Get Letters," "Replies to Letters Over the Air," and "A Survey of Letters from Listeners." Often the letters received are read and answered over the air. One instance is recorded:

The editorial office of the "Latest News" also frequently airs interesting letters and reports it receives from listeners. After the editorial office addressed itself to listeners with a request to write their friends... it received over two thousand letters. Every day for four months those interesting and disturbing letters were read over the air.<sup>70</sup>

It should be emphasized that most of the letters which are solicited from listeners do not deal with listeners' attitudes toward the programming. They may be requests for the solution of personal problems, complaints about local facilities, or some other topic. One example of such a letter is:

...a radio listener wrote in, saying that there is neither electric power nor radios in the Novo-Islambul village. His letter was referred to the secretary of the Krivosheinsky Rayon Committee CPSU of the Tomskaya Oblast. Some time later a reply was received. Secretary of the rayon committee reported that the Novo-Isambul village now had radios and that the construction of an electric power plant has been started there.<sup>71</sup>

Some letters, unsolicited or not, do appear to deal with the faults of radio and television. One such letter deals with a seemingly characteristic feature of Soviet life:

Some complaints are treated with complete indifference by officials of the Tarusa City Executive Committee, although the complainants are well known people...

What do the complainants ask? They want the loudspeaker that is installed at the Tarusa Communications office to stop making noise. This loudspeaker, which works almost 24 hours a day, is so powerful that it can be heard

anywhere within a radius of five kilometres. The radio persecutes the citizen at every step; it invades the institutions, schools, and apartments. Incidentally, there are plug-in sets or radio receivers in all these buildings.

The complaints are placed in a folder, and the officials of the city executive committee say: "True, it is noisy. But the loud-speaker is operating according to instructions."<sup>72</sup>

Other letters deal with the content of programming:

The work day is over. On this winter evening Soviet people are using various forms of relaxation. Some go to the motion pictures, theatres or clubs, others rush to the skating rinks in the stadium and still others stay at home, in the circle of their families. Here the radio becomes immensely important.

How does the radio help us to relax?

Very interesting materials are broadcast from 7 to 10 p.m. For example, on February 3 we heard a concise talk on the creative work of V.G. Belinsky and a concert of interesting works.

Unfortunately, the broadcasts of certain local radio are by no means always satisfactory. The Kursk province broadcast takes a whole hour in the evening, but during this time we hear almost the same thing, over and over. For instance, on February 4, they broadcast for the nth time a long talk on the preparation of millet seed for spring sowing. Then came an article, again on an agricultural subject, written in stiff language. Next came material on how sugar beets and millets are grown at the Russia Collective Farm.

Often the broadcasts of Moscow radio also consist of long, dull, articles. Included in those drab materials are reports from Moscow Polytechnic Museum about the exhibition of students' works.

We all like radio very much. We ask the editors to show some love also in preparing materials for us radio listeners.<sup>73</sup>



It seems there is some objection to the educative and motivating orientation of the programming of Soviet radio! Comments on specific bad television programs, we are told, often take the form of telephone calls, usually before the program is over. Comments on good programs usually come in letters.

Questionnaires administered to listeners seem to be one of the most rare forms of audience feedback, and usually are limited to radio. Several directors of youth programs have sent out questionnaires asking for comments on the future broadcasts listed. Another instance of the use of this method was a follow-up of a conference of listeners and broadcasting personnel, in which the questionnaire was designed to elicit responses from the audience as to which programs the listeners wished the diffusion exchange to carry.<sup>74</sup>

Little mention has been made in recent Soviet periodicals concerning the listeners conferences and visits to subscribers' homes and collective listening points. This may be due to the decline of collective listening. We also have scanty information on the pre-testing of programs. Letters, in addition to being answered on the air, are sometimes answered by mail, and provide a private means of contact between the audience and the broadcasting personnel.

Our second source, that of the time budgets of workers, studies which have been carried out by Soviet social scientists, yield a great deal of information on the time spent watching television, and/or listening to radio. These studies have become increasingly related to the reduction of the

working day to seven hours in some areas of the country. The effects of this increased leisure time on media behavior have been indicated in some of the studies. In data obtained at the Moscow Tire Factory, for example, the number of workers who daily watched TV or listened to the radio increased by 20 per cent.<sup>75</sup> In this study, it was also revealed that 1.9 times as many men watch television or listen to the radio as do women in that factory.

A second study,<sup>76</sup> carried out in 1961 in the city of Stalinsk studied the non-working time of workers of three industrial concerns. Five hundred and sixty-eight persons were interviewed. In examining the types of leisure time activities preferred, it was indicated that older persons tended to enjoy the more passive forms of recreation, such as listening to the radio or watching television. No proportions as to age were given, however. The study yielded the following information about radio listening:<sup>77</sup>

<u>Weekday</u>	<u>Total Free Time</u>	<u>Time Spent Listening to Radio</u>
Women	3 hrs, 55 min.	--
Men	7 hrs, 14 min.	15 min.
<u>Free Day</u>		
Women	11 hrs, 28 min.	8 min.
Men	12 hrs, 47 min.	42 min.

Another study<sup>78</sup> examined the non-working time of the engineering-technical staff of the Kuznets Metallurgical Factory. These employees spent the following amounts of

time listening to the radio:<sup>79</sup>

	<u>Number of Budgets Examined</u>	<u>% of Free Time Listening to Radio</u>	<u>Amount of Time Listening to Radio</u>
Weekday	519	34.9% of 5hrs. 17 min.	1 hr. 49 min.
Free day	109	32.3% of 3hrs. 49 min.	1 hr. 14 min.

The group of budgets examined for the two types of days has not influenced the amount of time spent listening in proportion to the amount of free time. Because the average amount of free time is much lower in the second group, even though it is for a free day, it would appear that workers actually spent less time listening to the radio on free days; this is probably not the case.

One of the most interesting studies,<sup>80</sup> if only because it deals with a traditionally neglected segment of Soviet society, the rural sector, is one which was carried out in April of 1960. A group of personnel from the Scientific Research Institute of Labor investigated the time budgets of two collective farms in Kherson Oblast in the Ukrainian SSR (named "Kirov" and "Novaya Zhizn" or "New Life") and two collective farms in Altai Krai, RSFSR, ("Rodina" or "Homeland," and "Zavety Il'icha" or "Lenin's Legacy"), on one weekend and one free day. The time budgets of 496 collective farmers (250 families) were investigated, of which 268 were in Kherson Oblast and 228 in Altai Krai. The sample included 276 women (55.5 per cent) and 220 men (44.5 per cent). Within each region, one progressive farm ("Kirov" and "Rodina") and one backward farm ("Novaya Zhizn" and "Zavety Il'icha") was chosen to determine how the structure of time budgets

changed, depending on the prosperity of the farm, and the amount of cultural service available. Unfortunately, the results of this aspect of the comparison were not included in the published version of the article. It was impossible, therefore, to draw any conclusions for the use of media on the two different types of farms.

On the whole, women tended to participate in those activities which could be called passive, such as radio, television, and visiting. Men, on the other hand, engaged in training and self-education, reading (three times as much as women), movies and clubs. This may be due to the smaller proportion of free time available to women after the completion of domestic chores. The following specific information was indicated:<sup>81</sup>

Radio Listening and Television Watching--% of Free Time

	<u>Men</u>	<u>Women</u>
Weekday	11.3%	16.4%
Free day	5.1%	6.1%

Other studies were carried out on workers in Kiev, the Ukrainian SSR, and in other areas, but most of these studies did not yield specific information on media behavior. A recommendation by social scientists in 1960 reviewed some suggestions on methodology in conducting leisure time studies. These resolutions indicated the desirability of gathering more specific information on time spent with radio and television.<sup>82</sup>

By far the most fruitful study for our purposes was

that carried out by the Laboratory of Sociological Studies of the Department of Philosophy of Leningrad State University in late 1960.<sup>83</sup> The subjects of the study were workers in the tool and die shop of the Kirov Plant in Leningrad. One hundred weekly (or 700 daily) time budgets were collected from the group. The table on the following page summarized the information resulting from the study which is pertinent to time spent with radio and television. The priority level of television in leisure time activities can be seen from the following data:

- (1) Study--largest item--18.5% of total free time.
- (2) Receiving guests, walks without children, conversations with friends, 16.6%
- (3) Reading literature--14%
- (4) Watching television--12.5%
- (5) Civic activity, time with children, visits to movies and theatres, 5-6% each.

As a whole, it was found that workers spent more time on study and, in consequence, spent less time visiting and watching television. Engineering and technical personnel have less free time, since they have less rigid work schedules, but spend a greater proportion of that free time watching television. The importance of television was noted in the study itself:

The television has become a part of normal life. Thus, of the 100 persons surveyed, 67 watch television in the course of a week. It would appear that in large cities television is becoming one of the major forms of cultural influence upon the masses, and is pushing the motion picture theatres into second place...This emphasizes once again the need for a carefully thought out utilization of television as an important means of educating and bringing culture to the masses.<sup>84</sup>

**Time Spent Watching Television by Personnel of the Kirov  
Plant Tool and Die Shop, Leningrad (per week)**

Classification	Category	Number in Sample	Number of Minutes = 1% of Free Time	% of Free Time Spent Watching Television Per Week	Actual amount of Time Spent Watching Television per week.
Type of Personnel	worker	62	26	12.1	5 hr. 15 min.
	ITR & OE *	38	21	16.8	5 hr. 53 min.
Type of Personnel in age grp. 31-40	worker	--	26.3	10.6	4 hr. 39 min.
	&OE*	--	22.4	16.0	5 hr. 58 min.
Sex	male	71	25.4	14.7	6 hr.
	female	29	22.1	10.6	3 hr. 5 min.
Age Group	18-30	46	26.9	10.8	4 hr. 54 min.
	31-40	22	23.9	13.6	5 hr. 24 min.
	40 +	32	21.2	19.3	6 hr. 39 min.
Present Educational Commitment	A *	30	29.7	6.1	3 hr.
	B *	36	22.1	14.4	5 hr. 18 min.
	C *	34	22.8	21.5	8 hr. 10 min.
Political Affiliation	Party	40	2	16.1	6 hr. 29 min.
	Komsomol	24	8.0	7.5	3 hr. 30 min.
	Non-Party	36	22.6	15.8	5 hr. 57 min.
Family Status	Family	36	--	18.3	--
	No Family	64	--	7.0	--
Education	Elem.	6	--	8.4	--
	7-year	41	--	17.5	--
	Secondary	45	--	12.5	--
	Higher	8	--	5.4	--
Relationship to movement for "Communist labor"	Shock-worker	29	--	10.4	--
	non-s. wkr.	33	--	15.5	--

\* ITR= technical personnel; OE=office employee; A=Schools for Working Youth, preparatory school courses, colleges; B= Political education courses; C= Non-students.

Footnotes

1. Alex Inkeles, Public Opinion in Soviet Russia (Cambridge, Harvard University Press, 1958), ch. 16.
2. V. Belikov, "Welcome Innovation," Izvestia, May 7, 1962, p. 4.
3. S.V. Kaftanov, ed., Radio i Televidenniye v SSSR, (Radio and Television in the USSR), (State Committee on Radio Broadcasting and Television of the Council of Ministers USSR, Moscow, 1961) Joint Publications Research Service translation, 4838 3 August 1961, pp. 194-5.
4. Ibid., p. 195.
5. Radio Liberty Broadcasting Map, April 1963
6. Kaftanov, op. cit., pp. 187-9.
7. V. Vinogradov, "Development of Television Broadcasting in the USSR," Radio (Moscow) No. 6, 1963, p. 32., and "12,000,000 Blue Screens", Pravda, December 4, 1964, p. 6 (The total cited is 400 stations.)
8. N. Bogdanov and B. Vyazimsky, Spravochnik Zhurnalista (The Journalist's Handbook), (Lenizat, Leningrad, 1961), p. 166.
9. Although the studios are large, the opinion of visiting American technical personnel is that they are not being used to their full potential. During working hours on a typical weekday, for example, over half of the studios are idle.
10. Author's interview with studio personnel.
11. Kaftanov, op. cit., pp. 203-4.
12. Ibid.
13. "National Television Center in Moscow," Moscow News, September 7, 1963, p. 4.
14. Vinogradov, op. cit.
15. Author's interview with studio director.
16. Kaftanov, op. cit., p. 238.



17. For the past several years there has been some speculation as to which color television system the Soviet Union should adopt. Indications in private conversations with Soviet technical and organization television personnel have been that they inclined toward the compatible American system, N.T.S.C.. Europe has not yet adopted a uniform system, however, and therefore the Soviet Union has abstained from adopting any one system, since it did not want to incur the vast expenditures involved in a subsequent switch-over to the European system. The German system, PAL, a modification of the American system, and the French system, SECAM, are the major contenders for European adoption. Just recently, in fact only a few days before the Vienna Conference, which was to make some decisive moves on adoption of a European system, the Soviet Union signed an agreement with France for the development of a mutual color television system; in other words, in the political dispute, the Soviet Union has allied with France. What effect this move will have on the choice of an official color television system for Europe is yet unknown. Additional discussion can be found in Mooney, Richard E., "Soviet Endorses French Color TV," New York Times, March 22, 1965, p. 1.
18. Kaftanov, op. cit., pp. 205-6.
19. Ibid., pp. 179-184.
20. Radio Liberty Research Notes#1369 on article in Sovetskaya Byelorussia, June 27, 1962
21. B. Kuibyshev, "Uskorit Radiofikatsia Sel" (Speed Up the Radiofication of the Farm), Pravda, July 18, 1958, p. 2.
22. A.I. Popov, "On the State of Cultural Service to the Population and Measures to Improve Them", Pravda, October 26, 1960, p. 2.
23. A. Sokolov, "Radio v Kazhduyu Semyu" (Radio in Every Family) Pravda, May 7, 1959, p. 2.
24. "Improve Trade in Rural Areas," Pravda, August 22, 1962, pp.1,4.
25. . . Konovalev, "Na Khutorakh" (On the Farmsteads) Izvestia, September 13, 1959, p. 4.
26. Kuibyshev, op. cit.
27. "Radio Day," Izvestia, May 7, 1959, p. 1.
28. Alex Yashin, "Vologodskaya Svadba" (Vologod Wedding) Novy Mir, December 1962, p. 11.

29. Private interview.
30. See Table I K, Appendix, for characteristics, service fees, and prices of some Soviet radio sets. Additional information may be found in the following sources:
- a. Andreiev, I.V., Radio Tovari (Radio Products), State Publishing House for Trade Literature, Moscow, 1962 (Also gives information on organization of the sale of radio products).
  - b. Gartsberg, M.V., Radioly, Magnitoly, i Magnitoradioly (Radio-Phonographs, Tape-Recorders/Phonographs, and Tape Recorder/Radios) Publishing House "Energiya," Moscow-Leningrad, 1964.
  - c. Popolnitelnyi Preiskurant (Supplementary Price List) Nos. 084/106 and 084/94, entitled "Rosnichniye Tseny na Radio Tovary" (Retail Prices for Radio Products), Published by GOSPLAN, USSR.
  - d. Koltsov, B.V., and Molokanov, P.L., Skhem, Uzly, i Detaly Priyomnikov na Tranzistorakh (Schematics, Assemblies, and Parts of Transistor Radios), State Energy Publishing House, Moscow-Leningrad, 1962, Edition 432 of the of the Mass Radio Library.
31. Transistor Portables are probably the most vogueish status symbols in Soviet society today; those who own them carry them about on the street at all times during good weather, and beaches are crowded with the noises from various pocket radios. Reports have been heard of counter-measures taken by those who are not such lovers of public music--portable pocket jammers which can disturb reception on the small radios to an extent that an owner will probably turn off his set.
32. The short life span of Soviet batteries has been a real problem among owners of transistor radios. In addition, most Soviet dry cell batteries and "accumulators," are large in size. This has caused a real problem for those who acquire Japanese or European transistor portables, normally use a 9-volt light weight small battery. Recently a nine-volt battery has been released, the "Krona;" it is, however, extremely popular and difficult to obtain. It is not unusual to see a small radio with many large batteries taped to its case. These batteries often last only a few hours.
33. O. Rupsky, "The Country from Midnight to Noon: Interesting Experiment," Izvestia, January 1, 1963, p. 4.
34. All information on new and future models from Noviye Tovary (New Goods), No. 9, 1963, pp.2-3, and from personal observation in the Soviet Union.
35. "Proyektiruyem semi," (Let's Design), Komsomolskaya Pravda, June, 1964, p. 4.

36. "Proyektiruyem sami," Kom. Pravda, September 12, 1964, p. 4.
37. "Proyektiruyem sami," Kom. Pravda, October 28, 1964, p. 4.
38. Pivivarov, Yu., "Letter," September 12, 1964, p. 4.
39. Krokodil, no. 8, 1958, p. 15 and Pravda Vostoka, February 24, 1959, p. 4.
40. "When Will Excessive Certification be Stopped?" Izvestia, July 26, 1958, p. 2.
41. "Gift to Ten Thousand," Izvestia, August 27, 1961, p. 6.
42. Moskva v 1962 (Moscow in 1962, a Short Address-Information Handbook) Moscow, 1962.
43. Matvyev, "Television Service Problems," Ekonomicheskaya Gazeta, no. 44, October 27, 1962, pp. 7-8.
44. Soloveichik, A.I., Spravochnik Telezritelya (TV Viewer's Handbook), "Svyaz" Publishing House, 1964, p. 17.
45. In a study of American television owners, the question was asked of viewers "Altogether, about how long were you without a television set?" (Reference is to absence of the set due to repair.) Answers indicated that the owners either replaced the sets or had them repaired within the following time periods:  
half a day-26%  
one a day- 47%  
Even though the television was not listed as one of the basic essentials of life by owners, the loss of the set, even for a short time period, seemed almost tragic: "When it is out of order, I feel like someone is dead." see Gary A. Steiner, The People Look At Television, A. Knopf, New York, 1963, p. 25.
46. "Soviet Television Sets Should be the Best in the World," Ekonomicheskaya Gazeta, July 18, 1961.
47. T.M. Hannah, "Soviet Radio and Television Sets," Electronics World, March 1961, pp. 7-50.
48. N.S. Khrushchev, "The Development of the Soviet Economy and the Party Guidance of the National Economy," Speech to the Plenary Session of the Central Committee of the Communist Party of the Soviet Union, November 19, 1962, Moscow News, supplement section, November 24, 1962.

49. Bogdanov, op. cit., p. 150.
50. Mesyatsev's background indicates his experience as an executive and organizer. He served in the Red Army from 1940-1945. As a student of the Faculty of History at Moscow University, he held leading posts in the university's Komsomol (Communist Youth League) organization, until his graduation in 1951. From 1951 to 1953, he was a member of the editorial board of the newspaper KOMSOMOLSKAYA PRAVDA, and worked for the publishing house "Molodaya Gvardia." From 1953-1955, he was a member of the Moscow Oblast Committee of the Komsomol, and from 1955 to 1959, he was deputy director, then secretary, of the Central Committee of the All-Union Komsomol, and worked on various youth festivals, including Vienna, Belgium, and Bulgaria. In 1955, he was also a member of the editorial board of the All-Union Komsomol publication "Molodoi Kommunist." He was also co-publisher and author of the "Studentcheskaia Molodyozh." In 1960, he was First Deputy Chairman of the All-Union Society for the Dissemination of Scientific and Political Knowledge. In 1961, he was one of the chairmen of the Council of Founders of the Novosti Press Agency.
51. Kaftanov, op. cit., p. 149.
52. All information herein is a combination of data from pages 34-38 of Kaftanov op. cit., the memorandum entitled "An Eight-day Analysis of New Programmes on the Soviet Radio," of Radio Liberty Monitoring Section, October 25, 1962, and personal observation by the author.
53. "Govorit 'Mayak'," (" 'Mayak' Speaking") Pravda, August 17, 1964, p. 6.
54. Richard Tuber, "A Survey of Programming on the Central Studios of Television, Moscow, USSR, January-June 1960," Journal of Broadcasting, Fall, 1960, pp. 315-325.
55. William Benton, "ETV-Will the Soviet Surpass Us?" Typescript, p. 1.
56. Ibid.
57. Author's interview with studio director.
58. Kaftanov, op. cit., p. 162.
59. Ibid., p. 207.

60. Ibid., p. 214.
61. Pukhamenko, V. I. and Spirin, A. G., "Experience Gained with Practical Operation of KADR Video Tape Recorders and the Soviet Central Television," Radio and Television, 1954, No. 2, p. 28. Technical data on the machine are given on pages 28-29 of this article.
62. Ibid.
63. "Creation of Intervision," Radio and Television (Journal of OIRT, International Radio and Television Organization, Prague) no. 2, 1960.
64. "Experience in the Technical Operation of the Intervision Network," Radio and Television, OIRT, Prague, no. 2, 1963, p. 26.
65. "Television in the Soviet Bloc" R.N. (R.L.) No. 2025, April 25, 1963.
66. "Transmitted by Intervision" Sovetskaya Kultura, December 8, 1962, p. 2.
67. "12,000,000 Blue Screens," Pravda, December 30, 1963, p. 4.
68. "Television and Everyday Life," Moscow News, No. 18, May 4, 1963, pp. 8-9.
69. Kaftanov, op. cit., p. 105.
70. Ibid., p. 107.
71. Ibid., p. 108.
72. V. Zhuralev, "Noise By Order," Izvestia, October 2, 1959, p. 3.
73. M. Kovrishin, "Tuning in from 7 to 10 p.m. Helps Us to Relax," Izvestia, February 12, 1960, p. 3.
74. Inkeles, op. cit., p. 282.
75. A study carried out by the Institute of Scientific Labor Research in 1960-61. Discussed in L. Bibik and M. Markevich, "Changes Occurring in the Structure of Free Time," Politicheskoye Samoobrazovanie, 1962, No. 7.

76. The industrial concerns were the Kuznetsk Metallurgical Combine, the Ordzhonikidze Mines, and the Kuznetszhiłstroi Trust. Yu. S. Shein, "Experience of the study of Non-working Time of Laborers in Industry of the City of Stalinsk," in Prudenskiy, G.A., Vnyerabochaya Vremya Trudyashchikhsya (Non-working Time of Laborers) Novosibirsk, 1961, pp. 157-164.
77. Shein, op. cit., Table 4, p. 163: "Use of Free Time by Young Workers (45 budgets) and Workers (63 budgets) on Weekdays and Free Days."
78. A.I. Borodulin and D. Ya. Yashin, "The Free Time of Kuznets Metallurgists," in Prudenskiy, op. cit.
79. Borodulin, op. cit., Table 5, p. 95.
80. L. Bibik, "An Attempt to Study the Time Budgets of Collective Farmers," Byulletin Nauchnoi Informatsii: Trud i Zarabotnaya Plata (Bulletin of Scientific Information: Labor and Wages) Moscow, No. 6, 1961, pp. 45-52.
81. Bibik, op. cit., Table 4, p. 197.
82. In Prudenskiy, op. cit., the section entitled "Instructions of the Investigation of Time Budgets of Workers, Engineering-Technical Personnel, and Employees," there is a blank form suggested for use in the study of time budgets. On page 238, under the heading "Cultural-Domestic Inventory," there are spaces for indicating whether the family owns a radio or television set. On p. 244, "Rest and Education," there are places for listing the number of minutes per day spent on each of the six working days, and on the free day, listening to radio, and watching programs on television.
83. E.V. Beliaev, V.V. Vodzinskaia, A.G. Zdravomyslov, B.V. Ornatskiy, A.S. Shaev, V.A. Iadov, "Workers' Time Budget Research: A Method of Concrete Sociological Investigation," Vestnik Leningradskovo Universiteta, Seriya Ekonomiki, Filosofii i Prava, (Bulletin of Leningrad University, Economics, Philosophy and Law Series), 1961, No. 4.
84. Beliaev, op. cit., p. 47.
85. Ibid., compiled from various tables in the article.

(95)

**Appendices**

## I.A. Number and Types of Receiving Sets, 1959-1963, by Union Republic

Republic	Year	Population	Total number of receiving sets	Number of Wired Sets	Wave Sets	Television Sets
Total USSR	1959	208,826,650	52,800,000	29,000,000	20,200,000	3,600,000
	1960		62,600,000	30,800,000	27,000,000	4,800,000
	1961		69,000,000	32,000,000	30,500,000	6,500,000
	1962	216,000,000*	73,000,000	33,000,000	32,000,000	8,000,000
	1963		30,000,000	17,000,000	11,000,000	2,000,000
RSFSR	1959	117,534,315	40,000,000	18,405,000	16,900,000	4,000,000
	1960		42,500,000	19,000,000	18,000,000	5,000,000
	1961	121,000,000*	9,187,000	6,618,000	2,569,000	
	1962		14,000,000	7,203,000	3,200,000	
	1963	41,869,046	1,400,000	7,631,000	3,500,000	2,500,000
Ukrainian SSR	1959	8,054,648	1,469,000	1,171,000	291,000	
	1960		1,950,000	1,253,000		
	1961	3,500,000*	491,000	1,322,000	340,000	62,000
	1962		563,000	1,400,000	400,000	150,000
	1963	2,834,477	359,000		132,000	21,000
Moldavian SSR	1959	2,834,477	473,000	178,000	250,000	50,000
	1960			133,000		
	1961	3,000,000*		186,000	415,000	
	1962					
	1963	2,093,453				
Latvian SSR	1959	2,093,453	375,000	163,000	200,000	15,000
	1960		616,000	167,000	270,000	21,000
	1961	3,000,000*		169,000		
	1962					
	1963	2,711,445	295,000	79,000	216,000	66,000
Lithuanian SSR	1959	1,196,791	417,565	81,000	225,000	38,000
	1960		511,000	83,000		53,000
	1961	1,500,000*				
	1962					
	1963	4,044,045				
Estonian SSR	1959	4,044,045		309,000	150,000	52,000
	1960			320,000		
	1961	4,500,000*		332,000	200,000	
	1962				217,000	
	1963	3,697,717	553,000	306,000	247,000	
Georgian SSR	1959	3,697,717				
	1960					
	1961					
	1962					
	1963					
Azerbaijani SSR	1959					
	1960					
	1961					
	1962					
	1963					





Notes to TABLE I.A.

1. Upon examination of the total figures for USSR, it will be seen that they sometimes differ from those totals for the Union Republic figures (not calculated on table). In both cases, official Soviet statistics have been used. In 1959, for example, the official USSR figure for the total number of receiving sets was 57,500,000; the total of the Union Republic figures is 46,893,000. In some cases, discrepancies are merely the result of figures being presented in rounded form.

2. In regard to the statistics on the number of wave sets in 1962, most of the figures used were those made available by Mr. Max Ralis, of Radio Liberty. His statistics indicate that the sum of the Union Republic figures is approximately half that for the USSR. Official statistics are available only for the RSFSR for that year. The official figure of 16,900,000 is considerably greater than the 11,200,000 used by Mr. Ralis. If other official republic figures are in keeping with this one, the result would no doubt be that the total of the Union Republic figures would be much closer to the official USSR total. Whatever discrepancy may then exist would perhaps be due to the fact that non-civilian sets (i.e., military, etc.) would be counted into the total USSR figure, whereas they would be omitted from the Union Republic statistics. The amount of television sets for non-civilian use remains, however, a matter for speculation.

3. Figures in the table marked by an asterisk have been estimated on the basis of statistics for previous years; for example, the 1962 population figures are approximate projections of the 1959 population census statistics.

4. Soviet expectations for the number of television sets by the end of 1963 and 1965 are 11,000,000 and 15,000,000, respectively.

---

\*From RSFSR v 1962 (Statistical Handbook), Gosstatizdat, Moscow, 1962. In addenda, the Narodnoye Khoziasstvo RSFSR v 1961 (Moscow, 1962) gives an even higher figure for the RSFSR--17,051,000.

Sources of data in Table I.A.

Narodnoye Khoziaistvo v 1961, Moscow, 1962.

Press articles on annual Radio Day.

Radio Liberty Research Notes.

Results of the All-Union Population Census, 1959, Central  
Statistical Administration, Moscow, 1959.

RSFSR v 1962 (Statistical Handbook), Moscow, 1962.

I-B. Number of Receiving Sets Available for Sale to the Soviet Population (in thousands)

Radio Sets (Wave) and Radio-photograph combinations

Year	Total Population	To Rural Population
1952	1,247	395
1958	3,086	1,449
1959	3,888	1,377
1960	4,051	1,561
1961	4,132	1,498
1962	4,068	1,390

Note: Decline in number of available sets in 1962.

Television Sets

1952	68	0.3
1958	912	74
1959	1,132	122
1960	1,528	212
1961	1,803	258
1962	1,997	353

Source: Narodnoye Khoziastvo v 1962, SSSR, p. 490.

I.C. Production of Receiving Sets, USSR

Year	Wave Radio and Radio-Phonographs	Television Sets
1952	1,296,000	37,400
1958	3,902,000	979,000
1959	4,035,000	1,277,000
1960	4,165,000	1,726,000
1961	4,228,000	1,949,000
1962	4,251,000	2,168,000
1964 plan	5-6,000,000	3,000,000

Sources: Narodnoye Khoziastvo v 1962, SSSR, Moscow, 1963, pp. 126-202.

1964 plan figures from Noviye Tovari (New Products) No. 9, 1963.

I.D. Discrepancies Between Official Figures on Radio and Television Sets: Produced, in Existence, and Available for Sale to Total Population

Year	Number of Sets Produced	Increase in No. of Existing Sets	Number of Sets for Sale to Total Population
------	-------------------------	----------------------------------	---

Radio Wave Sets and Radio-Phonograph Combinations

1952	1,296,000	-----	1,247,000
1958	3,902,000	-----	3,686,000
1959	4,035,000	3,000,000	3,888,000
1960	4,165,000	3,100,000	4,051,000
1961	4,228,000	2,700,000	4,132,000
1962	4,251,000	2,300,000	4,068,000

Television Sets

1952	37,400	-----	68,000
1958	979,000	-----	912,000
1959	1,277,000	1,100,000	1,132,000
1960	1,726,000	1,200,000	1,528,000
1961	1,949,000	1,700,000	1,803,000
1962	2,168,000	1,800,000	1,997,000

Sources: Narodnoye Khoziastvo v 1962 SSSR, Moscow, 1963.

Column one--pp. 126, 202.

Column two--p. 422.

Column three--p. 490.

I.E. Number and Type of Radiobroadcasting Stations USSR1963\*

Republic:	Long Wave	Medium Wave	Short Wave	FM
RSFSR	31	31	33	35
Latvian SSR	0	4	0	2
Estonian SSR	0	4	1	4
Lithuanian SSR	0	2	1	6
Byelorussian SSR	2	0	1	2
Ukrainian SSR	2	14	1	20
Moldavian SSR	0	1	0	2
Georgian SSR	1	1	4	2
Armenian SSR	1	1	1	2
Azerbaijani SSR	0	1	1	2
Turkmenian SSR	1	1	1	1
Uzbek SSR	3	0	1	2
Tadzhik SSR	2	0	3	3
Kirghiz SSR	0	1	1	0
Kazakh SSR	3	1	12	3
Total USSR	47	62	61	86

\* From information in RADIO LIBERTY map of April, 1963.

I.F. Number of Television Centers in the USSR, 1952-1962

Year	Total Number of TV Centers and Relay Stations	Of That, Number of TV Centers & Large Relay Stations
1952	3	3
1958	139	62
1959	210	84
1960	275	100
1961	347	116
1962	397	130

Narodnoye Khoziastvo v 1962 SSSR, p. 422, Moscow, 1963.

I.G. PRINCIPLE TELEVISION STUDIOS IN OPERATION IN THE USSR  
During November of 1959

Name	Date of opening (month, year)	Frequency Channel (number)	Number of Studios	Size of studios (sq.m.)	Number of Television Channels	Days per week on the air				Total amt. of time on air acc. to 1959 plan (in hrs.)	Including	
						4th quarter 1959		4th quarter 1960			Studio broadcasts	On sp. broadcasts
Central (city of Moscow)	4/51	(b/w) * 1 & 3 ** 8 (col)	5	600;300; 180;150; 60	20	7	6'5"	7	8'45"	3000	1450	7
RSFSR												
Arnavirskaya	2/59	1	1	30	2	4	1'55"	5	2'40"	388	52	--
Barnaul'skaya	10/56	3	1	50	4	5	3'10"	6	3'6"	825	170	--
Biyskaya	4/57	1	1	120	4	5	2'40"	5	3'15"	697	140	--
Bryanskaya	3/59	2	1	20	2	5	1'40"	7	5'25"	445	42	--
Vakutinskaya	1/59	3	1	200	3	5	2'	6	3'5"	535	90	--
Voronezhskaya	10/56	1	2	300;50	4	6	3'30"	7	4'55"	1113	215	--
Vladivostokskaya	12/55	1	1	150	4	5	3'10"	6	3'5"	825	190	--
Gorkovskaya	8/57	2	2	250;40	5	6	3'	6	3'30"	957	225	12
Izhevskaya	10/56	2	1	80	5	5	2'30"	6	3'6"	761	105	--
Irkutskaya	12/57	3	2	300;50	4	6	3'	6	3'30"	957	215	--
Kazanskaya	10/59	1	2	300;50	4	5	30"	6	3'10"	210	45	--
Kaliningradskaya	7/58	4	1	60	3	5	2'30"	6	3'5"	761	130	--
Kemerovskaya	3/58	5	2	300;50	4	6	2'25"	6	3'30"	748	130	--
Kirovskaya	2/58	3	1	100	3	6	2'40"	6	3'30"	853	180	--
Krasnodarskaya	7/57	5	2	300;50	4	6	3'	6	3'30"	957	210	--
Krasnoyarskaya	10/57	2	2	300;50	5	6	2'45"	6	3'30"	879	210	--
Kuybyshevskaya	2/58	3	2	290;45	4	6	3'30"	6	4'5"	1113	255	1
Leningradskaya	3/52	1	1	67, STRP ***	4	6	4'	6	4'55"	1270	475	2
Murmanskaya	11/57	3	1	100	3	6	2'50"	6	3'5"	879	165	--
Nal'chikskaya	2/57	1	1	50	2	5	2'30"	6	3'5"	761	175	--
Novosibirskaya	4/57	2	2	300;50	4	6	4'	6	4'55"	1270	345	1
Noril'skaya	8/59	1	1	100	3	5	1'30"	6	3'5"	396	40	--
Omskaya	5/55	1	2	250;40	3	6	3'	6	3'30"	957	215	--
Penzenskaya	10/58	4	1	200	4	5	2'30"	6	3'5"	761	130	--
Permskaya	4/58	1	2	300;50	4	6	2'40"	6	3'30"	853	165	--
Petrozavodskaya	4/59	2	1	200	4	5	1'40"	6	3'25"	435	60	--
Pyatigorskaya	10/59	2	2	300;50	4	4	40"	6	2'50"	147	25	--
Rostovskaya	4/58	1	2	280;60	5	6	2'55"	6	4'40"	930	205	10
Rubtsovskaya	8/57	2	1	100	4	5	2'35"	5	3'10"	697	130	--
Saratovskaya	12/57	1	2	300;50	4	6	3'30"	6	3'30"	1113	280	1
Sverdlovskaya	7/55	3	2	220;30	5	6	4'	6	4'54"	1270	355	2
Sochinskaya	4/59	1	2	300;50	4	5	1'40"	6	3'25"	430	85	--
Stalingradskaya	1/58	4	2	300;50	4	6	2'40"	6	3'30"	853	195	12
Stalinogorskaya	12/56	5	1	100	3	7	4'54"	7	5'25"	1790	57	--
Tomskaya	6/55	1	1	210	4	6	3'	6	3'30"	957	215	--
Tyumenskaya	7/58	2	1	60	2	5	2'40"	5	3'10"	697	115	--
Ul'yanovskaya	11/59	5	1	200	4	3	26"	5	2'35"	70	10	--
Ufinskaya	2/59	1	2	220;30	4	5	1'40"	6	3'25"	547	75	--
Cherepovetskaya	10/59	5	1	200	3	3	1'	5	2'35"	160	23	--
Chelyabinskaya	7/58	4	2	300;50	4	6	2'40"	6	3'30"	853	180	--
Yaroslavl'skaya	1/58	2	1	80	4	7	4'55"	7	5'25"	1790	125	--

\* (b/w) - black-white image

\*\* (col) - color image

\*\*\* STRP - stationary television relay point



N THE USSR

Number of Television Channels	Days per week on the air		Total amt. of time on air acc. to 1959 plan (in hrs.)	Including		Total amt. of time on air acc. to 1960 plan (in hrs.)	Including		Amount of film photographed by studio (in hours)			
	4th quarter 1959	4th quarter 1960		Studio broadcasts	On the spot broadcasts		Studio Broadcasts	On the spot broadcasts	1959	1960		
20	7	6'5"	7	8'45"	3000	1450	770	5234	1455	770	222	298
2	4	1'55"	5	2'40"	388	52	--	701	130	--	--	6
4	5	3'10"	6	3'6"	825	170	--	963	220	--	4	14
4	5	2'40"	5	3'15"	697	140	--	833	160	--	2	8
2	5	1'40"	7	5'25"	445	42	--	2000	60	--	--	5
3	5	2'	6	3'5"	535	90	--	963	160	--	2	10
4	6	3'30"	7	4'55"	1113	215	--	1805	240	60	6	14
4	5	3'10"	6	3'5"	825	190	--	963	220	--	7	14
5	6	3'	6	3'30"	957	225	120	1120	260	160	4	14
5	5	2'30"	6	3'6"	761	105	50	963	190	80	5	12
4	6	3'	6	3'30"	957	215	50	1120	260	80	4	14
4	5	3'50"	6	3'10"	210	45	--	1002	200	80	1.5	14
3	5	2'30"	6	3'5"	761	130	--	963	200	60	5	14
4	6	2'25"	6	3'30"	748	130	50	1120	240	120	2	14
3	6	2'40"	6	3'30"	853	180	--	1120	260	--	2	14
4	6	3'	6	3'30"	957	210	25	1120	260	60	10	18
5	6	2'45"	6	3'30"	879	210	50	1120	260	140	6	18
4	6	3'30"	6	4'5"	1113	255	120	1280	340	160	6	25
4	6	4'	6	4'55"	1270	475	240	1340	430	240	56.5	87
3	6	2'50"	6	3'5"	879	165	30	963	200	70	6	14
2	5	2'30"	6	3'5"	761	175	--	963	220	--	3	8
4	6	4'	6	4'55"	1270	345	100	1340	430	240	13	35
3	5	1'30"	6	3'5"	396	40	--	963	145	--	1	10
5	6	3'	6	3'30"	957	215	50	1120	240	90	8	14
4	5	2'30"	6	3'5"	761	130	25	963	220	--	5	12
4	6	2'40"	6	3'30"	853	165	80	1120	260	120	4	14
4	5	1'40"	6	3'25"	435	60	10	1080	200	--	3	14
4	4	40"	6	2'50"	147	25	--	866	200	--	1	12
5	6	2'55"	6	4'40"	930	205	190	1457	340	160	6	24
4	5	2'35"	5	3'10"	697	130	--	833	160	--	5.5	14
4	6	3'30"	6	3'30"	1113	280	120	1120	280	160	7.5	18
5	6	4'	6	4'54"	1270	355	240	1340	430	240	14	35
4	5	1'40"	6	3'25"	430	85	--	1080	240	--	7	14
4	6	2'40"	6	3'30"	853	195	120	1120	260	160	9.5	23
3	7	4'54"	7	5'25"	1790	57	--	2000	60	--	5	7
4	6	3'	6	3'30"	957	215	--	1120	220	--	8.5	23
2	5	2'40"	5	3'10"	697	115	--	833	145	--	--	9
4	3	2'5"	5	2'35"	70	10	--	688	130	--	--	5
4	5	1'40"	6	3'25"	547	75	15	1080	200	60	3	14
3	3	1'	5	2'35"	160	23	--	688	130	--	--	6
4	6	2'40"	6	3'30"	853	180	80	1120	260	160	10	18
4	7	4'55"	7	5'25"	1790	125	--	2000	100	--	10	12

## I.G. Television Studios in Operation in the USSR, 1959

Name	Date of opening (month, year)	Frequency Channel (number)	Number of Studios	Size of studios (sq.m.)	Number of Television Channels	Days per week on the air				Total time on the air acc. to 1959 plan
						4th quarter 1959		4th quarter 1960		
<b>Ukrainian SSR</b>										
Dnepropetrovskaya	5/58	5	2	300;50	4	6	4'10"	6	4'30"	1319
Zaporozhskaya	4/59	6	1	100	3	6	4'20"	6	4'30"	1353
Kiyevskaya	11/52	2	2	300;180	8	7	4'	7	6'35"	1494
Luganskaya	6/58	2	1	100	3	6	3'40"	6	4'30"	1136
L'vovskaya	11/57	1	2	300;50	4	6	3'30"	6	4'30"	1104
Nikolayevskaya	8/59	2	1	80	2	6	2'20"	6	4'30"	730
Odesskaya	10/56	5	2	300;50	4	6	3'30"	6	4'30"	1104
Stalinskaya	8/56	4	2	280;60	5	6	3'30"	6	4'30"	1104
Simferopol'skaya	1/59	3	2	300;50	4	6	1'35"	6	4'	522
Khar'kovskaya	4/55	3	2	210;45	5	6	4'	7	5'25"	1260
Khersonskaya	4/59	3	1	80	2	6	3'20"	6	4'30"	1043
<b>Belorussian SSR</b>										
Gomel'skaya	1/58	3	1	30	1	4	2'45"	5	2'24"	575
Minskaya	7/55	1	3	290;90;40	8	6	3'30"	7	3'25"	1111
<b>Kazakh SSR</b>										
Alma-Atinskaya	4/58	3	2	290;45	8	6	2'50"	6	3'10"	990
Karagandinskaya	10/58	1	2	300;50	4	5	2'55"	5	3'20"	770
Ust'-Kamenogorskaya	7/58	1	1	200	4	5	2'50"	5	2'50"	740
<b>Azerbaijan SSR</b>										
Bakinskaya	1/56	3	2	290;45	8	6	3'25"	6	3'55"	1076
<b>Lithuanian SSR</b>										
Vil'nyusskaya	2/57	4	2	340;50	5	6	3'20"	6	4'	1000
<b>Armenian SSR</b>										
Yerevanskaya	11/56	1	1	60	3	6	3'30"	6	3'25"	1070
<b>Moldavian SSR</b>										
Kushinevskaya	5/58	3	1	30	4	5	2'40"	5	3'35"	715
<b>Latvian SSR</b>										
Rizhskaya	4/55	3	2	310;35	5	6	4'15"	6	5'	1309
<b>Estonian SSR</b>										
Tallinskaya	7/55	2 & s	1	100 & the main radio station	5	6	4'55"	6	6'10"	1512
<b>Uzbek SSR</b>										
Tashkentskaya	11/56	3	2	325;45	8	7	3'	7	3'50"	1111
<b>Georgian SSR</b>										
Tbilisshaya	9/56	4	1	60	3	6	3'50"	6	4'	1211
<b>Kirghiz SSR</b>										
Frunzenskaya	1/59	1	1	200	4	4	2'20"	5	2'40"	480

Source: Radio i Televideniye v SSSR, S.V. Kaftanov et. al., eds., Moscow, 1961.

Days per week on the air				Total time on the air acc. to 1959 plan	Including Studio On the spot broad- broadcasts casts		Total time on the air acc. to 1960 plan	Including Studio On the spot broad- broadcasts casts		Film photo-graphed by studio (hrs.)	
4th quarter 1959	4th quarter 1959	4th quarter 1960	4th quarter 1960								1959
6	4'10"	6	4'30"	1319	200	190	1416	300	150	5	20
6	4'20"	6	4'30"	1353	65	--	1416	150	--	--	6
7	4'	7	6'35"	1494	500	250	2416	550	300	51	98
6	5'40"	6	4'30"	1136	91	--	1416	150	--	--	11
6	3'30"	6	4'30"	1104	250	150	1422	400	200	8	25
6	2'20"	6	4'30"	730	50	--	1416	150	--	--	6
6	3'30"	6	4'30"	1104	250	150	1422	400	200	33	36
6	3'30"	6	4'30"	1104	345	150	1422	400	200	20	34
6	1'35"	6	4'	522	65	--	1260	220	100	--	6
6	4'	7	5'25"	1260	400	200	2012	450	250	32	42
6	3'20"	6	4'30"	1043	65	--	1416	150	--	--	6
4	2'45"	5	2'24"	575		--	642	130	--	--	52
6	3'30"	7	3'25"	1111	420	200	1270	443	250	19	--
6	2'50"	6	3'10"	990	210	160	998	310	152	14	16
5	2'55"	5	3'20"	770	182	83	878	200	100	3	11
5	2'50"	5	2'50"	740	170	10	740	170	--	3	5
6	3'25"	6	3'55"	1076	200	300	1232	300	330	9	16
6	3'20"	6	4'	1000	120	220	1296	250	300	11	22
6	3'30"	6	3'25"	1070	250	150	1076	250	160	19	30
5	2'40"	5	3'35"	715	170	100	950	220	140	5	9
6	4'15"	6	5'	1309	420	270	1570	460	280	13	22
6	4'55"	6	6'10"	1512	332	300	1924	400	300	36	41
7	3'	7	3'50"	1111	387	194	1410	423	253	14	24
6	3'50"	6	4'	1211	250	212	1270	318	250	25	40
4	2'20"	5	2'40"	480	70	--	720	130	70	4	5

., Moscow, 1961

I.H. Wired Sets in Rural Localities 1959-1961  
(millions)

Republic	Rural Population 1959	1959	1960	1961
USSR	108.850	15.094	16.130	16.723
RSFSR	55.9	8.028	8.397	8.623
Ukrainian SSR	22.722	4.000	4.418	4.761
Byelorussian SSR	5.574	.792	.857	.894
Uzbek SSR	5.377	.635	.679	.686
Kazakh SSR	5.243	.494	.537	.551
Georgian SSR	2.331	.158	.164	.165
Azerbaidzhanian SSR	1.930	.188	.209	.212
Lithuanian SSR	1.666	.078	.081	.082
Moldavian SSR	2.242	.274	.306	.338
Latvian SSR	.919	.066	.069	.069
Kirghiz SSR	1.370	.111	.124	.135
Tadzhik SSR	1.334	.093	.096	.104
Armenian SSR	.881	.072	.076	.070
Turkmenian SSR	.816	.079	.089	.095
Estonian SSR	.521	.026	.028	.028

Sources: Population: Results of the All-Union Population Census,  
Moscow, 1959, p. 17.

Other Figures from Narodnoye Khoziastvo v 1961 SSSR,  
p. 525.

1.1 Distribution of Television Channels by Television Centers, USSR  
(as of August, 1962)

Aktyubinsk . . . . .	1	Lugansk . . . . .	2
Astrakhan . . . . .	1	Magadan . . . . .	1
Armavir . . . . .	1	Minsk . . . . .	1
Ashkhabad . . . . .	1	Moscow . . . . .	1,3,5
Andiznan . . . . .	2	Murmansk . . . . .	3
Alma-Ata . . . . .	3	Nal'chik . . . . .	1
Biysk . . . . .	1	Norilsk . . . . .	1
Baku . . . . .	3	Nikolayev . . . . .	2
Barnaul . . . . .	3	Novosibirsk . . . . .	2
Voronezh . . . . .	1	Novgorod . . . . .	4
Vladivostok . . . . .	1	Namangan . . . . .	5
Bratsk . . . . .	2	Novomoskovsk . . . . .	5
Vorkuta . . . . .	3	Omsk . . . . .	1
Vilnyus . . . . .	4	Odessa . . . . .	1
Vladimir . . . . .	4	Perm . . . . .	1
Volgograd . . . . .	4	Petrozavodsk . . . . .	2
Gorkiy . . . . .	2	Pyatigorsk . . . . .	2
Gomel' . . . . .	3	Petropavlovsk (Kazan.SSR) . . . . .	3
Grozniy . . . . .	3	Penza . . . . .	4
Dzhezkazgan . . . . .	1	Rostov-on-Don . . . . .	1
Dushanbe . . . . .	1	Rubtsova . . . . .	2
Doretsk . . . . .	4	Ryazan' . . . . .	2
Dnepropetrovsk . . . . .	5	Riga . . . . .	3
Yerevan . . . . .	1	Saratov . . . . .	1
Izhevsk . . . . .	1	Sochi . . . . .	1
Irkutsk . . . . .	3	Sverdlovsk . . . . .	3
Ivanovo . . . . .	5	Simferopol . . . . .	3
Kazan' . . . . .	1	Salavat . . . . .	4
Karaganda . . . . .	1	Smolyensk . . . . .	5
Komsomolsk-on-Amur . . . . .	1	Tomsk . . . . .	1
Kuldiga . . . . .	1	Tallin . . . . .	2
Kalinin . . . . .	2	Tyumen' . . . . .	2
Kiev . . . . .	2	Tashkent . . . . .	3
Krasnoyarsk . . . . .	2	Tbilisi . . . . .	4
Kirov . . . . .	2	Ust'-Kamenogorsk . . . . .	1
Kishinyov . . . . .	3	Ufa . . . . .	1
Kolonna . . . . .	3	Ulyanovsk . . . . .	5
Kostroma . . . . .	4	Frunze . . . . .	1
Kuibyshev . . . . .	3	Khabarovsk . . . . .	3
Kaliningrad . . . . .	4	Kherson . . . . .	3
Kemerovo . . . . .	5	Chelyabinsk . . . . .	4
Krasnodar . . . . .	5	Cherepovets . . . . .	5
Leningrad . . . . .	1	Yuzhno-Sakhalinsk . . . . .	3
Lviv . . . . .	1	Yaroslavl' . . . . .	2

Source: Andreiev, I.V. et al, Radio-Tovari (Radio Products), State Publishing House for Trade Literature, Moscow, 1962, p. 116.

I.J. Distribution of Frequencies of Television Channels  
Used in the USSR

Television Channel	Carrier Frequency Visual Portion MC	Carrier Frequency Sound Portion MC
1	49.75	56.25
2	59.25	65.75
3	77.25	83.75
4	85.25	91.75
5	93.25	99.75
6	175.25	181.75
7	183.25	189.75
8	191.25	191.75
9	199.25	205.75
10	207.25	213.75
11	215.25	221.75
12	223.25	229.75

---

Source: Kuznetsov, L.M., Televizori (Television Sets), "Energia"  
Publishing House, Moscow-Leningrad, 1964, p.6.

I.K. Characteristics of Several Types of Soviet

Name	Number and Type of Bands	Number of Transistors (if any)	Sensitivity	Type Cabinet	Num Typ
<u>Portable Transistors</u>					
Spidola (Riga)	Seven: LW 150-410 KC. MW 520-1600 KD. SW 75-52, m 50 m 41 m 31 meters 25 meters**	10	LW - 2MV/M MW - 1MV/M SW - 200 microvolts	Black Yellow Plastic	Sev
Neva-2	Two: LW MW	7	LW - 3MV/M MW - 1.5 MV/M		** sa. do Tw
Atmosfera-2M	LW MW	8	LW - 3MV/M MW - 1.5 MV/M		
<u>Automobile</u> A-12 (for use in either "Volga" or "Moskvich")	LW MW				
<u>Radiola</u> Class IV- Serenada	LW MW 3-speed record player			Wood plastic Plastic	3-
Class III -Rekord C1	LW MW SW 2 speakers 3-speed			Wood	2 3-
Class II- Melodia	LW MW 2 SW 1 USW			Lacquered wood plastic imitation	
Class I - Rigonda-S	Stereo LW MW 2 SW 1 USW 4 -speed 4 -speakers			Wood Lacquered	
Highest Class - Estonia 3	LW MW 5 SW 25m. USW 4 speakers 4-speed			Lacquered Wood	5

4

I.K. Characteristics of Several Types of Soviet Radios

Number and Type of Bands	Number of Transistors (if any)	Sensitivity	Type of Cabinet	Weight	Real Price	Service Charge*	Retail Price
Seven: LW 150-410 KC. MW 520-1600 KD. SW 75-52, m 50 m 41 m 31 meters 25 meters** **model for internal sale. Export model goes down to 13m.	10	LW - 2MV/M MW - 1MV/M SW - 200 microvolts	Black and Yellow Plastic	6kg?	65r.	9r.75k	74r.75r.
Two: LW MW	7	LW - 3MV/M MW - 1.5 MV/M			27r.	4r.	31r. (108)
LW MW	8	LW - 3MV/M MW - 1.5 MV/M			24r.	3r60k.	27r.60k.
LW MW					75r.	11r.25k	86r.25k.
LW MW			Wood and plastic. Plastic top.		42r.	6r.30k.	48r.30k.
3-speed record player LW MW SW			Wooden		50r.	7r.50k.	57r.50k.
2 speakers 3-speed LW MW			Laquered wood or plastic imit.wood		85r.	12r.75k.	97r.75k.
1 USW Stereo LW MW			Wood Laquer		Table: 190r.	28r.50k.	218r.50k.
2 SW 1 USW 4 -speed 4 -speakers					Floor: 200r.	30r.	230r.
LW MW SW 25m. USW 4 speakers 4-speed	5		Laquered Wood		210r.	31r.50k	241r.50k.

B



II.A. The Leningrad Committee on Radio and Television\*\*

Editorial Boards:

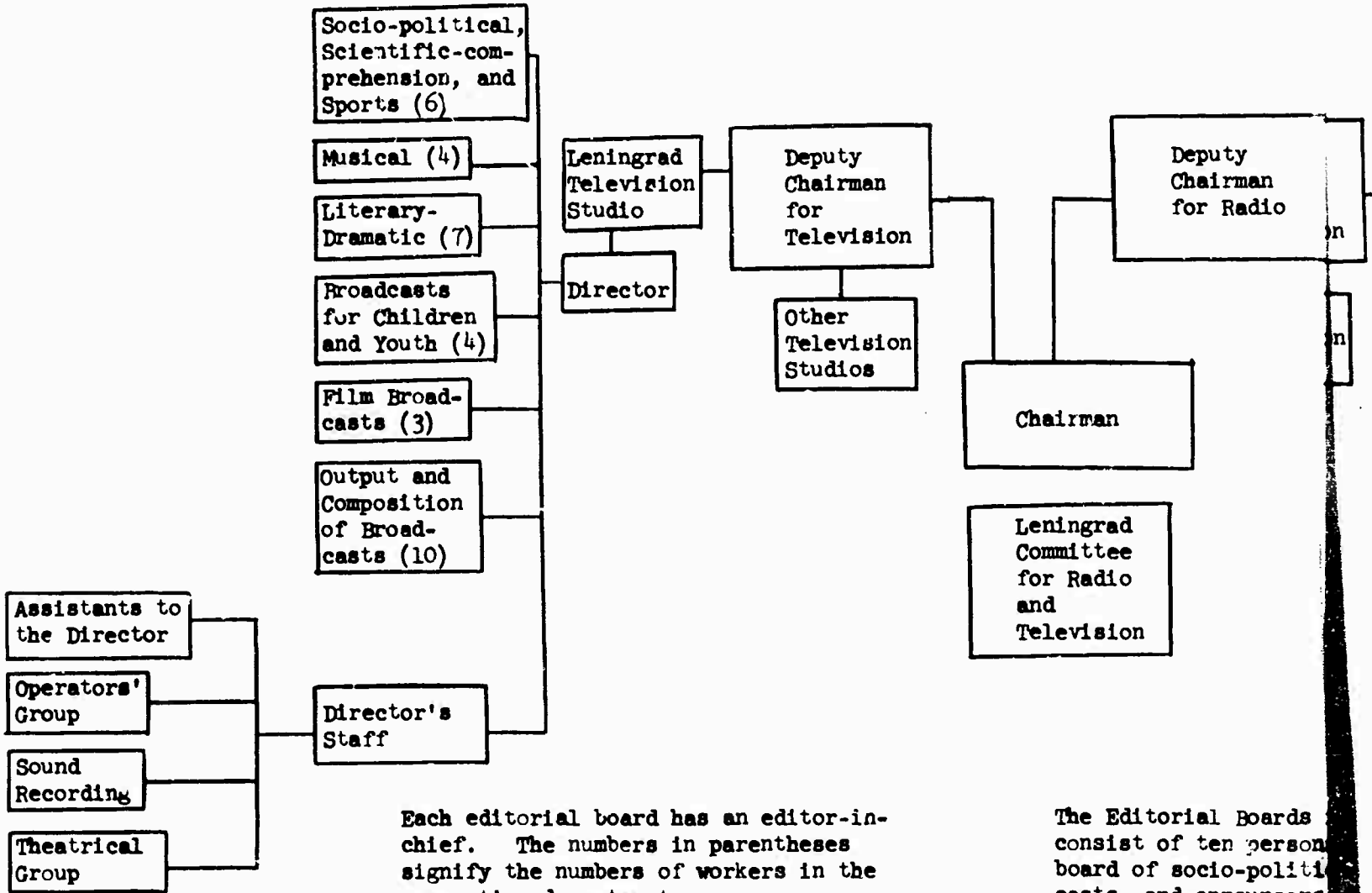

Each editorial board has an editor-in-chief. The numbers in parentheses signify the numbers of workers in the respective departments.

\*\*From accumulated Source materials.

The Editorial Boards consist of ten person board of socio-political casts, and announcers gorod, Ryazin, Kalini importance. This six programming per day t

Main Editorial Boards:

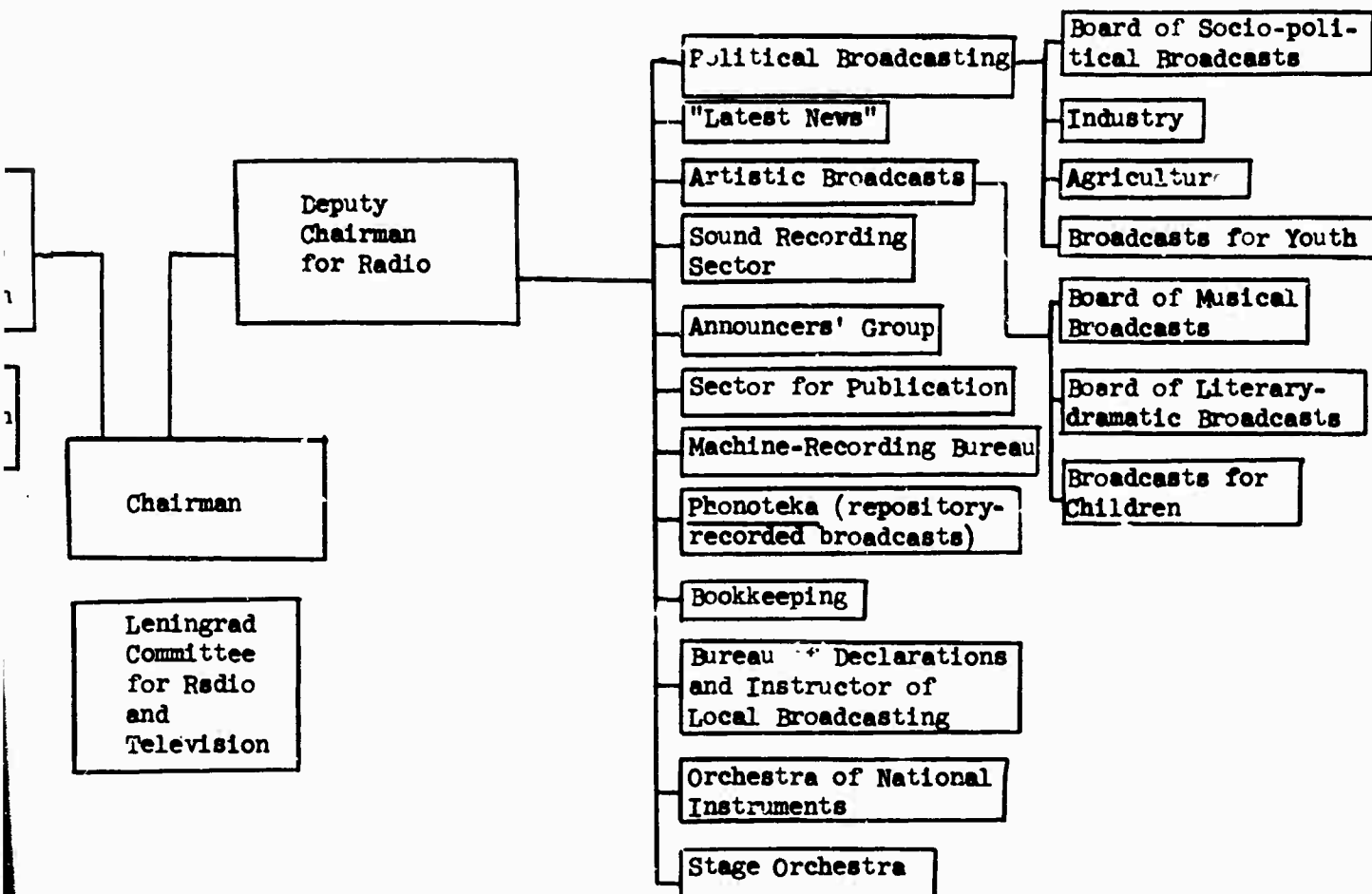

The Editorial Boards for the other administrative areas usually consist of ten persons: Editor-in-Chief, workers of the editorial board of socio-political broadcasts and musical-artistic broadcasts, and announcers. Such is the administration of Pskov, Novgorod, Ryazin, Kalinin, and other cities of comparable size and importance. This size group is responsible for considerably less programming per day than is the Leningrad Committee.

II.B. The Moscow Television Studio: Structure of Administrative Apparatus\*\*

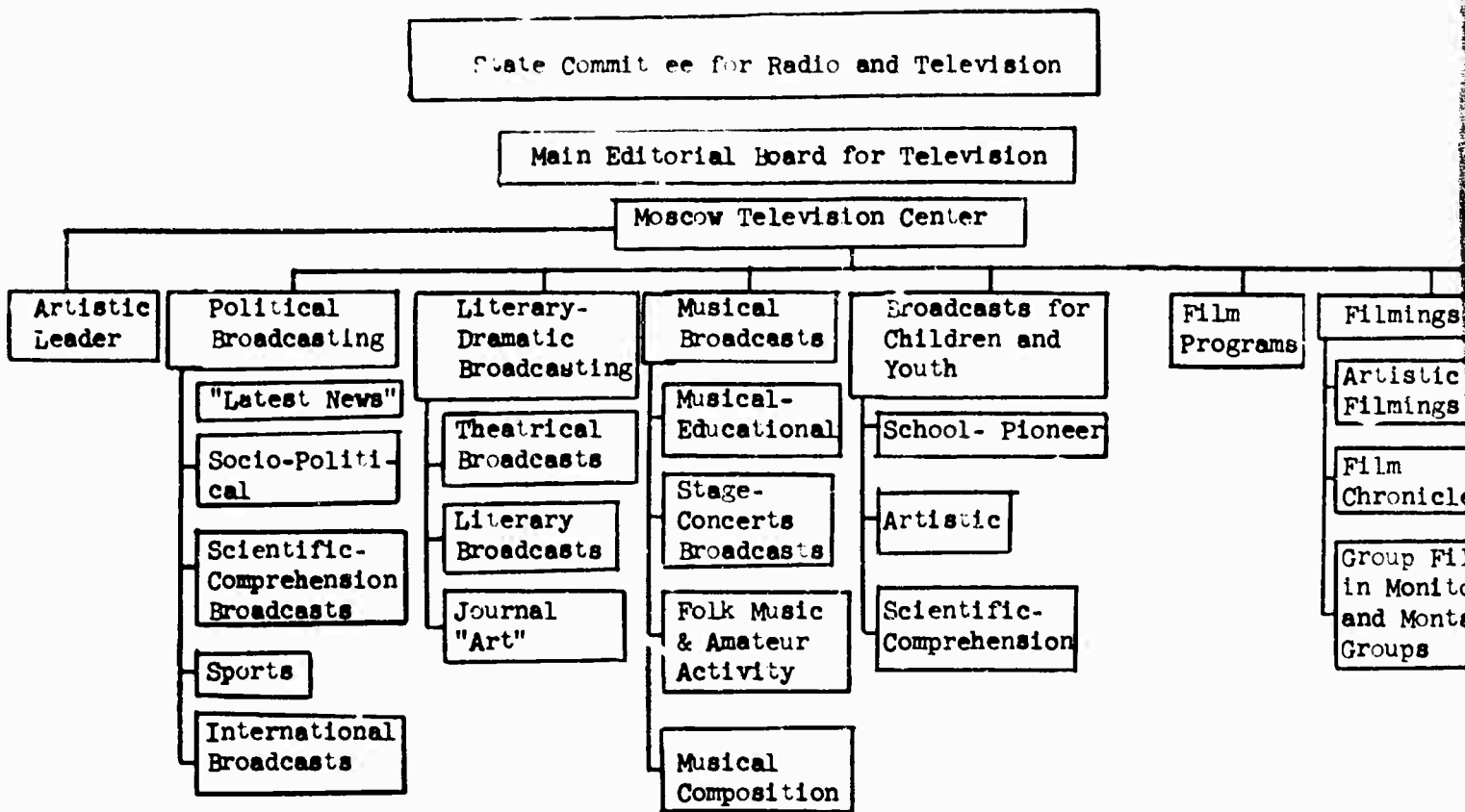

In the Main Editorial Boards are the following Personnel:  
 Editor-in-Chief, Senior Editors, Editors; Main, Senior and  
 and Ordinary Directors, assistants and aides to Directors:  
 Controllers of Broadcasts, Announcers: film Operators:  
 Engineers of sound recording: Sound Directors: Artistic-  
 producers, artistic-scriptwriters, artistic photographers,  
 other special production cells.

\*\*From accumulated source materials.

television

television

er

casts for  
ren and

- Pioneer

ic

ific-  
ension

Film  
Programs

Filmings

Artistic  
Filmings

Film  
Chronicles

Group Filming  
in Monitor  
and Montage  
Groups

Editing of  
Programs  
and  
Publications

Letters

Information

Production-  
Artistic Groups  
and Cells

Groups of Ar-  
tistic Compo-  
sition

Groups of  
Television  
Operators

Groups of  
Sound  
Composition

Theatrical  
Part

Machine-  
Decoration

Furniture  
Props

Model and  
artificial  
props

Decorative-  
drapes

Lighting

Make-up

Costumes

Others

15

**BLANK PAGE**

III. A. Broadcast Content and Frequency, Before and After  
October 15, 1962

Topic	Before		After	
	Number of Times	Minutes	Number of Times	Minutes
<u>First Program</u> <u>(All-Union)</u>				
News	78	1,020	111	760
Press review	20	305	32	455
Commentators' talks	16	185	20	215
Your letters	?	15	--	---
Answers to questions	--	--	1	15
Talks (sociological, economic, political)	6	90	--	--
Impressions and thoughts	--	--	6	90
From the Socialist countries	6	180	6	180
Writers at the Microphone	4	25	1	15
Komsomolia	2	45	--	--
Youth	--	--	1	25
		<hr/>		<hr/>
Total		1,865		1,755

## III. A. (continued)

	Before		After	
	Number of Times	Minutes	Number of Times	Minutes
<u>Second Program (RFSR)</u>				
News	22	300	21	280
Press Rev	--	---	27	345
Talks on inter- national topics	3	40	8	120
From socialist countries	7	210	5	150
"Youth"	--	---	7	630
Listeners' Letters	--	---	7	70
		<hr/>		<hr/>
total		550		1,595

## 111. A. (continued)

	Before		After	
	Number of Times	Minutes	Number of Times	Minutes
<u>Fourth Program</u>				
News	27	375	144	1,260
Press review	6	60	34	445
News for Arctic & Antarctic	--	--	4	120
Commentaries, talks	1	30	21	275
Your letters	2	45	--	--
Impressions, thoughts and plans	--	--	3	45
Answers to your questions	--	--	1	20
Writers at the microphone	--	--	2	40
		510 minutes		2,205 minutes
Total				

These tables were prepared as a result of a monitoring period of eight days, beginning on October 15, 1962. These time periods, may not be the same today, but may be considered representative of the present schedule, and particularly of the present schedule contrasted with the pre-October 15, 1962 schedule.

From: "An Eight-Day Analysis of New Programmes on the Soviet Radio," Leonid Kubik, Radio Liberty, October 25, 1962.



III. B. Wave-length Table of Pre-October 15, 1962 Schedule

WAVELENGTH TABLE  
OF TRANSMISSIONS OF THE 1st AND 2nd PROGRAMS BY CENTRAL BROADCASTING

P R O G R A M	Wavelengths in meters (Short waves are given in bands)	Frequency in Kilocycles	HOURS ON THE AIR (MOSCOW TIME)				
			Daily (Except Sat- urdays and Sundays)		Saturdays (Sat.) and Sundays (Sun.)		
			FROM	TO	SAT. SUN.	FROM	TO
	1,987		0600	0100	Sat. Sun	0600	0200
	1,734		0600	0100	"	0600	0200
	1,271		0600	0100	"	0600	0200
	1,141		0600	0100	"	0600	0100
	750		1545	2405	"	1500	2405
	74		0730	1800	"	0730	1800
	74		1900	0100	"	1900	0100
F	51		0600	0845	"	0600	0845
I	51		1730	0100	"	1730	0100
R	49		0600	0930	"	0600	0930
S	49		1700	2405	"	1700	2405
T	41		0600	0820	"	0600	0820
	41		1000	0100	"	1000	0200
	31		0800	2300	"	0800	2300
	25		0800	1920	"	0600	1920
	Ultra short wave FM		0800	1315	Sat.	0600	1315
	4.3 (For Moscow and		1400	1830	"	1400	1830
	the oblast)		1900	0100	"	1900	0100
			Note: Off the air from		Sun.	0600	1800
			1500 - 1545		"	1830	0200
	1500	200	Ex- 1000	1520	Sun.	0845	1530
	882.4	340	cept. 1920	0100	Sat.-Sun.	1920	0100
	820	365	Sun. 1920	2405	"	1920	2405
	779	385	" 1600	0100	"	1600	0100
	574.4	548	" 1000	1600	Sun.	0845	1800
	433.5	692.8	" 1000	1600	"	0845	2405
S	433.5	692.8	" 1830	2405	"	0845	2405
E	107.1	737	" 1900	2405	"	0845	0100
C	370.8	809	" 1000	1700	Sat.-Sun.	1920	0100
O	370.8	809	" 1900	0100	"	1500	1830
N	362.8	827	" 1920	0100	"	1530	2300
D	309	971	" 1500	1830	"	1430	2405
	49		" 1530	2300	Sun.	0845	1800
	41		" 1430	2405	"	0845	1500
	31		" 1000	1800	Sat.	1000	1600
	25		" 1000	1500	"	1800	0100
	Ultra Short wave FM 4.52		" 1000	1800	Sun.	0845	1130
	(For Moscow and the oblast)		" 1900	0100	"	1830	0100

Source: Kaftanov, S.V., et. al., eds., Radio i televizheniye, USSR.  
Moscow, 1961, p. 35.

(115)

III. C. Quantity of Radiobroadcasting, Union Republics, 1959

Republic	Number of Program Channels	Total Daily Broadcast Time	Language of Broadcasts
<b>RSFSR:</b> Total information not given. Broadcasts generally in Russian, primarily from Central Broadcasting in Moscow. Example: Leningrad broadcasts all basic Central Broadcasting programs, plus 10.5 local hours per day. Krasnoyarsk broadcasts 8 local hours, Magadan 7, Omsk 6, Trkutsk 9½, and so on.			
Ukrainian SSR	2	1st-9 hrs 2nd-7 hrs	Ukrainian Russian Bulgarian
Byelorussian SSR	2	18 hrs	Byelorussian Russian
Latvian	2	17 hrs	Latvian Russian
Lithuanian SSR	2 basic, 2 extra*	18 hrs, 25 min	Lithuanian Russian Polish
Estonian SSR	2	17 hrs	Estonian Russian
Moldavian SSR	2	12 hrs	Moldavian Russian Gaguaz
Azerbaijani SSR	1	15.8 hrs	Azerbaijani Armenian Russian
Armenian SSR	2	20 hrs, 30 min	Armenian Russian Azerbaijani Kurd Arabic
Georgian SSR	1	17.5 hrs	Georgian Russian Armenian Azerbaijani

## III. C. (continued)

Republic	Number of Program Channels	Total Daily Broad- cast Time	Language of Broadcasts
Kazakh SSR	2	17 hrs, 25 min	Kazakh, Russian Urgur, Chechen German
Uzbek SSR	2	15 hrs, 30 min	Uzbek, Russian Tadzhik, English Uygur, arsi
Kirghiz SSR	1	8 hrs, 30 min	Kirghiz, Russian
Tadzhik SSR	2	10 hrs	Tadzhik, Russian
Turkmen SSR	1	8 hrs, 30 min	Turkmen, Russian

---

Source: Compiled from Kaftanov, op. cit., pp. 109-126.

III. D. The Overall Volume of Television Broadcasting in the USSR  
(thousand hours)

Year	All TV Studios	Central TV Studio	Rebroadcast Stations
1950	1.3	0.8	
1951	1.5	1.0	
1952	2.1	1.1	
1953	2.8	1.2	
1954	3.4	1.4	
1955	5.6	1.6	1.7
1956	11.0	1.9	1.7
1957	20.7	2.5	4.5
1958	40.2	3.0	8.8
1959	59.8	3.0	16.5
1960 plan	89.4	3.2	28.4
1965 plan	186.2	9.0	140.5

---

Source: Kaftanov, S.V., op. cit., p. 135.

III. E. CST Program Schedule by Category, Number of Broadcasts, and Broadcast Hours (January through June, 1960)

Category	First Program		Second Program		Totals	
	Broadcasts	Hours	Broadcasts	Hours	Broadcasts	Hours
Children	141	110:10	39	19:50	180	130:00
Concerts	99	83:50	67	46:20	166	130:10
Culture	87	56:20	63	45:25	150	101:45
Education:	66	40:25	27	13:30	93	53:55
TV University	(41)	(24:45)	(3)	(1:30)		
English lessons	(25)	(15:40)	(24)	(12:00)		
Films:	123	145:20	109	128:40	232	274:00
Domestic	(83)	(94:00)	(81)	(85:55)		
Foreign	(40)	(51:20)	(28)	(42:45)		
News Reviews	377	63:25	26	8:25	403	71:50
Late News	(357)	(59:30)	--	----		
Reviews	(20)	(3:55)	(26)	(8:25)		
Plays	77	103:05	36	52:50	113	155:55
Science	21	:00	22	7:35	43	16:35
Special Events	83	62:40	20	21:30	103	84:10
Sports	61	54:10	65	94:10	126	148:20
Young Adult	38	35:55	6	6:05	44	42:00
Miscel.	190	85:25	172	58:10	362	143:35
Originations from other studios	9	15:00	--	----	9	15:00
On air, no program title given	8	10:30	--	----	8	10:30
<b>Total hours</b>		<b>875:15</b>		<b>502:30</b>		<b>1,377:45</b>

Source: Tuber, Richard, "A Survey of Programming on the Central Studios of Television, Moscow, USSR, January-June, 1960." Journal of Broadcasting, Fall, 1960, pp. 315-325.

III. F. Program Schedule of Radio and Television Programs for  
March 23, 1964 (Monday) in Moscow

Radio

First Program (All-Union)

- 12:20 Vocal cycle "Ballad of War and Peace"  
2:00 P.M. Variety Miniatures  
3:30 P.M. "The Forty-fifth Spring," a program on the first forty-  
five years of the Bashkir Autonomous Republic  
4:15 P.M. For Children: Stories  
5:30 P.M. A Short Lesson on Musical Knowledge  
6:30 P.M. A Concert of Requests  
7:00 P.M. Candidates Nominated for Competition for Lenin Prizes:  
Poetess I. Archipova  
7:30 P.M. Verses of Bashkir Poets  
8:10 P.M. Continuation of Concert of I. Archipova  
9:20 P.M. "In the Free Hour" Radio collection  
10:30 P.M. Evening Program of the Radiostation "Yunost" (Youth)

Second Program (RSFSR)

- 11:00 A.M. Radio-University of Culture: "N. Ostrovskii"  
12:00 P.M. "With a Smile and Without a Smile" Lyrical concert.  
1:00 P.M. "Daughter of a Russian Actor" Vodeville Grigorievna  
3:00 P.M. For Children: "Old Man Khottabich"  
4:00 P.M. "Steps of the Seven-Year Plan" Program for Workers  
of Industry  
5:45 P.M. "The Twentieth Century and Myths of Antiquity" Debate  
6:00 P.M. Program of the Radio-Station "Yunost" (Youth)  
7:00 P.M. New Songs of Soviet Authors  
7:35 P.M. Rural Library  
8:10 P.M. J. London, "Thousand Dozen," a story  
9:30 P.M. Broadcast of a Concert from Prague

III. F. (continued)

Television

Program I. All-Union

11:30 A.M. "Street of the Younger Brother," Feature Film  
4:55 P.M. Program broadcast  
5:00 P.M. "Club of Joyful Humanists"  
5:30 P.M. Spring Day  
6:00 P.M. School of Agronomists's Knowledge  
6:50 P.M. TV News  
7:00 P.M. Concert of National Artists RSK and I. Archipova  
9:00 P.M. "Goals, Spectacles, Seconds," Sports of the Week  
9:30 P.M. TV News  
10:30 P.M. Master of Arts

Program II. (Moscow Area)

6:00 P.M. "In the World of Science and Technology"  
6:40 P.M. "Golden Yourta" (\*Yourta is a nomad tent)  
8:00 P.M. Moscow News  
8:20 P.M. "World Turned Toward the Sun," New film survey.  
8:40 P.M. "On Construction Sites of Moscow"  
9:00 P.M. "News of Musical Life"

---

Source: Izvestia, Sunday, March 22, 1964, p. 4.

IV. A. Number of Persons Per Wired Set 1961

Republic	Approximate 1961 Population (millions)	Persons per set
USSR	215.	6.7
RSFSR	120.	6.3
Ukrainian SSR	42.	5.5
Byelorussian SSR	8.5	6.4
Moldavian SSR	2.9	6.6
Latvian SSR	2.4	12.8
Lithuanian SSR	2.9	17.1
Estonian SSR	1.4	16.8
Georgian S. R	4.4	10.2
Azerbaijanzhanian SSR	3.9	11.5
Armenian S. R	1.9	13.9
Kazakh S. R	9.0	8.9
Uzbek SSR	8.9	9.8
Kirghiz SSR	2.2	10.3
Tadzhik SSR	2.1	13.3
Turkmen SSR	1.6	10.0

(Based on data from Table I. A.)



IV. B. Number of Persons Per Wave Set, 1962

Republic	Population (millions*)	Persons Per Wave Set
RSFSR	121.0	7.1
Ukrainian SSR	43.0	13.1
Byelorussian SSR	8.5	25.0
Moldavian SSR	3.0	17.1
Latvian SSR	2.5	6.0
Lithuanian SSR	3.0	11.1
Estonian SSR	1.5	6.6
Georgian SSR	4.5	20.7
Azerbaijani SSR	4.0	16.0
Armenian SSR	2.0	12.1
Kazakh SSR	10.0	19.5
Uzbek SSR	9.0	18.0
Kirghiz SSR	2.3	23.0
Tadzhik SSR	2.2	29.7
Turkmenian SSR	1.7	20.2
USSR	218.2	9.3

\* Estimates based on 1959 census returns.

(Based on data from Table I. A.)

DOCUMENT CONTROL DATA - R&D

(Security classification of title, body of abstract and indexing annotation must be entered when the overall report is classified)

1. ORIGINATING ACTIVITY (Corporate author) Massachusetts Inst. of Tech., Cambridge. Center for International Studies		2a. REPORT SECURITY CLASSIFICATION Unclassified	
		2b. GROUP	
3. REPORT TITLE RADIO AND TELEVISION IN THE SOVIET UNION			
4. DESCRIPTIVE NOTES (Type of report and inclusive dates) <del>Scientific</del> <b>Scientific</b> <del>Interim</del> <b>Interim</b>			
5. AUTHOR(S) (Last name, first name, initial) Durham, F. Gayle (Married, name is now Hollander)			
6. REPORT DATE June 1965	7a. TOTAL NO. OF PAGES 122	7b. NO. OF REFS 85	
8a. CONTRACT OR GRANT NO. AF 49(638)-1237	9a. ORIGINATOR'S REPORT NUMBER(S) C/64-10		
8b. PROJECT NO. ARPA #920F-9717 c 61445014 d 681313	9b. OTHER REPORT NO(S), (Any other numbers that may be assigned) <b>AFOSR 67-0955</b>		
10. AVAILABILITY/LIMITATION NOTICES Distribution of this document is unlimited [Redacted]			
11. SUPPLEMENTARY NOTES Tech Other		12. SECURITY CLASSIFICATION Air Force Office of Scientific Research (SAS)	

13. ABSTRACT  
 This paper can be divided into six major sections. The first one deals with the broadcasting network within the Soviet Union; Here the author delves into radiobroadcasting, broadcasting stations, television broadcasting, number of television stations, and radio and television in rural localities. The next section covers production and repair of radio and television sets and also covers future radio and television sets and subscription fees. . . The third section treats the Administration of Soviet Radio and Television-the structural apparatus of the Broadcasting Administration and its functions. In the fourth chapter the author discusses programs and hours of radio and television broadcasting. Here she also goes into educational TV in the USSR, radio and television in Dnepropetrovsk, Ukrainian SSR, and recording of broadcasts. The fifth section pertains to Intervision which is the central network connecting the television broadcasting systems of the major socialist countries. In the final section the author studies the Soviet audience-the size of the audience, the nature of the audience, and audience feedback and listening behavior.  
 (U)

KEY WORDS	LINK A		LINK B		LINK C	
	ROLE	WT	ROLE	WT	ROLE	WT
Subscription fees State Committee on Radio and Television <u>Intervision'</u> Wired network Wave receiver Radio-uzel (single diffusion exchange) Multi-programming FM, Short wave, medium wave broadcasting Ministry of Communications State House of Radiobroadcasting and Sound Recording Audience feedback Listening Behavior						

**INSTRUCTIONS**

1. **ORIGINATING ACTIVITY:** Enter the name and address of the contractor, subcontractor, grantee, Department of Defense activity or other organization (corporate author) issuing the report.

2a. **REPORT SECURITY CLASSIFICATION:** Enter the overall security classification of the report. Indicate whether "Restricted Data" is included. Marking is to be in accordance with appropriate security regulations.

2b. **GROUP:** Automatic downgrading is specified in DoD Directive 5200.10 and Armed Forces Industrial Manual. Enter the group number. Also, when applicable, show that optional markings have been used for Group 3 and Group 4 as authorized.

3. **REPORT TITLE:** Enter the complete report title in all capital letters. Titles in all cases should be unclassified. If a meaningful title cannot be selected without classification, show title classification in all capitals in parentheses immediately following the title.

4. **DESCRIPTIVE NOTES:** If appropriate, enter the type of report, e.g., interim, progress, summary, annual, or final. Give the inclusive dates when a specific reporting period is covered.

5. **AUTHOR(S):** Enter the name(s) of author(s) as shown on or in the report. Enter last name, first name, middle initial. If military, show rank and branch of service. The name of the principal author is an absolute minimum requirement.

6. **REPORT DATE:** Enter the date of the report as day, month, year; or month, year. If more than one date appears on the report, use date of publication.

7a. **TOTAL NUMBER OF PAGES:** The total page count should follow normal pagination procedure, i.e., enter the number of pages containing information.

7b. **NUMBER OF REFERENCES:** Enter the total number of references cited in the report.

8a. **CONTRACT OR GRANT NUMBER:** If appropriate, enter the applicable number of the contract or grant under which the report was written.

8b, 8c, & 8d. **PROJECT NUMBER:** Enter the appropriate identification, such as project number, subproject number, system numbers, task number, etc.

9a. **ORIGINATOR'S REPORT NUMBER(S):** Enter the official report number by which the document will be identified and controlled by the originating activity. This number must be unique to this report.

9b. **OTHER REPORT NUMBER(S):** If the report has been assigned any other report numbers (either by the originator or by the sponsor), also enter this number(s).

10. **AVAILABILITY, LIMITATION NOTICES:** Enter any limitations on further dissemination of the report, other than those

imposed by security classification, using standard statements such as:

- (1) "Qualified requesters may obtain copies of this report from DDC."
- (2) "Foreign announcement and dissemination of this report by DDC is not authorized."
- (3) "U. S. Government agencies may obtain copies of this report directly from DDC. Other qualified DDC users shall request through \_\_\_\_\_."
- (4) "U. S. military agencies may obtain copies of this report directly from DDC. Other qualified users shall request through \_\_\_\_\_."
- (5) "All distribution of this report is controlled. Qualified DDC users shall request through \_\_\_\_\_."

If the report has been furnished to the Office of Technical Services, Department of Commerce, for sale to the public, indicate this fact and enter the price, if known.

11. **SUPPLEMENTARY NOTES:** Use for additional explanatory notes.

12. **SPONSORING MILITARY ACTIVITY:** Enter the name of the departmental project office or laboratory sponsoring (paying for) the research and development. Include address.

13. **ABSTRACT:** Enter an abstract giving a brief and factual summary of the document indicative of the report, even though it may also appear elsewhere in the body of the technical report. If additional space is required, a continuation sheet shall be attached.

It is highly desirable that the abstract of classified report be unclassified. Each paragraph of the abstract shall end with an indication of the military security classification of the information in the paragraph, represented as (TS), (S), (C), or (U).

There is no limitation on the length of the abstract. However, the suggested length is from 150 to 225 words.

14. **KEY WORDS:** Key words are technically meaningful terms or short phrases that characterize a report and may be used as index entries for cataloging the report. Key words must be selected so that no security classification is required. Identifiers, such as equipment model designation, trade name, military project code name, geographic location, may be used as key words but will be followed by an indication of technical context. The assignment of links, rules, and weights is optional.