

Intel(R) Pentium(R) III and FC-PGA Celeron(tm) Processor / 815E Chipset Universal Socket 370 Platform Customer Reference Board Schematics

Revision 1.05 - Fab C

| TITLE | PAGE |
|---------------------------------|-------|
| COVER SHEET | 1 |
| BLOCK DIAGRAM | 2 |
| PGA370 PART 1 & 2 | 3,4 |
| AGTL TERMINATION | 5 |
| CLOCK GENERATOR | 6 |
| GMCH PART 1 & 2 | 7,8 |
| DIMM 1 & 2 | 9 |
| DIMM 3 | 10 |
| AGP | 11 |
| ICH PART 1 & 2 | 12,13 |
| PCI 1 & 2 | 14 |
| PCI 3 | 15 |
| VIDEO BUS & CONNECTOR | 16 |
| FWH & UDMA100 IDE 1-2 | 17 |
| USB 0-3 | 18 |
| AC97 CODEC | 19 |
| AUDIO I/O | 20 |
| LPC I/O CONTROLLER & FDCL | 21 |
| WOR, WOL & 2S1P | 22 |
| KB, MS, GAME & IR | 23 |
| FRONT PANEL & CNR | 24 |
| ATX POWER & H/W MONITOR | 25 |
| VREGS: VDDQ, VCC1_8, AND VTT | 26 |
| VREGS: VCCVID, V1_8SB | 27 |
| VREGS: DUALS, 3.3SB, 2.5, VCMOS | 28 |
| SYSTEM CONFIGURATION | 29 |
| PU/PDR & UNUSED GATES | 30 |
| DECOUPLING CAPACITORS | 31 |
| INTERNAL DEBUG HEADERS | 32 |
| THERMTRIP | 33 |

Information in this document is provided in connection with Intel® products. No license, express or implied, by estoppel or otherwise, to any intellectual property rights is granted by this document. Except as provided in Intel's Terms and Conditions of Sale for such products, Intel assumes no liability whatsoever, and Intel disclaims any express or implied warranty, relating to sale and/or use of Intel products including liability or warranties relating to fitness for a particular purpose, merchantability, or infringement of any patent, copyright or other intellectual property right. Intel products are not intended for use in medical, life saving, or life sustaining applications.

Intel may make changes to specifications and product descriptions at any time, without notice. Designers must not rely on the absence or characteristics of any features or instructions marked "reserved" or "undefined." Intel reserves these for future definition and shall have no responsibility whatsoever for conflicts or incompatibilities arising from future changes to them.

The Intel® 815E chipset may contain design defects or errors known as errata which may cause the product to deviate from published specifications. Current characterized errata are available on request.

Contact your local Intel sales office or your distributor to obtain the latest specifications and before placing your product order.

I2C is a two-wire communications bus/protocol developed by Philips. SMBus is a subset of the I2C bus/protocol and was developed by Intel. Implementations of the I2C bus/protocol may require licenses from various entities, including Philips Electronics N.V. and North American Philips Corporation.

Alert on LAN is a result of the Intel-IBM Advanced Manageability Alliance and a trademark of IBM.

Copies of documents which have an ordering number and are referenced in this document, or other Intel literature, may be obtained by calling 1-800-548-4725 or by visiting Intel's website at <http://www.intel.com>.

Intel®, Pentium®, Pentium® III, Celeron™, are trademarks or registered trademarks of Intel Corporation or its subsidiaries in the United States and other countries.

*Other brands and names may be claimed as the property of others.

Copyright© 2001, Intel Corporation

****PLEASE NOTE THESE SCHEMATICS ARE SUBJECT TO CHANGE**

| | |
|--|---|
| Document: Intel(R) 815E Chipset Universal Socket 370 CRB | |
| Page Name: Title Page | |
| Last Revised: | Page: Monday, April 30, 2001 Doc: Monday, April 30, 2001 |
|  Platform Applications Engineering 1900 Prairie City Road Folsom, CA 95630 | Revision: 1.05 |
| | Page No: 1 of 33 |

BLOCK DIAGRAM

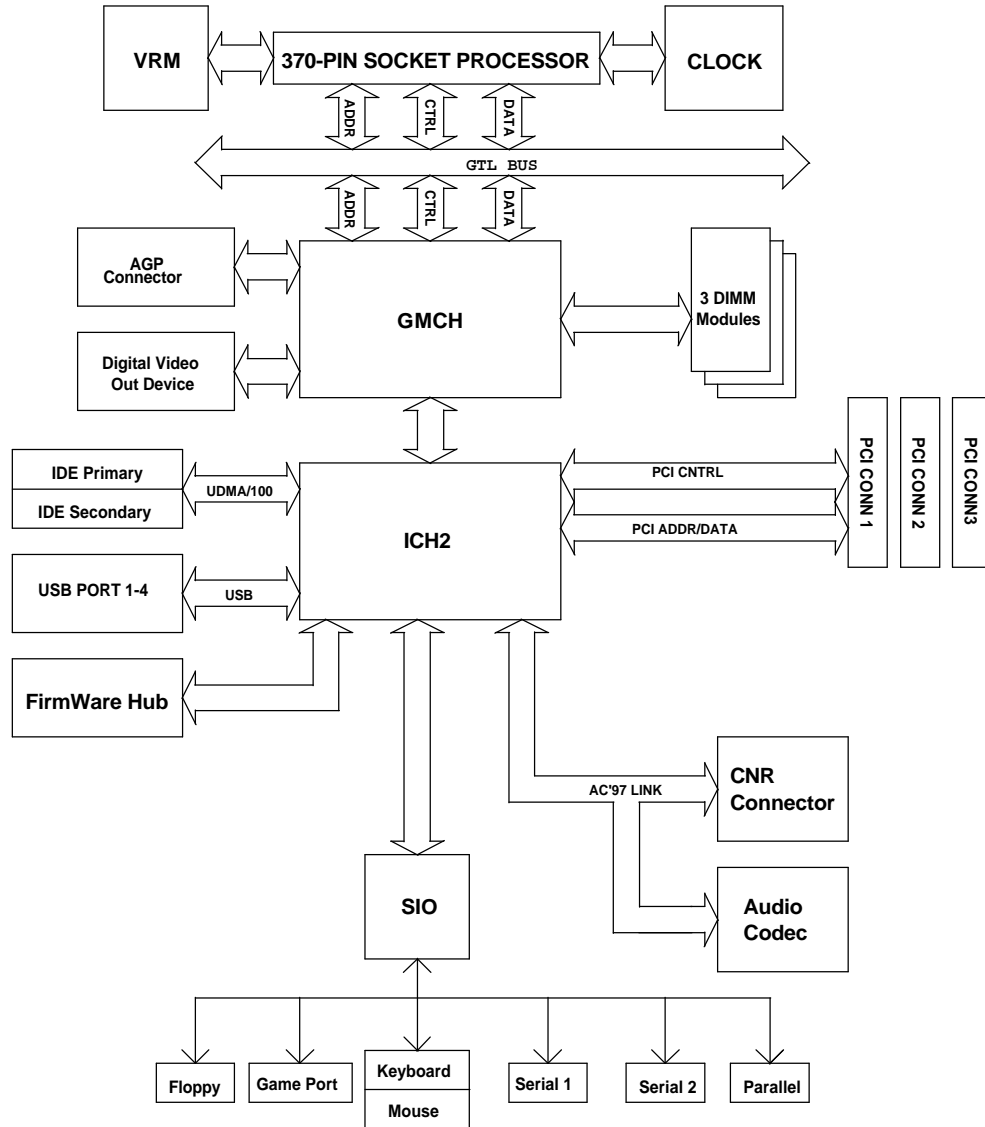

| | |
|--|---|
| Document: Intel(R) 815E Chipset Universal Socket 370 CRB | |
| Page Name: Block Diagram | |
| Last Revised: | Page: Monday, April 30, 2001 Doc: Monday, April 30, 2001 |
|  Platform Applications Engineering 1900 Prairie City Road Folsom, CA 95630 | Revision: 1.05 |
| | Page No: 2 of 33 |

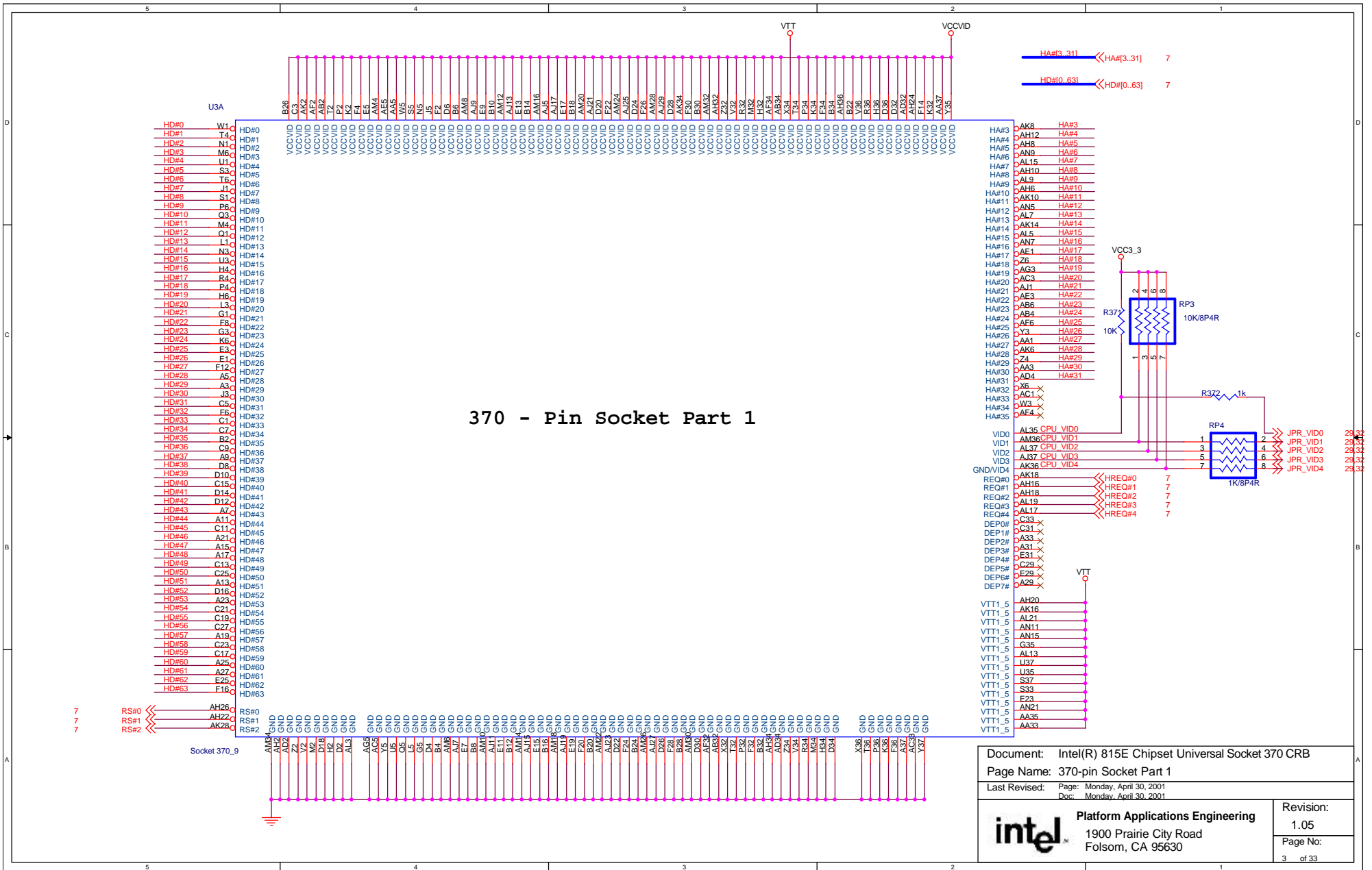

370 - Pin Socket Part 1

Document: Intel(R) 815E Chipset Universal Socket 370 CRB
 Page Name: 370-pin Socket Part 1
 Last Revised: Page: Monday, April 30, 2001
 Doc: Monday, April 30, 2001

intel Platform Applications Engineering
 1900 Prairie City Road
 Folsom, CA 95630

Revision:
 1.05
 Page No:
 3 of 33

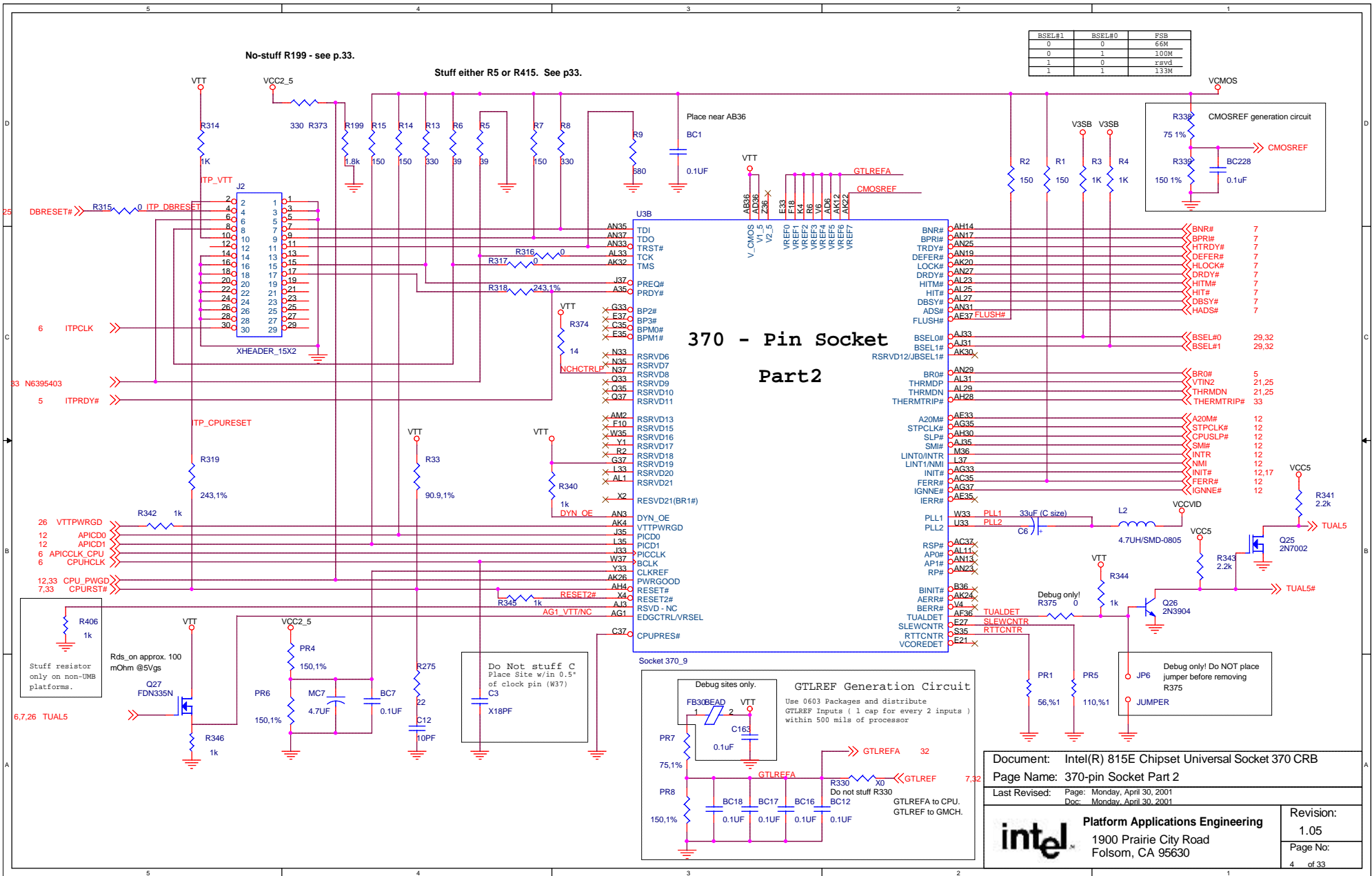

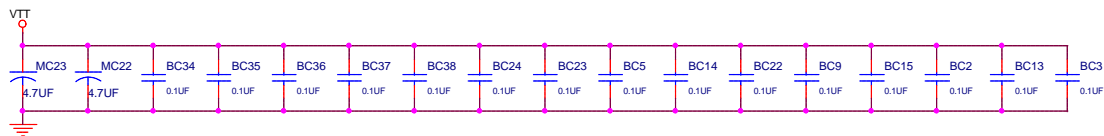

VTT
 Do not populate in assembly - debug sites only.
 Debug cap sites - place near processor

C164
 820uF

VTT Decoupling

| | |
|--|---|
| Document: Intel(R) 815E Chipset Universal Socket 370 CRB | |
| Page Name: VTT Decoupling | |
| Last Revised: | Page: Monday, April 30, 2001 Doc: Monday, April 30, 2001 |
| Platform Applications Engineering 1900 Prairie City Road Folsom, CA 95630 | Revision: 1.05 |
| | Page No: 5 of 33 |

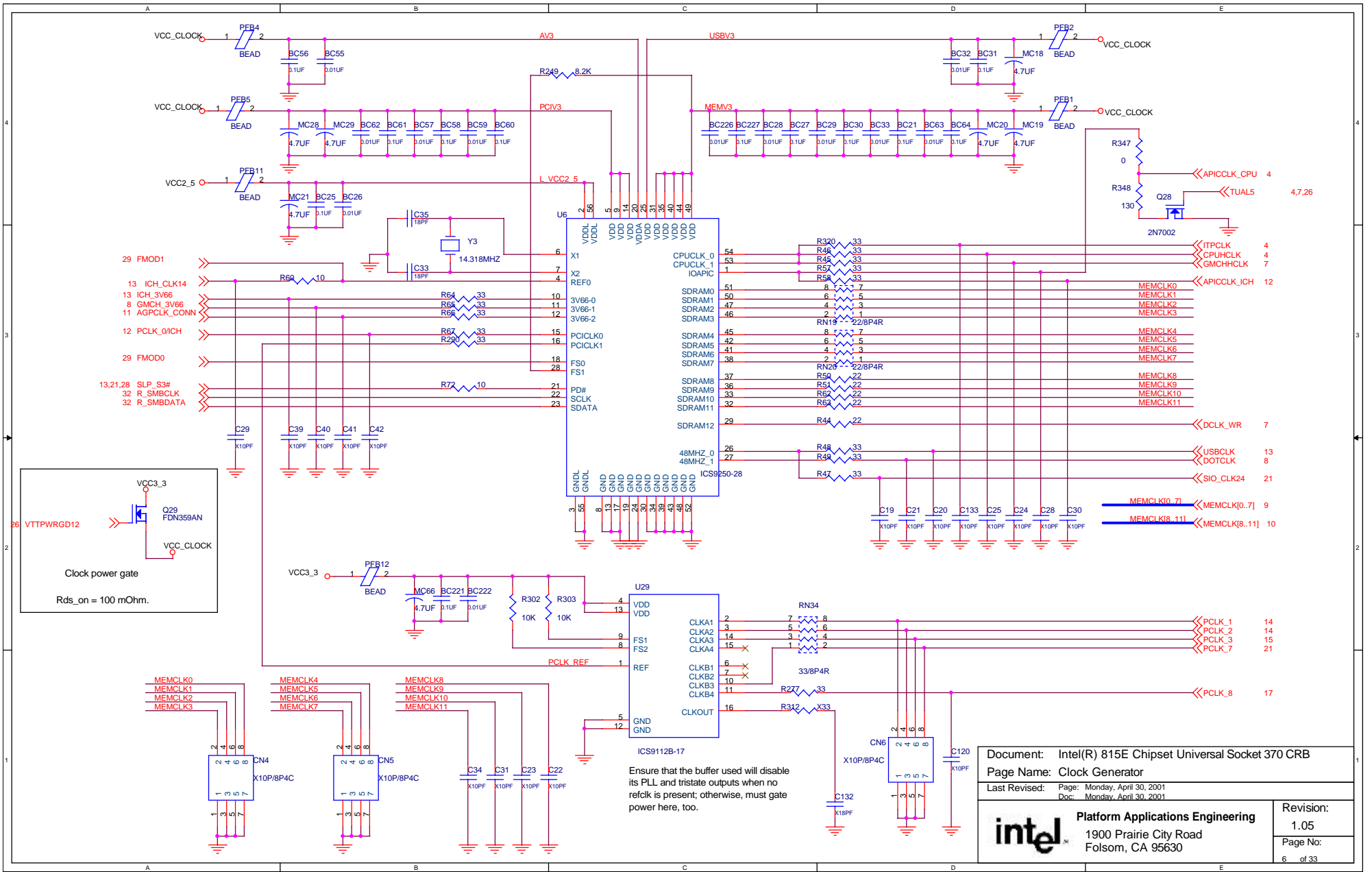

VCC3_3
 Q29 FDN359AN
 VCC_CLOCK
 Clock power gate
 Rds_on = 100 mOhm.

U29 ICS912B-17
 Ensure that the buffer used will disable its PLL and tristate outputs when no refclk is present; otherwise, must gate power here, too.

| | |
|---|-----------------------------|
| Document: Intel(R) 815E Chipset Universal Socket 370 CRB | |
| Page Name: Clock Generator | |
| Last Revised: Page: Monday, April 30, 2001 | Doc: Monday, April 30, 2001 |
| Platform Applications Engineering 1900 Prairie City Road Folsom, CA 95630 | Revision: 1.05 |
| | Page No: 6 of 33 |

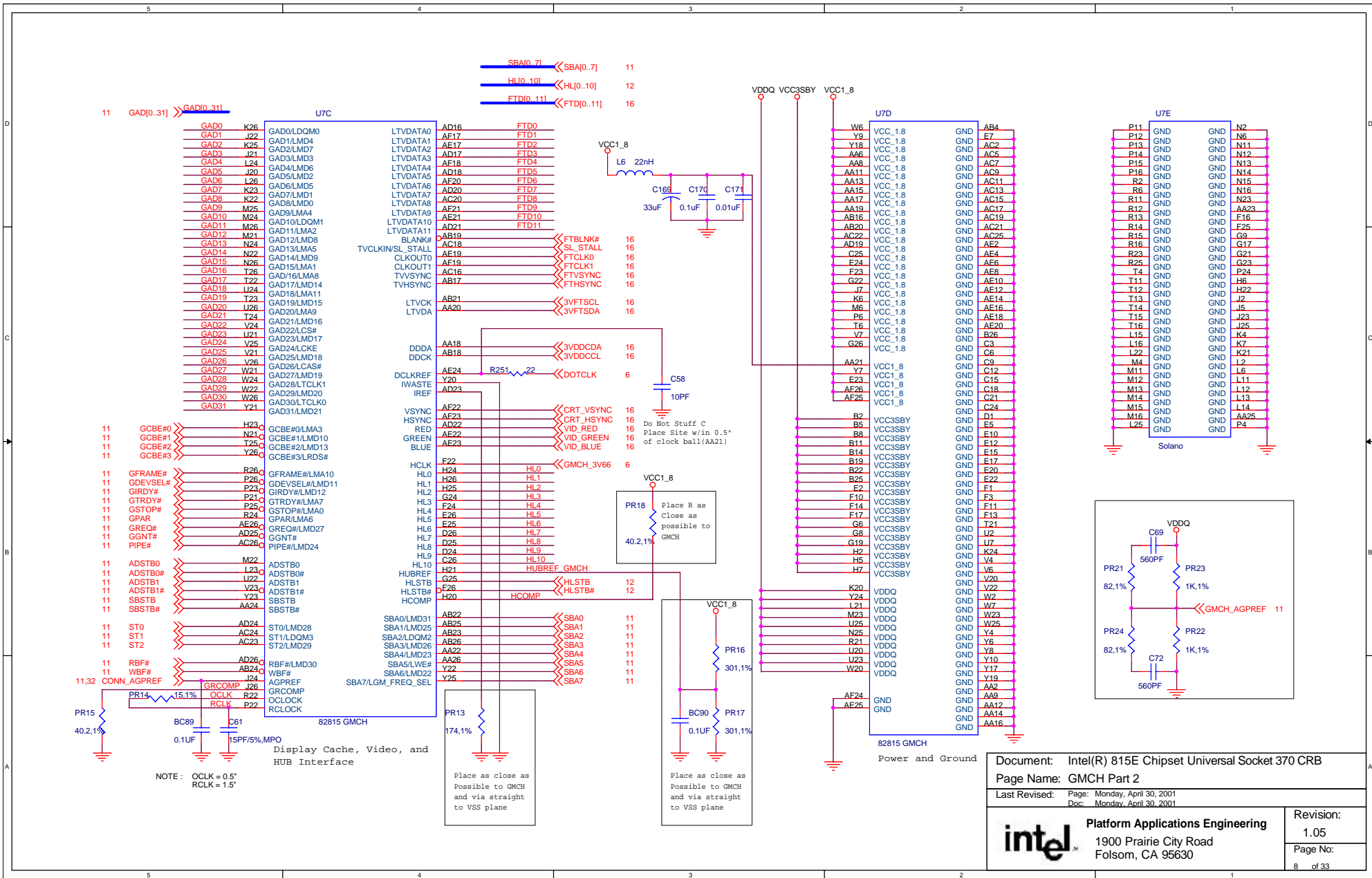

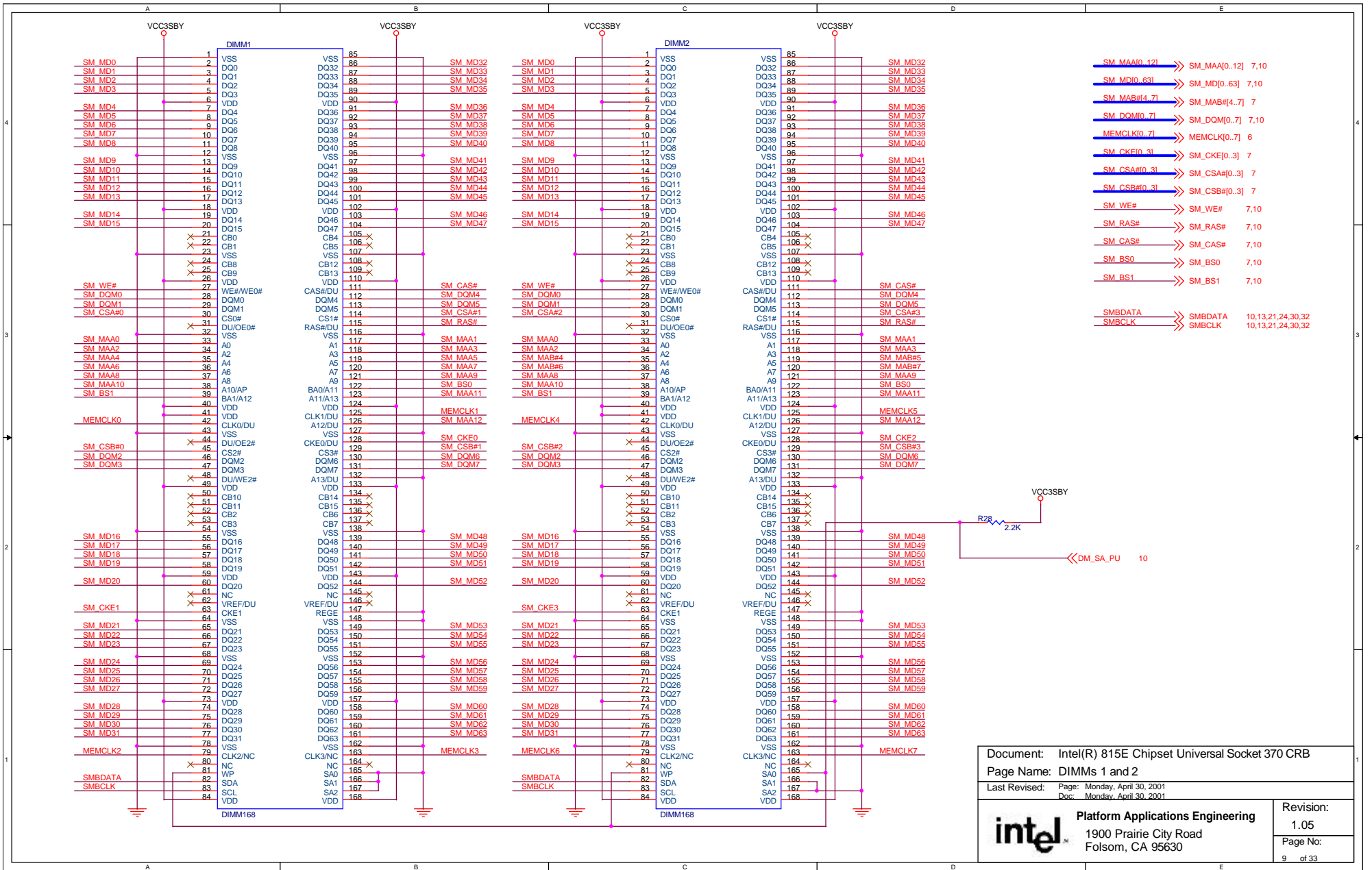

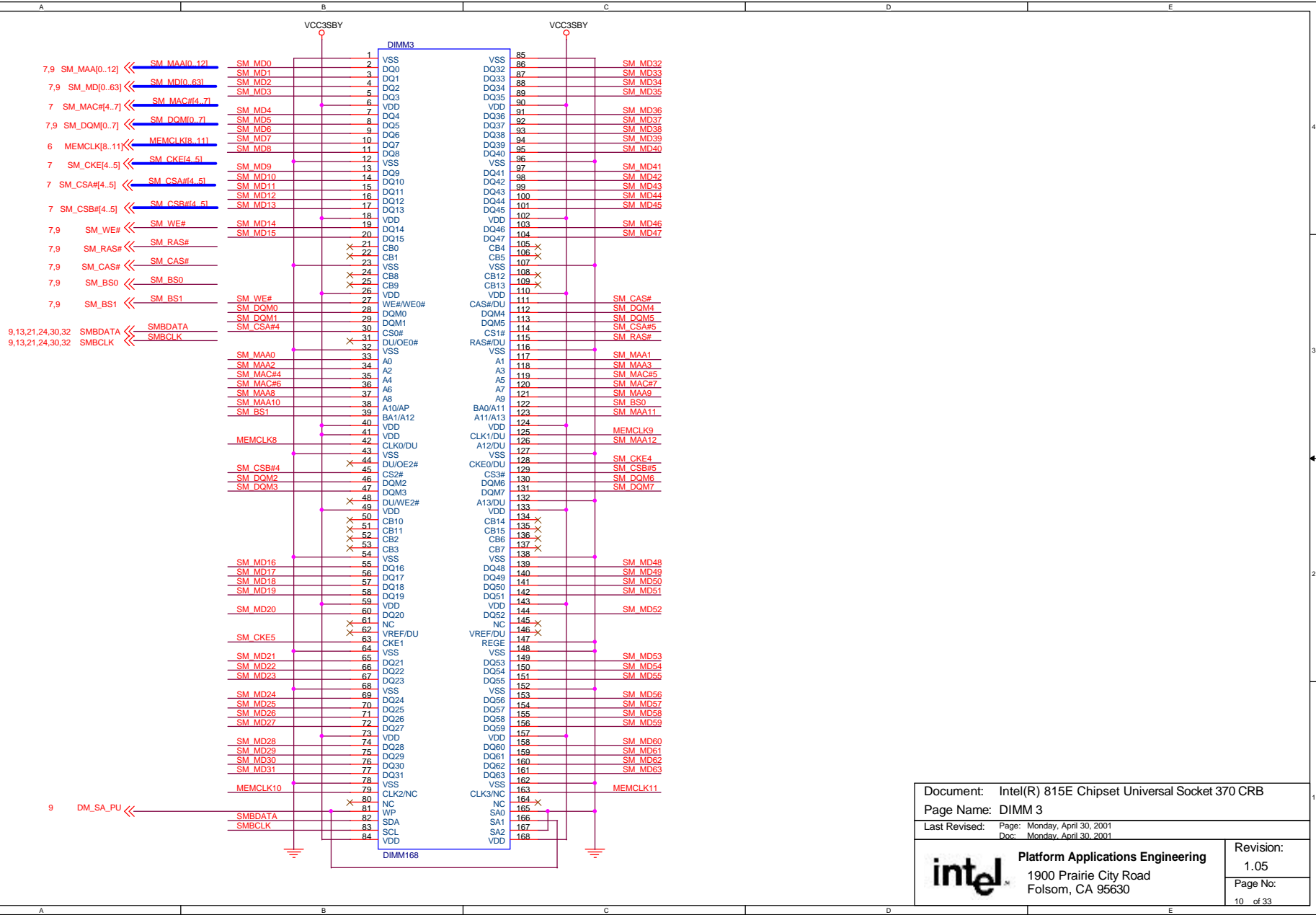

Document: Intel(R) 815E Chipset Universal Socket 370 CRB
 Page Name: DIMM 3

Last Revised: Page: Monday, April 30, 2001
 Doc: Monday, April 30, 2001

| | |
|--|----------------------|
|  Platform Applications Engineering 1900 Prairie City Road Folsom, CA 95630 | Revision: 1.05 |
| | Page No: 10 of 33 |

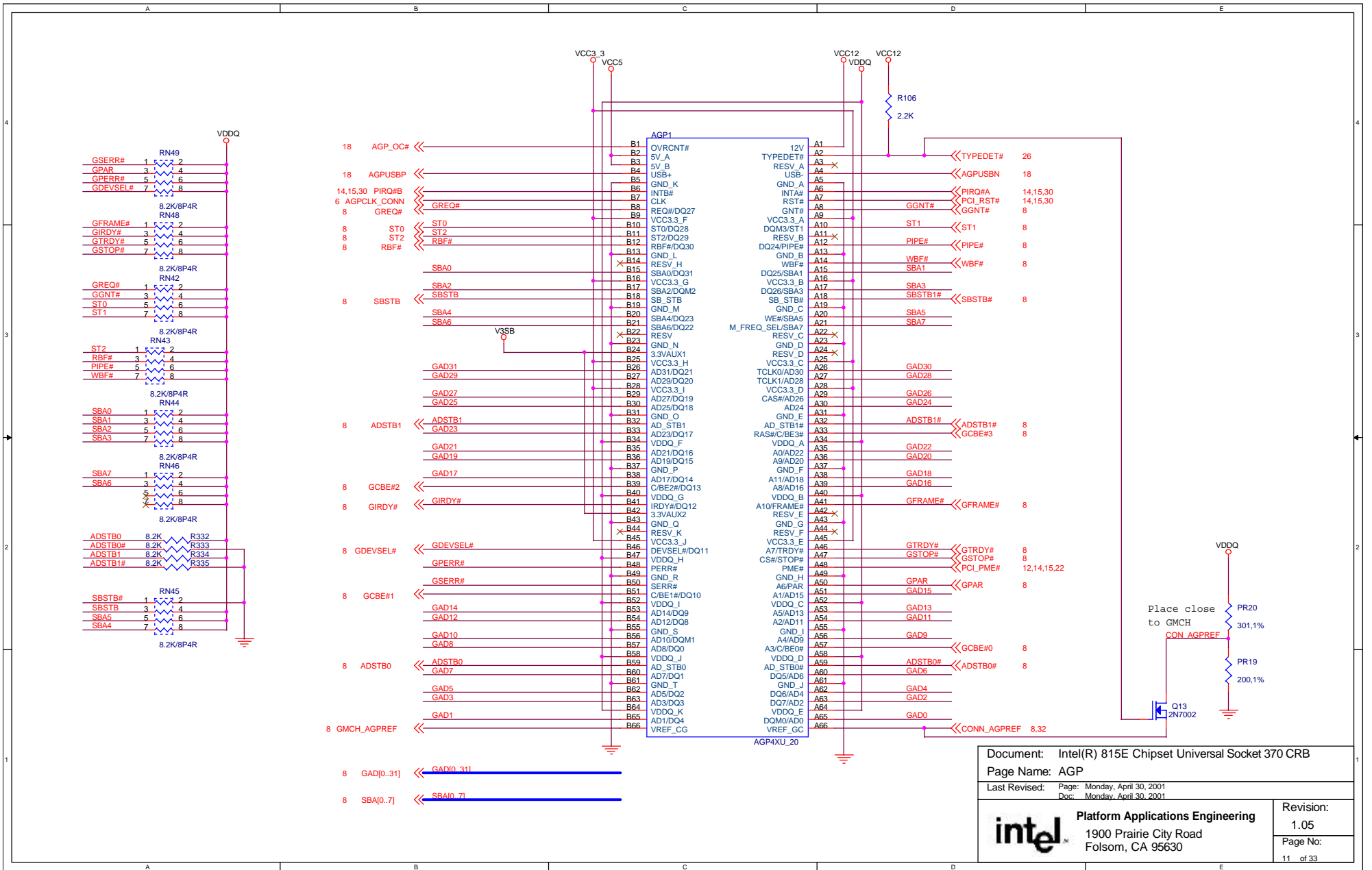

Document: Intel(R) 815E Chipset Universal Socket 370 CRB
 Page Name: AGP

Last Revised: Page: Monday, April 30, 2001
 Doc: Monday, April 30, 2001



Platform Applications Engineering
 1900 Prairie City Road
 Folsom, CA 95630

Revision:
 1.05
 Page No:
 11 of 33

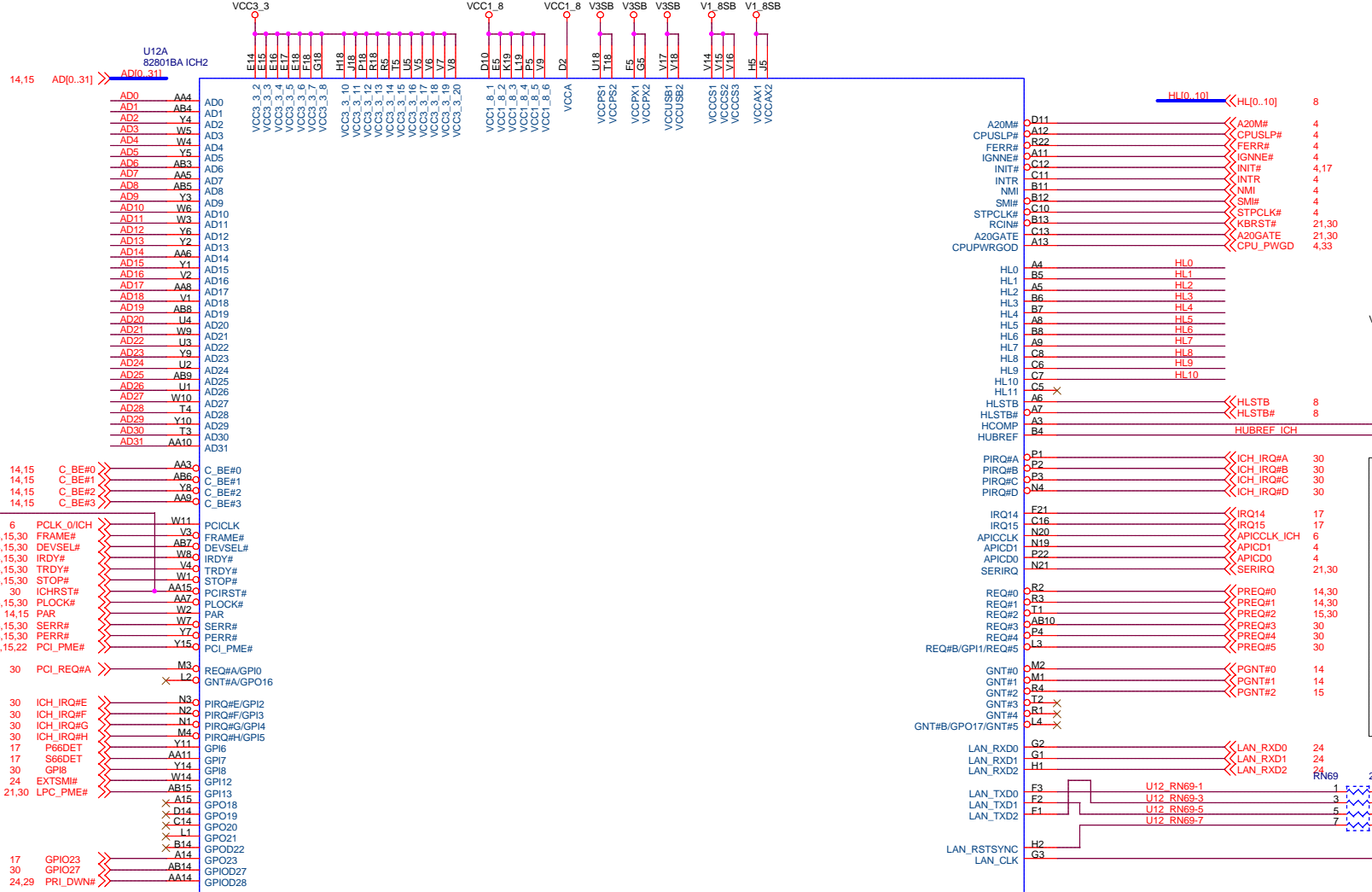

Document: Intel(R) 815E Chipset Universal Socket 370 CRB
 Page Name: ICH2 Part 1

Last Revised: Page: Monday, April 30, 2001
 Doc: Monday, April 30, 2001

| | |
|---|----------------------|
| Platform Applications Engineering 1900 Prairie City Road Folsom, CA 95630 | Revision: 1.05 |
| | Page No: 12 of 33 |

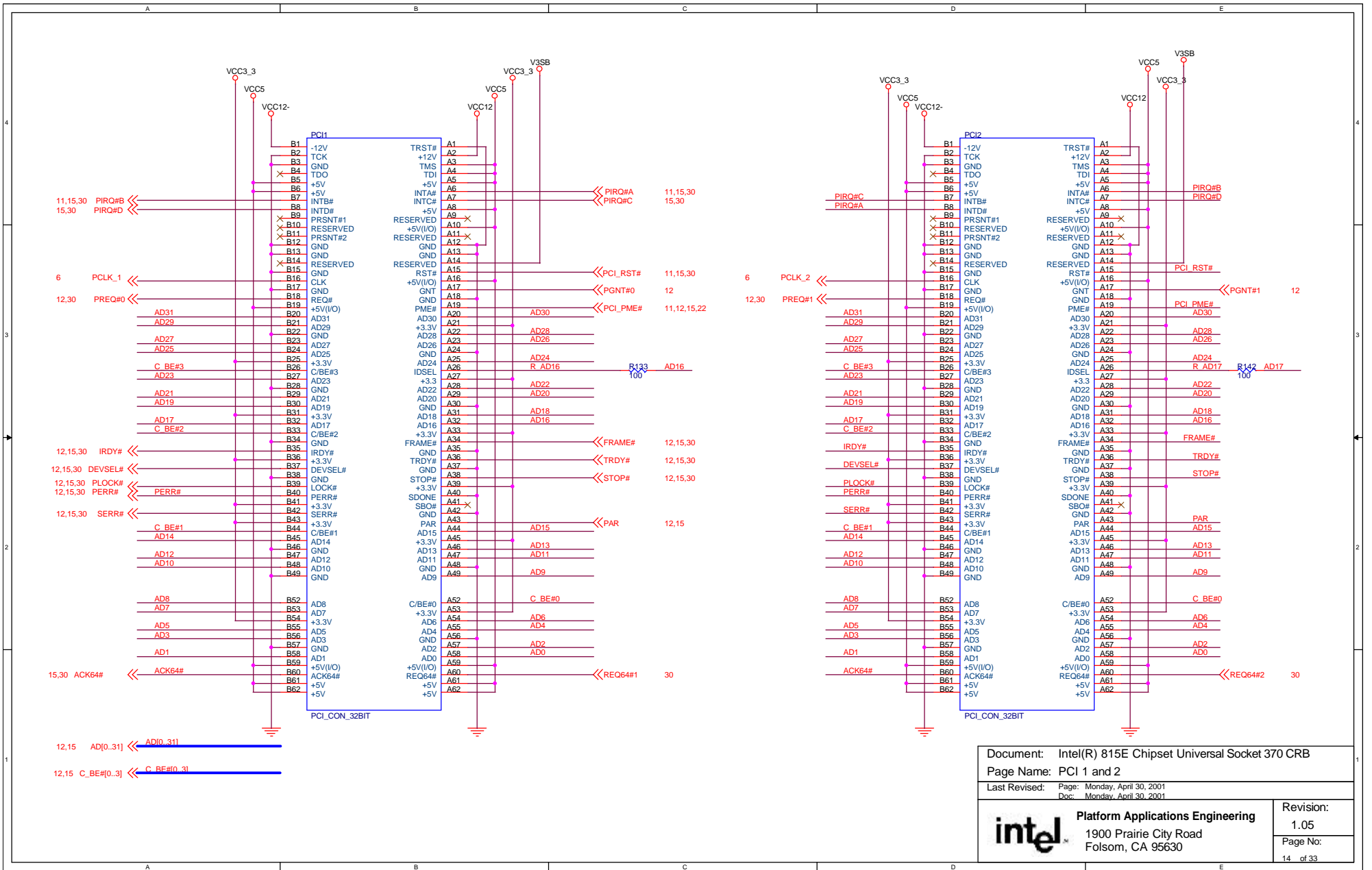

Document: Intel(R) 815E Chipset Universal Socket 370 CRB
 Page Name: PCI 1 and 2
 Last Revised: Page: Monday, April 30, 2001
 Doc: Monday, April 30, 2001

intel Platform Applications Engineering
 1900 Prairie City Road
 Folsom, CA 95630

Revision:
 1.05
 Page No:
 14 of 33

FWH

IDE

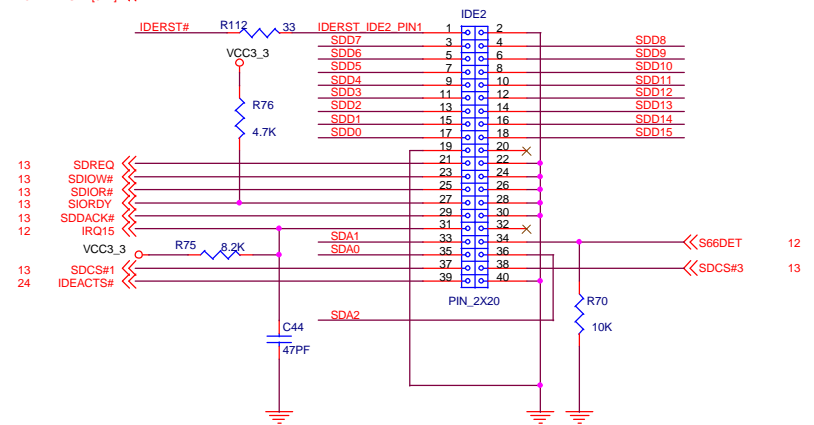
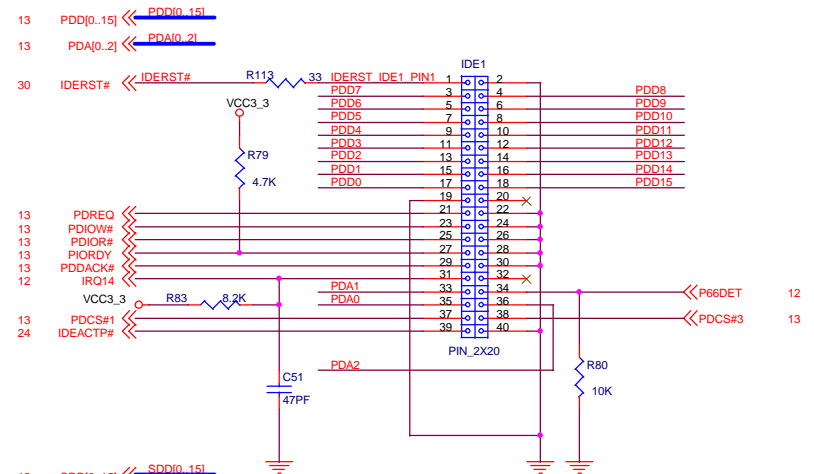
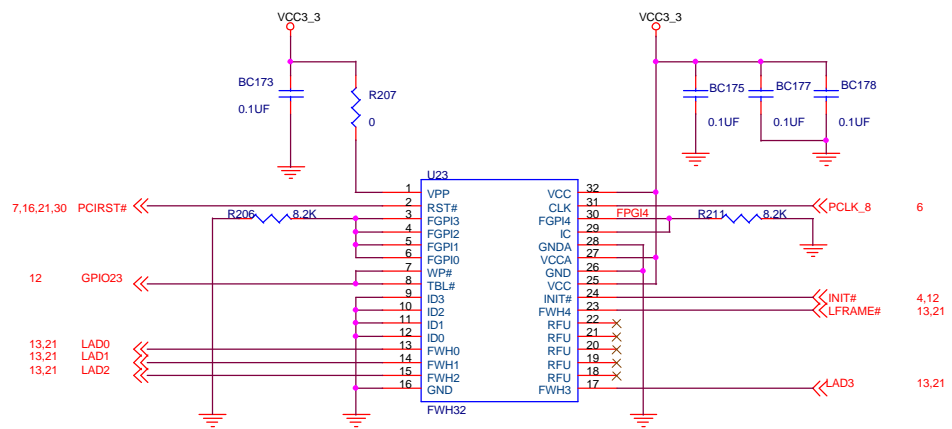

| | |
|--|---|
| Document: Intel(R) 815E Chipset Universal Socket 370 CRB | |
| Page Name: FWH and UDMA100 IDE | |
| Last Revised: | Page: Monday, April 30, 2001 Doc: Monday, April 30, 2001 |
| Platform Applications Engineering 1900 Prairie City Road Folsom, CA 95630 | Revision: 1.05 |
| | Page No: 17 of 33 |

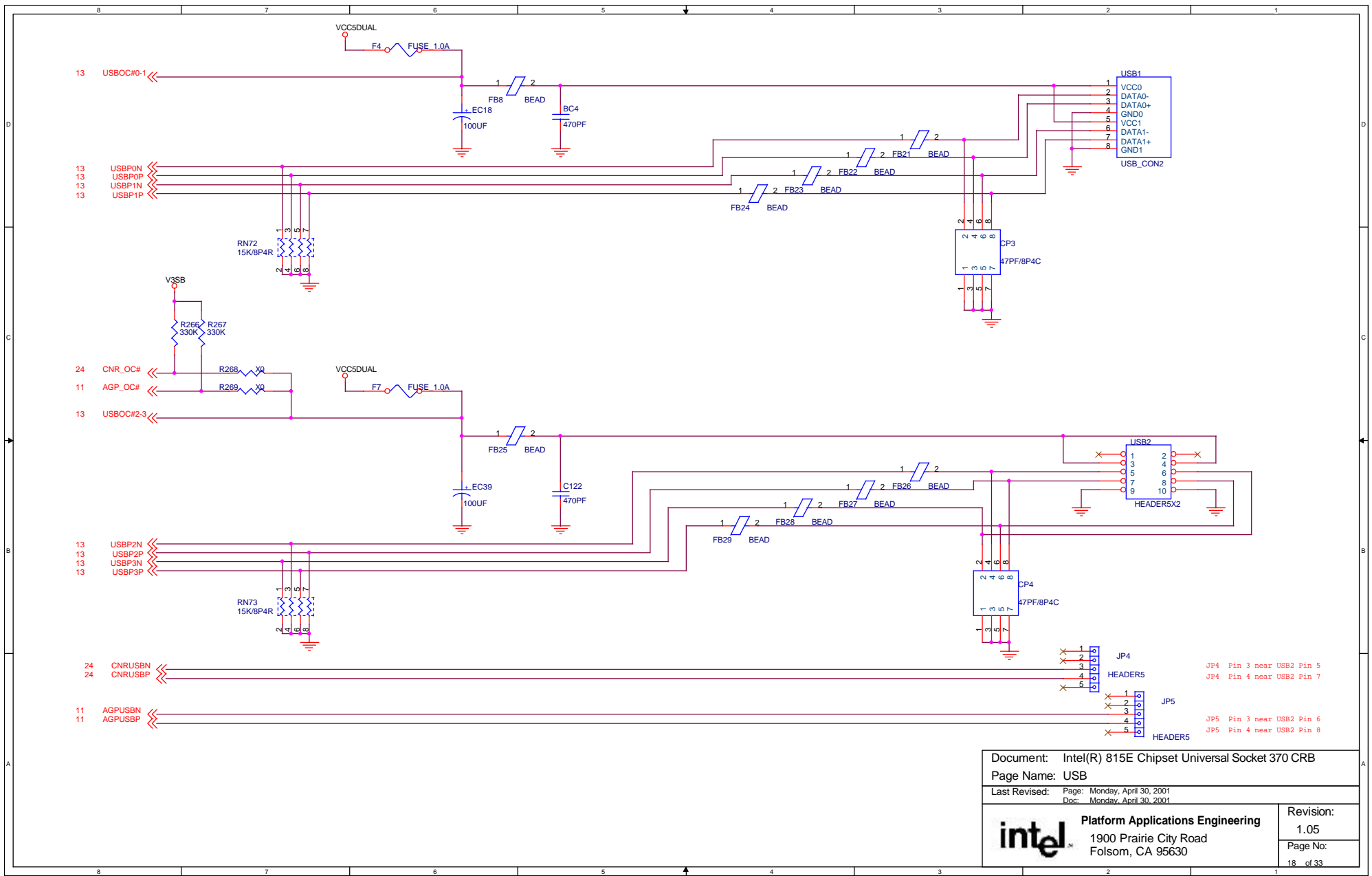

Document: Intel(R) 815E Chipset Universal Socket 370 CRB

Page Name: USB

Last Revised: Page: Monday, April 30, 2001

Doc: Monday, April 30, 2001



Platform Applications Engineering

1900 Prairie City Road
Folsom, CA 95630

Revision:

1.05

Page No:

18 of 33

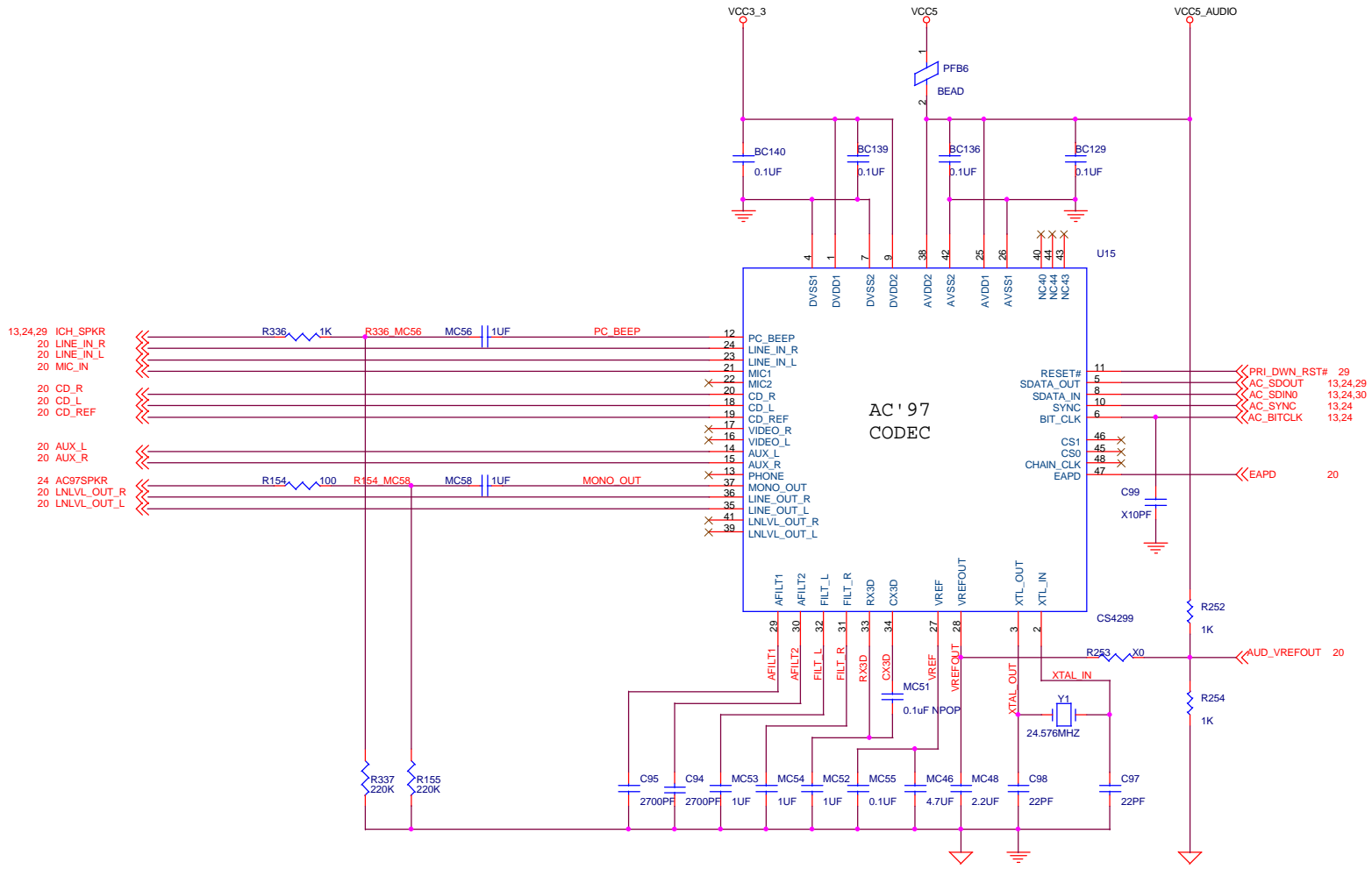

"SINGLE POINT CONNECTION"

| | |
|--|---|
| Document: Intel(R) 815E Chipset Universal Socket 370 CRB | |
| Page Name: AC'97 Codec | |
| Last Revised: | Page: Monday, April 30, 2001 Doc: Monday, April 30, 2001 |
|  Platform Applications Engineering 1900 Prairie City Road Folsom, CA 95630 | Revision: 1.05 |
| | Page No: 19 of 33 |

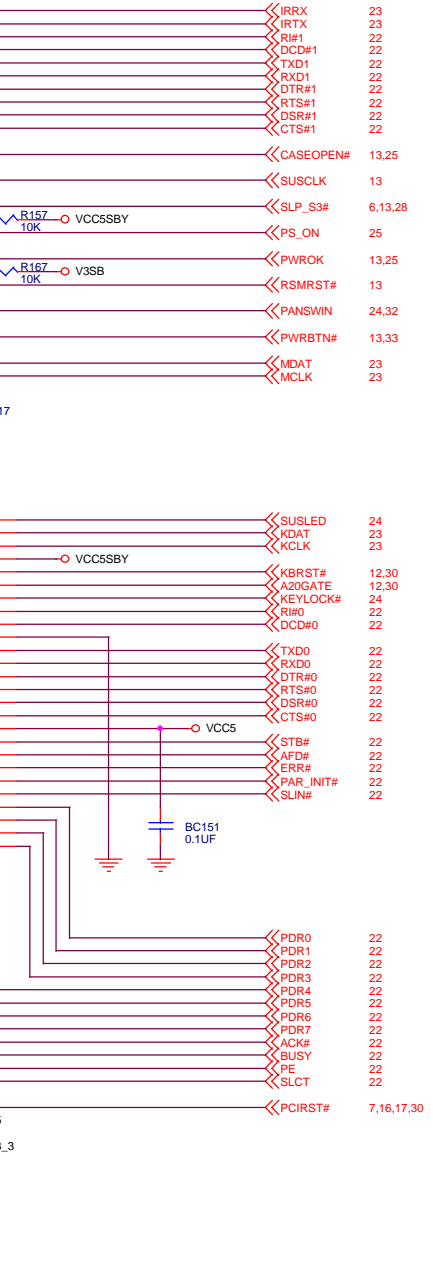
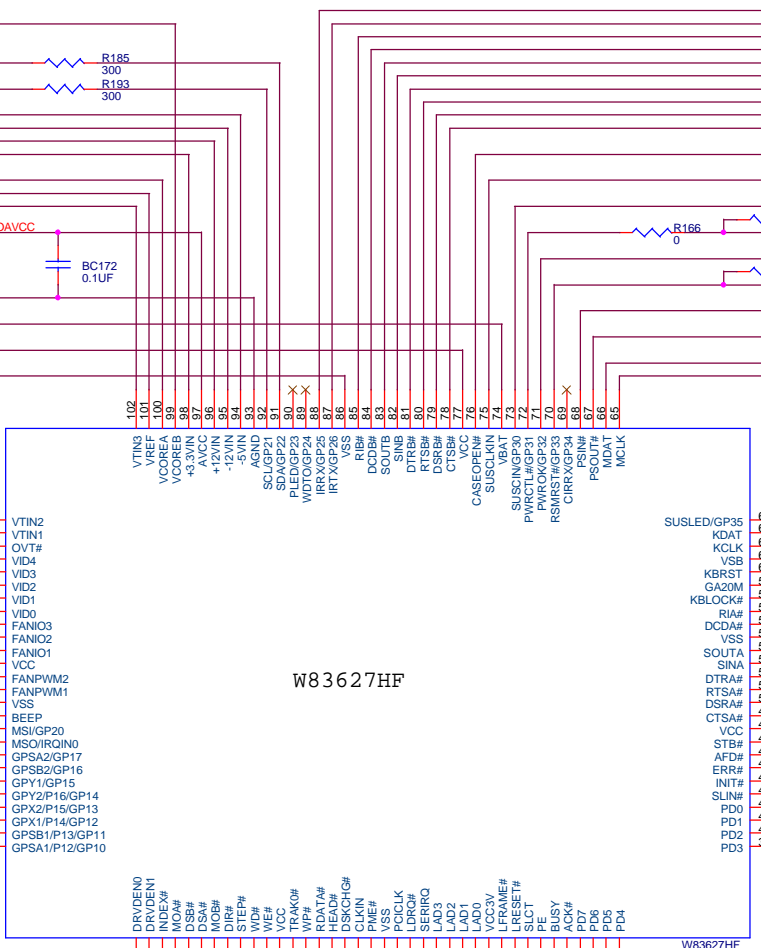
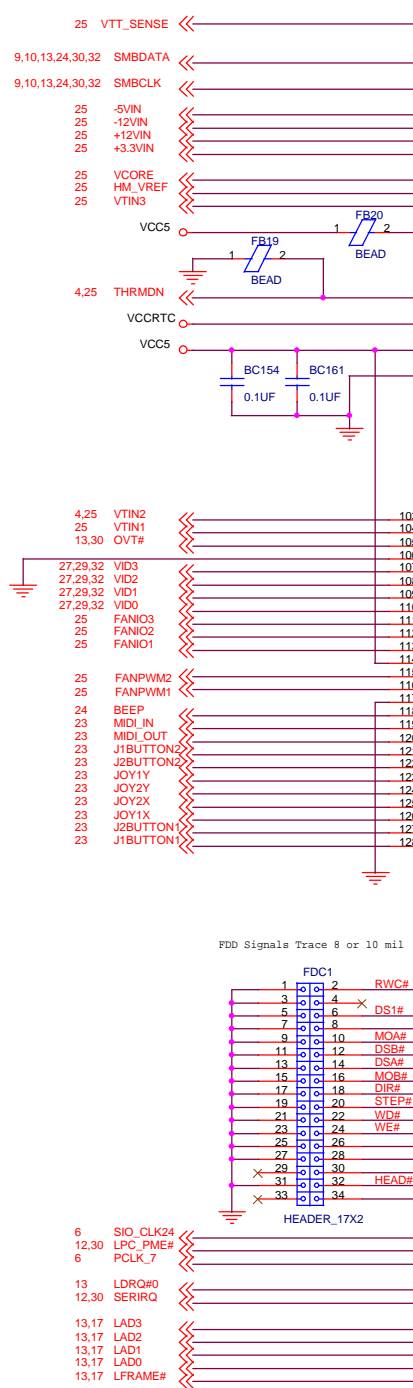

FDD Signals Trace 8 or 10 mil

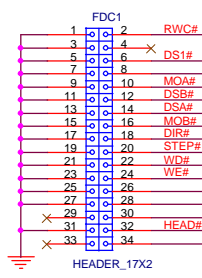

Document: Intel(R) 815E Chipset Universal Socket 370 CRB
Page Name: Super I/O and FDC
Last Revised: Page: Monday, April 30, 2001
Doc: Monday, April 30, 2001

| | |
|--|----------------------|
| Platform Applications Engineering 1900 Prairie City Road Folsom, CA 95630 | Revision: 1.05 |
| | Page No: 21 of 33 |

WAKE ON LAN

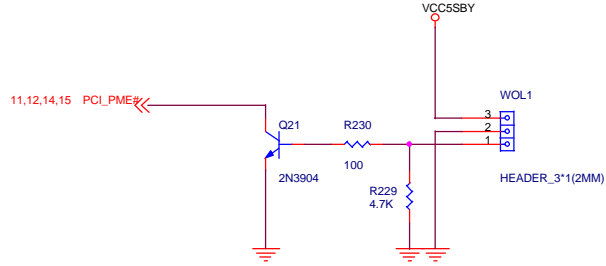

WAKE ON MODEM

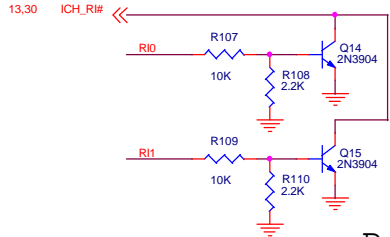

Parallel Port

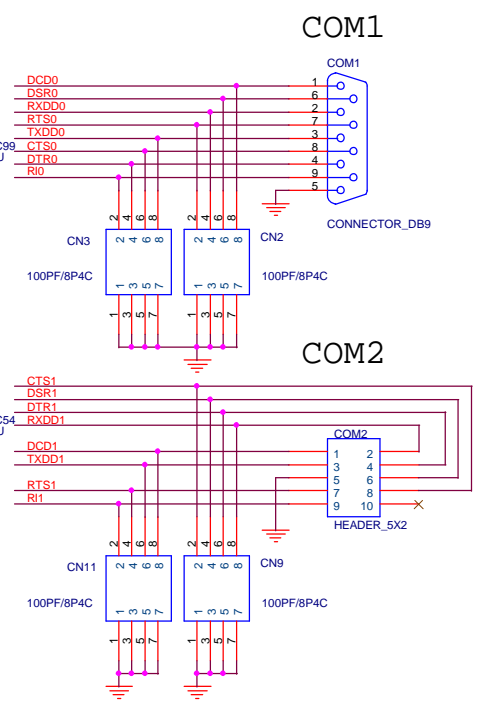
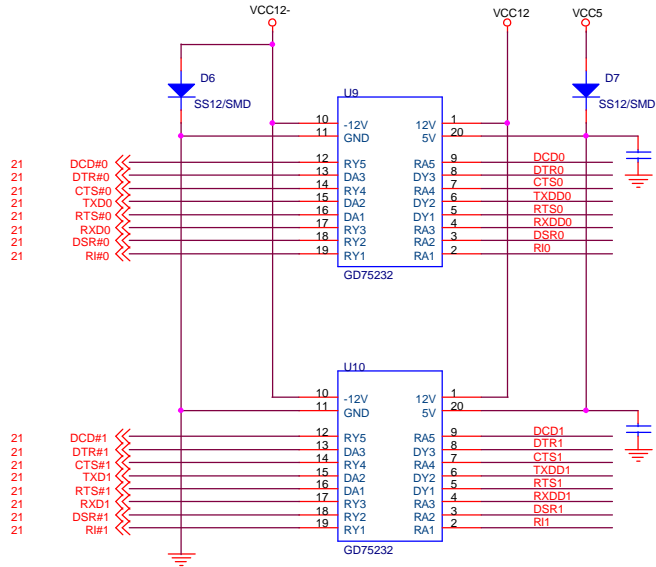
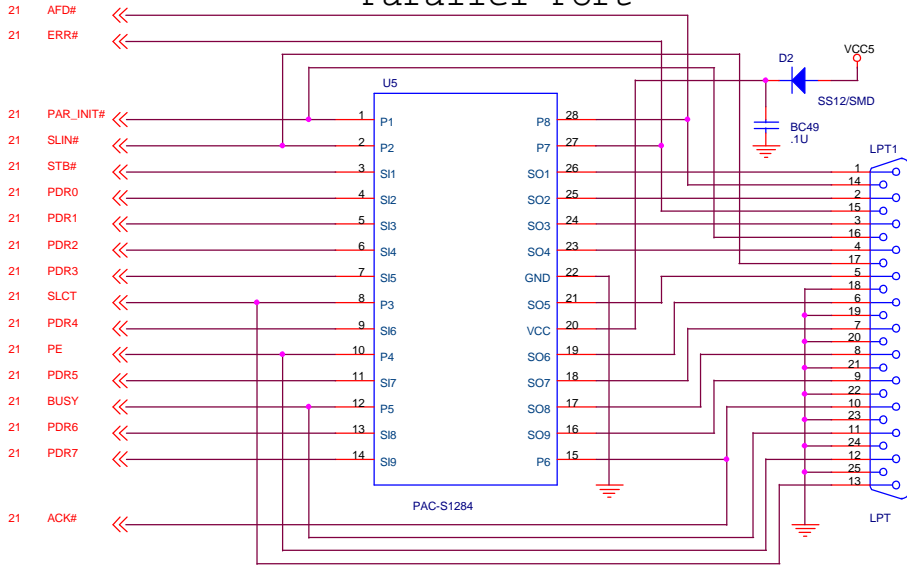

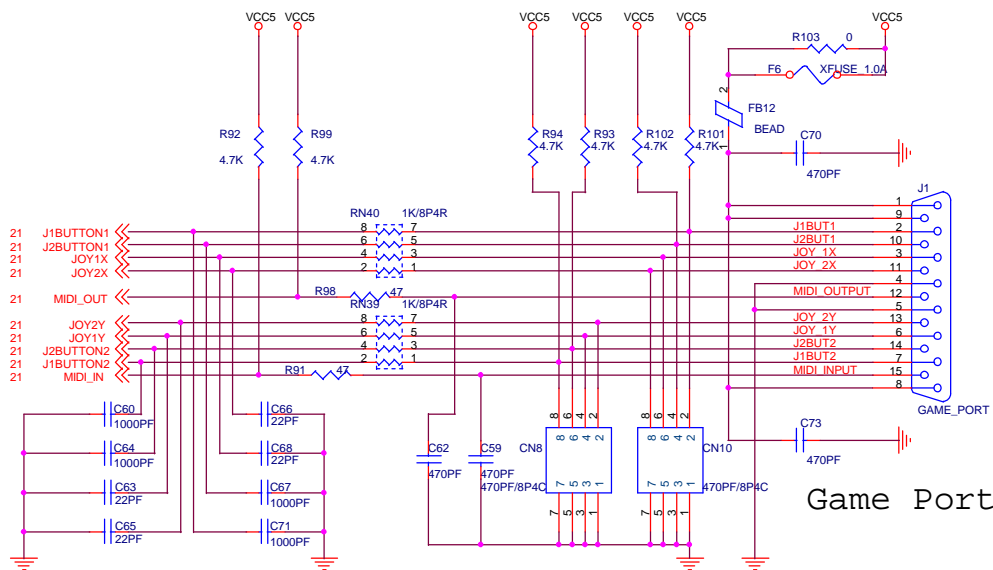

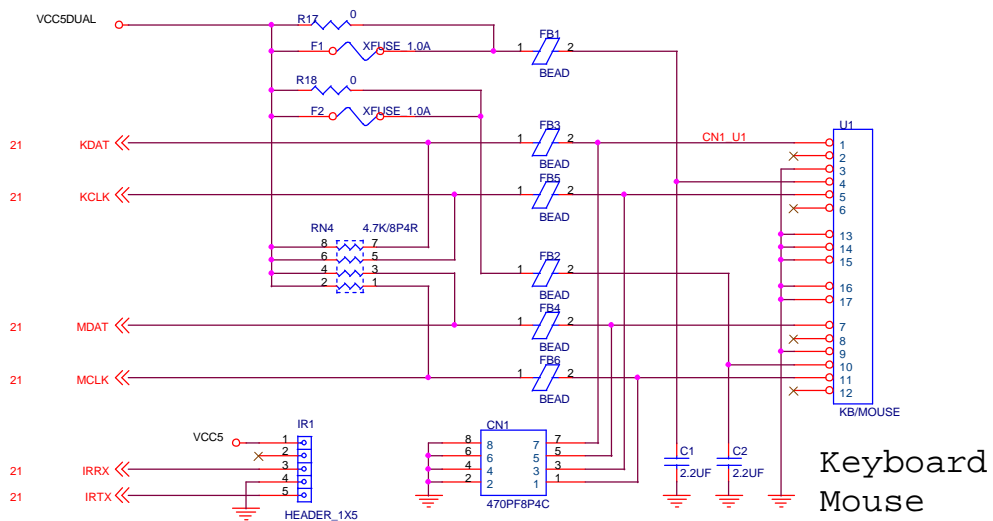

Game Port

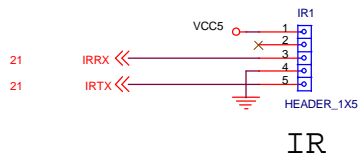

Keyboard Mouse



IR

| | |
|--|---|
| Document: | Intel(R) 815E Chipset Universal Socket 370 CRB |
| Page Name: | PS/2, Game, and IR |
| Last Revised: | Page: Monday, April 30, 2001 Doc: Monday, April 30, 2001 |
|  Platform Applications Engineering 1900 Prairie City Road Folsom, CA 95630 | Revision: 1.05 |
| | Page No: 23 of 33 |

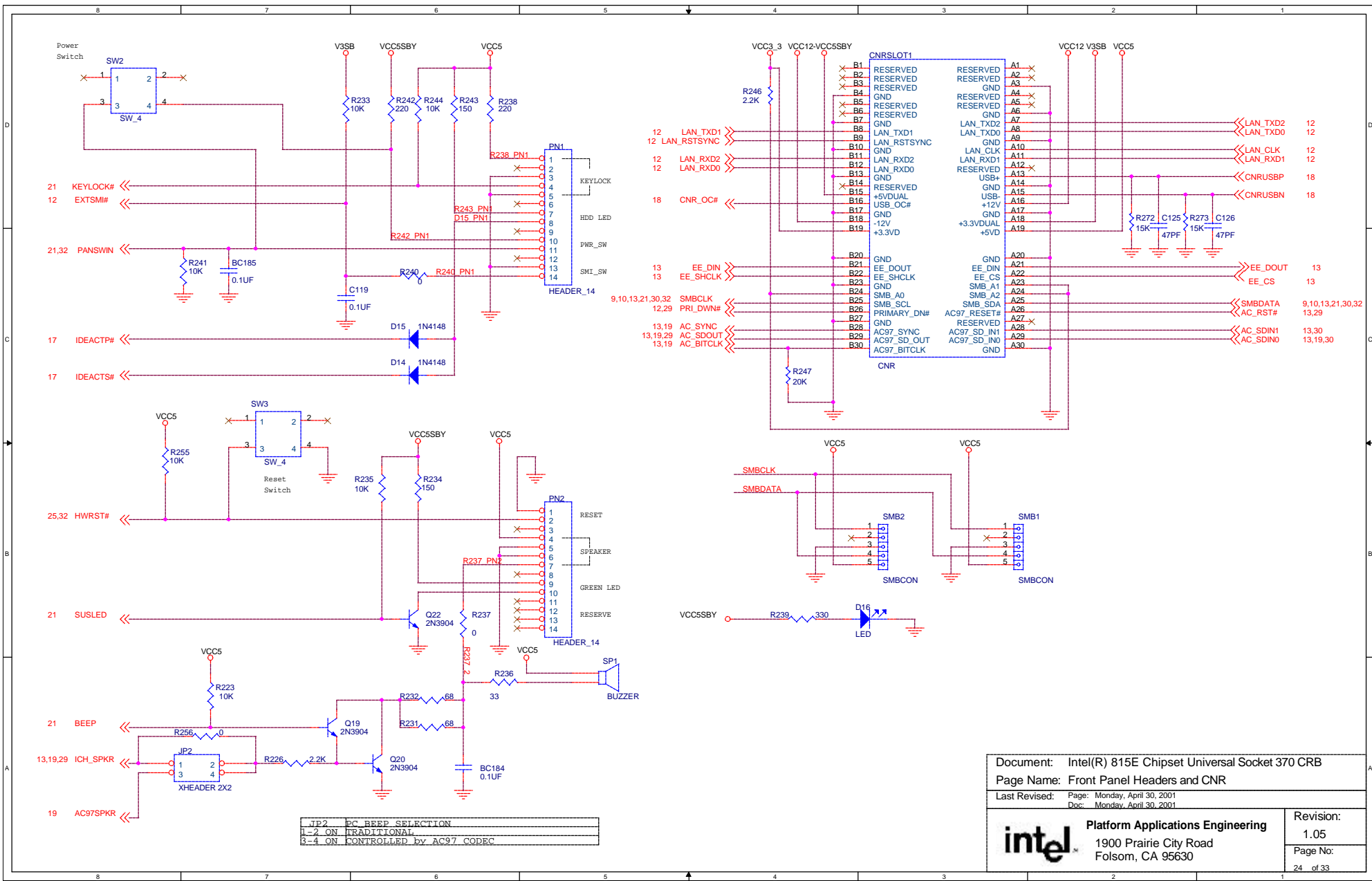

| | |
|--------|--------------------------|
| JP2 | PC BEEP SELECTION |
| 1-2 ON | TRADITIONAL |
| 3-4 ON | CONTROLLED by AC97 CODEC |

Document: Intel(R) 815E Chipset Universal Socket 370 CRB
Page Name: Front Panel Headers and CNR

Last Revised: Page: Monday, April 30, 2001
Doc: Monday, April 30, 2001

| | |
|--|----------------------|
| Platform Applications Engineering 1900 Prairie City Road Folsom, CA 95630 | Revision: 1.05 |
| | Page No: 24 of 33 |

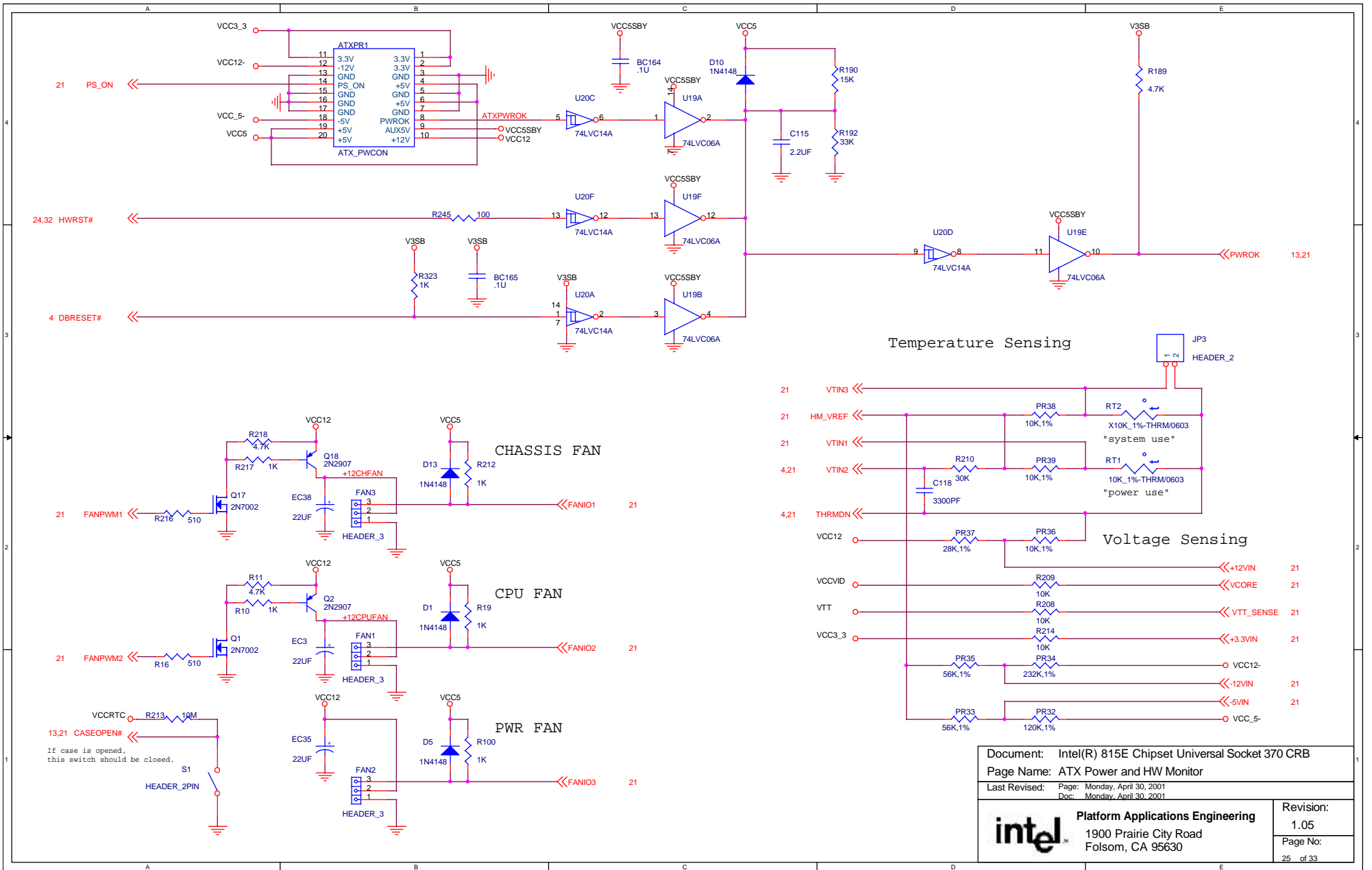

Document: Intel(R) 815E Chipset Universal Socket 370 CRB
 Page Name: ATX Power and HW Monitor

Last Revised: Page: Monday, April 30, 2001
 Doc: Monday, April 30, 2001

intel Platform Applications Engineering
 1900 Prairie City Road
 Folsom, CA 95630

Revision:
 1.05
 Page No:
 25 of 33

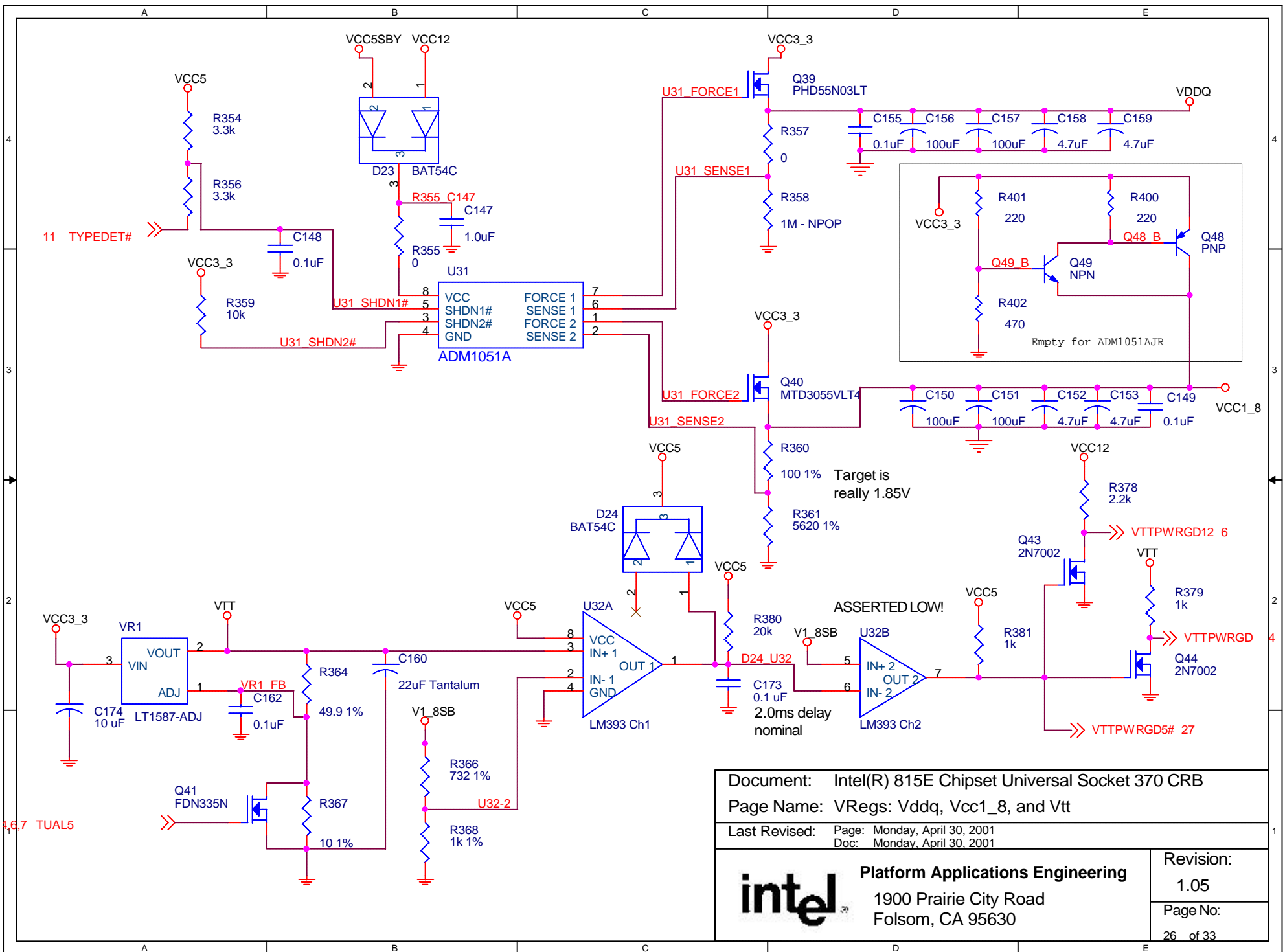

Document: Intel(R) 815E Chipset Universal Socket 370 CRB
 Page Name: VRegs: Vddq, Vcc1_8, and Vtt
 Last Revised: Page: Monday, April 30, 2001
 Doc: Monday, April 30, 2001

| | |
|--|----------------------|
|  Platform Applications Engineering 1900 Prairie City Road Folsom, CA 95630 | Revision: 1.05 |
| | Page No: 26 of 33 |

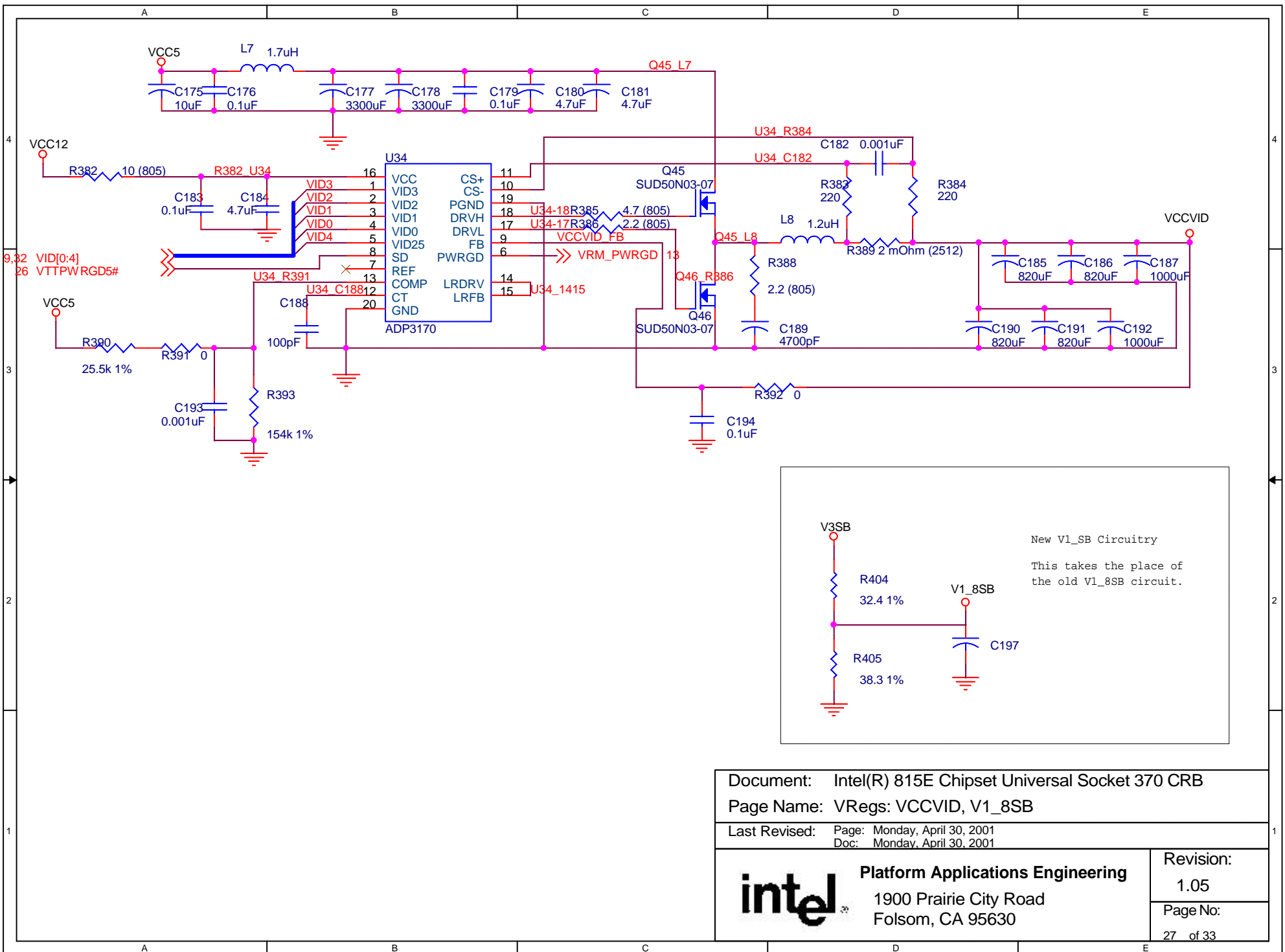

| | |
|--|---|
| Document: Intel(R) 815E Chipset Universal Socket 370 CRB | |
| Page Name: VRegs: VCCVID, V1_8SB | |
| Last Revised: | Page: Monday, April 30, 2001 Doc: Monday, April 30, 2001 |
|  Platform Applications Engineering 1900 Prairie City Road Folsom, CA 95630 | Revision: 1.05 |
| | Page No: 27 of 33 |

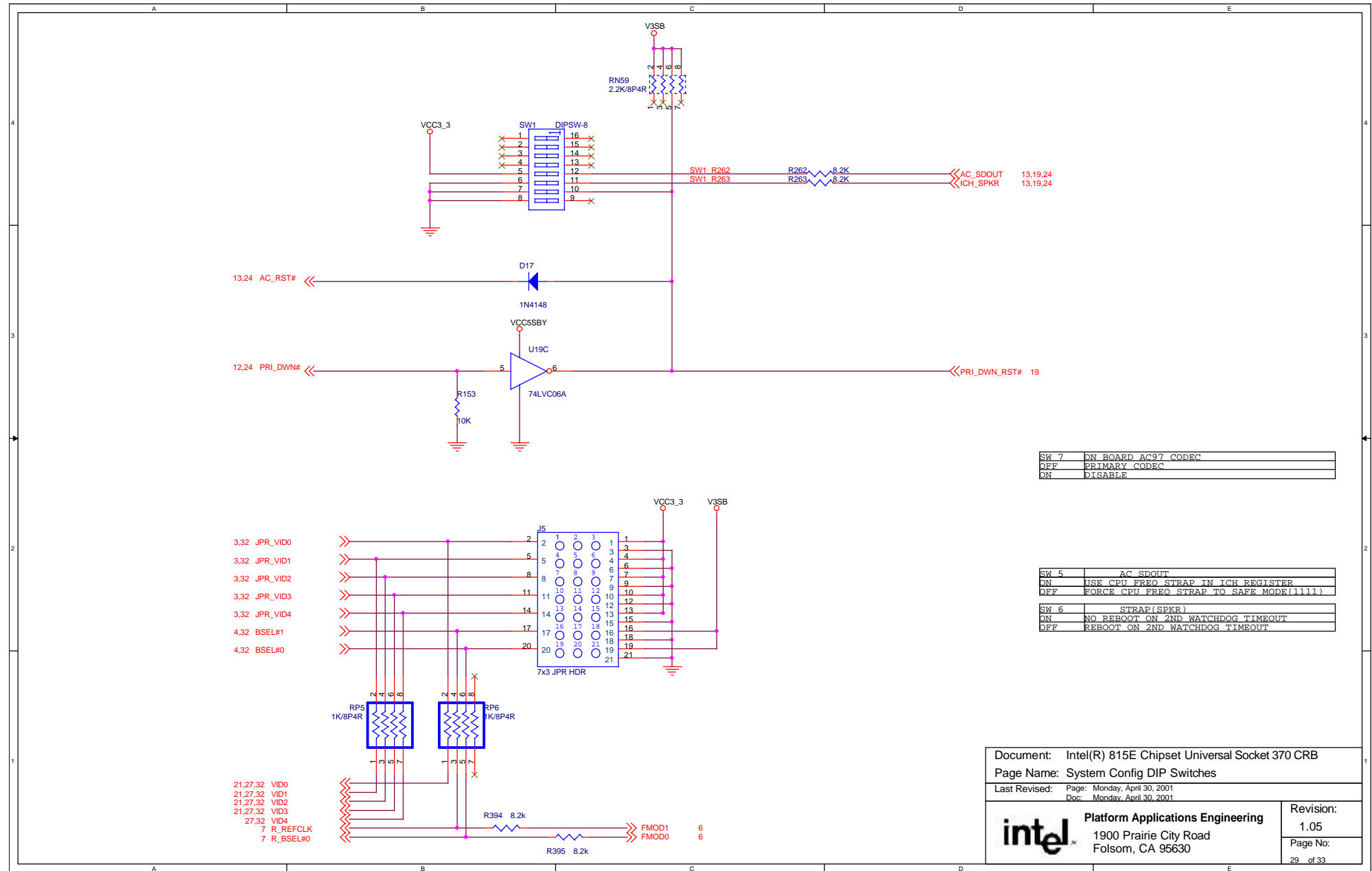

| | |
|------|---------------------|
| SW 7 | ON BOARD AC97 CODEC |
| OFF | PRIMARY CODEC |
| ON | DISABLE |

| | |
|------|---|
| SW 5 | AC SDOUT |
| ON | USE CPU FREQ STRAP IN ICH REGISTER |
| OFF | FORCE CPU FREQ STRAP TO SAFE MODE(1111) |

| | |
|------|-----------------------------------|
| SW 6 | STRAP(SPKR) |
| ON | NO REBOOT ON 2ND WATCHDOG TIMEOUT |
| OFF | REBOOT ON 2ND WATCHDOG TIMEOUT |

Document: Intel(R) 815E Chipset Universal Socket 370 CRB
Page Name: System Config DIP Switches

Last Revised: Page: Monday, April 30, 2001
Doc: Monday, April 30, 2001

| | |
|--|----------------------|
| Platform Applications Engineering 1900 Prairie City Road Folsom, CA 95630 | Revision: 1.05 |
| | Page No: 29 of 33 |

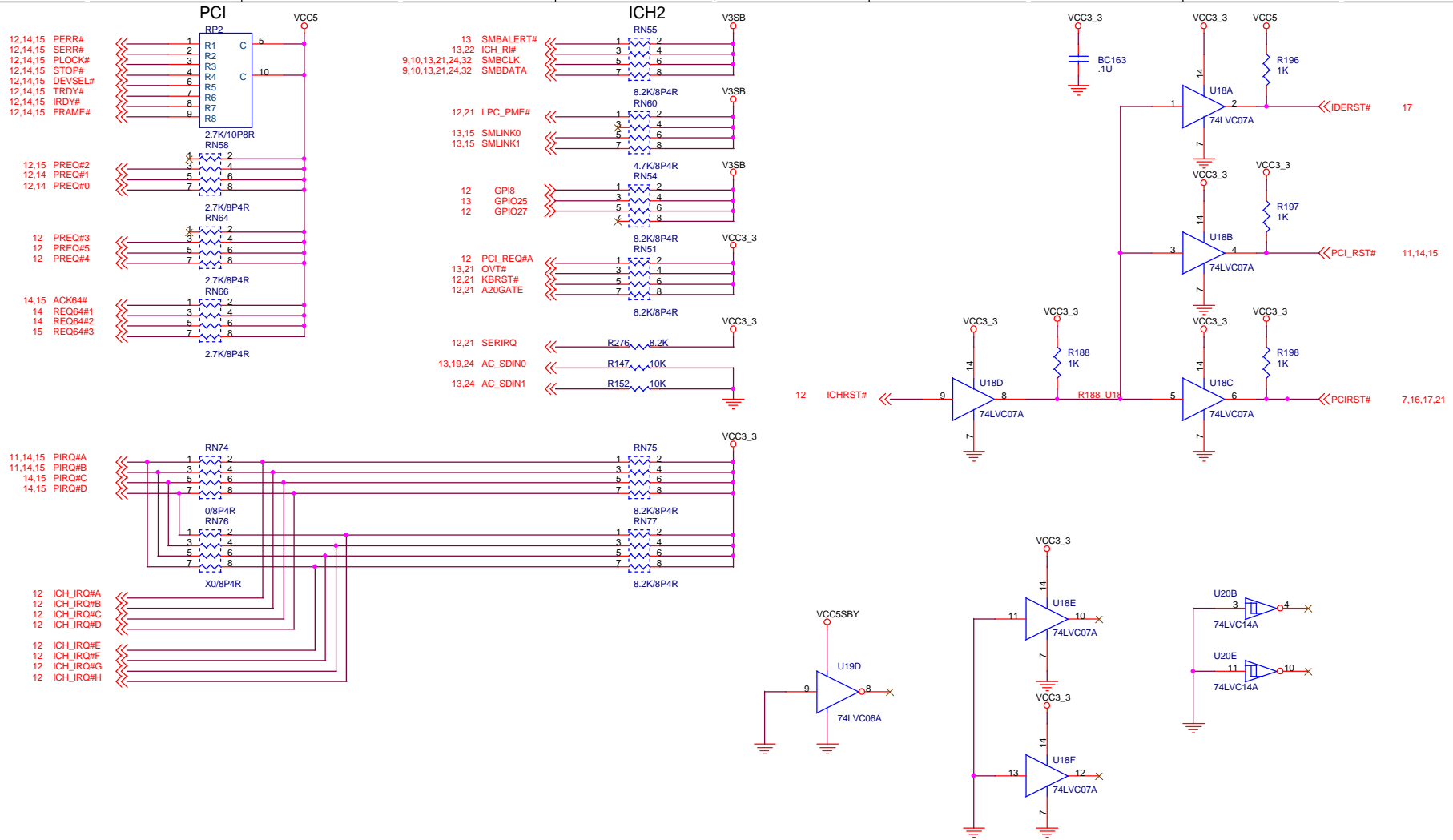

Document: Intel(R) 815E Chipset Universal Socket 370 CRB

Page Name: Pullup/Pulldown Rs and Unused Gates

Last Revised: Page: Monday, April 30, 2001
 Doc: Monday, April 30, 2001



Platform Applications Engineering
 1900 Prairie City Road
 Folsom, CA 95630

Revision:

1.05

Page No:

30 of 33

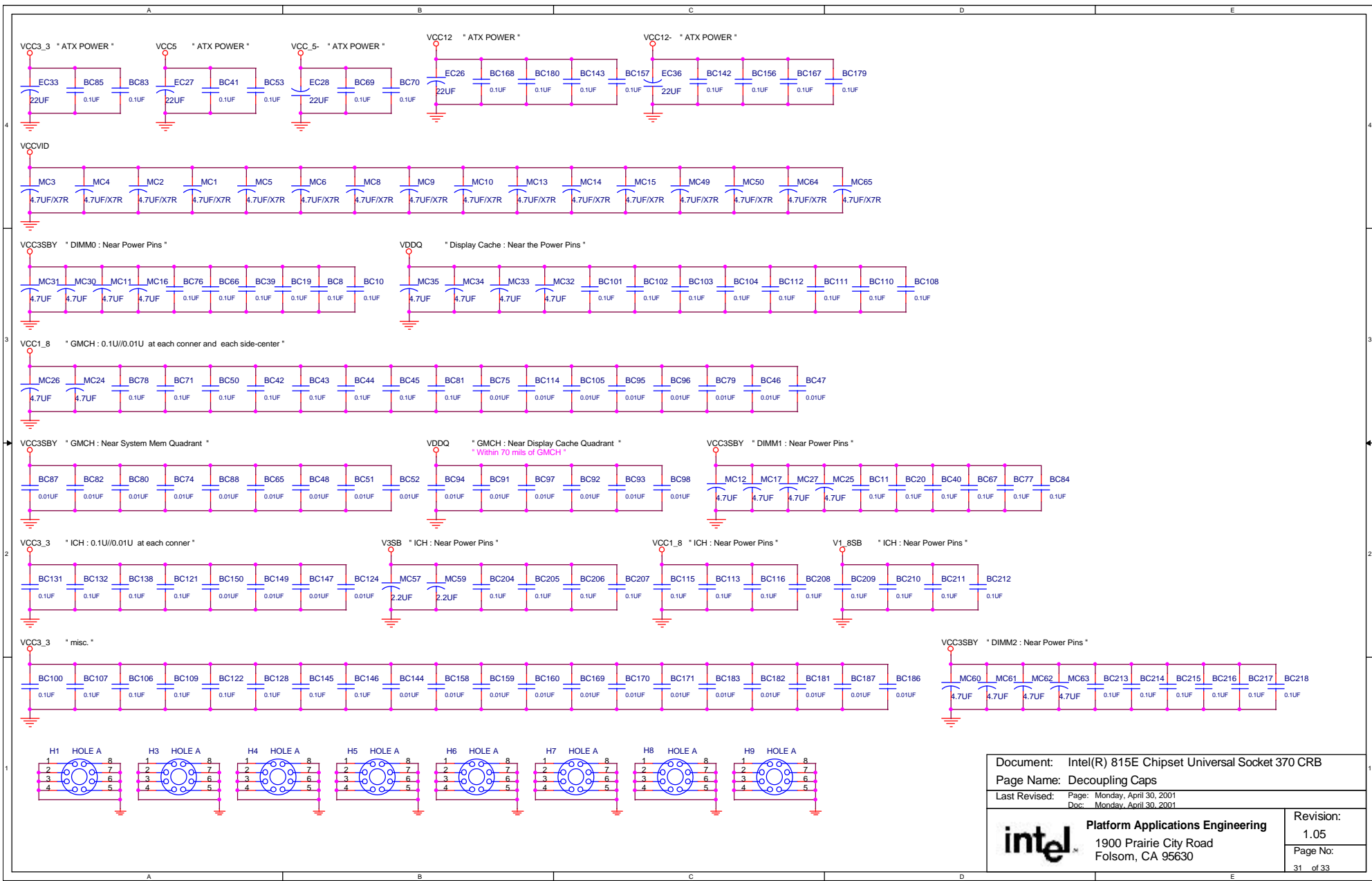

| | |
|--|------------------------------|
| Document: Intel(R) 815E Chipset Universal Socket 370 CRB | |
| Page Name: Decoupling Caps | |
| Last Revised: | Page: Monday, April 30, 2001 |
| | Doc: Monday, April 30, 2001 |
|  Platform Applications Engineering 1900 Prairie City Road Folsom, CA 95630 | Revision: 1.05 |
| | Page No: 31 of 33 |

21,27,29 VID[4:0] >>>
 3,29 JPR_VID[4:0] >>>

21,24 PANSWIN <<<
 24,25 HWRST# <<<

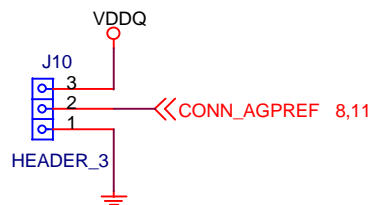
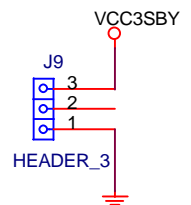
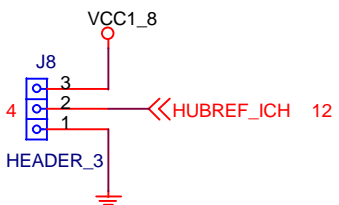
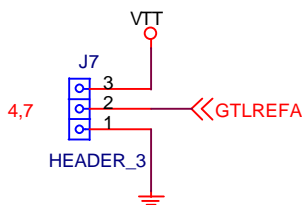
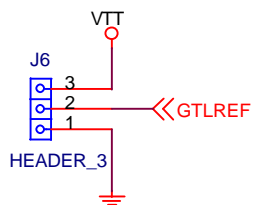
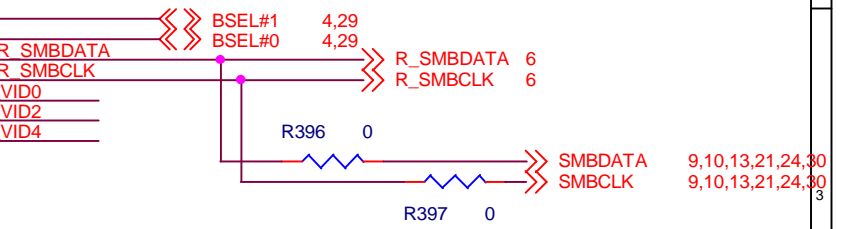
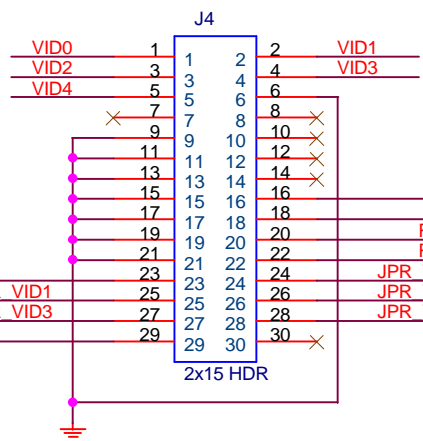

| | |
|--|---|
| Document: Intel(R) 815E Chipset Universal Socket 370 CRB | |
| Page Name: Internal Debug headers | |
| Last Revised: | Page: Monday, April 30, 2001 Doc: Monday, April 30, 2001 |
|  Platform Applications Engineering 1900 Prairie City Road Folsom, CA 95630 | Revision: 1.05 |
| | Page No: 32 of 33 |

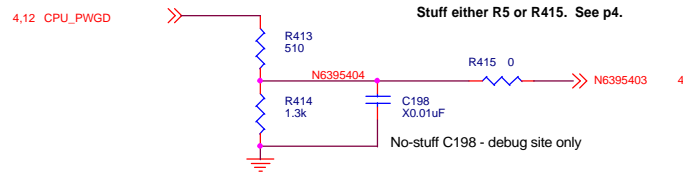
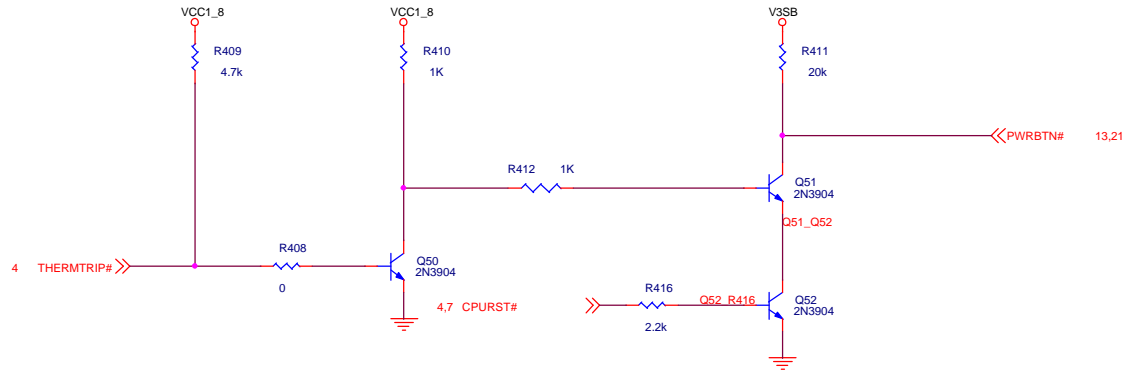

| | | | |
|--|--|-----------|--|
| Document: Intel(R) 815E Chipset Universal Socket 370 CRB | | Revision: | |
| Page Name: Thermtrip | | 1.05 | |
| Last Revised: Page: Monday, April 30, 2001 | | Page No: | |
| Doc: Monday, April 30, 2001 | | 33 of 33 | |
|  Platform Applications Engineering 1900 Prairie City Road Folsom, CA 95630 | | | |