

Model Name:
8GPNXP Duo

Revision 05/10/2004
1.01

SHEET TITLE

01	COVER SHEET
02	BLOCK DIAGRAM
03	BOM & PCB MODIFY HISTORY
04	P4_LGA775_A
05	P4_LGA775_B
06	P4_LGA775_C
07	P4_LGA775_D
08	GMCH-GRANTS DALE_HOST
09	GMCH-GARNTSDALE_DDR
10	GMCH-GRANTS DALE_PCI E, DMI
11	GMCH-GRANTS DALE_INT VGA
12	GMCH-GRANTS DALE_GND
13	GMCH-GRANTS DALE_PWR
14	DDR II CHANNEL A 1,2
15	DDR II CHANNEL A 3
16	DDR II CHANNEL B 1,2
17	DDR II CHANNEL B 3
18	DDR II TERMINATION
19	PCI EXPRESS*16 SLOT
20	ICH6 PCI, USB, DMI, LAN
21	ICH6 IDE, GPIO, SATA, CTRL
22	ICH6 VCC, GND
23	FWH
24	GB/CK410M CLOCK.
25	PCI SLOT 1, 2,3
26	PCI EXPRESS*1 SLOT 1,2,3
27	H/W MONITOR

SHEET TITLE

28	IDE
29	KB_PS2, GAME PORT
30	FRONT PANEL
31	FRONT USB CONNECTOR
32	CPU_FAN & SYS_FAN
33	AZALIA CODEC ALC880
34	AUDIO JACK 1
35	AUDIO JACK 2
36	MARVELL 88E8001 LAN
37	DISCRETE POWER
38	CYPRESS USB HUB
39	ITE 8712GB
40	COM_LPT
41	MARVELL 88E8050 LAN
42	SATA 3114
43	TI 1394B-1
44	TI 1394B-2
45	ATX POWER CONN.
46	DPS-1
47	DPS-2
48	DPS-3
49	TABLE

Intel Confidential

Title		Cover Sheet	
Size	Document Number	Rev	
Custom	8GPNXP DUO	1.01	
Date:	星期四, 五月 20, 2004	Sheet	1 of 49

BLOCK DIAGRAM

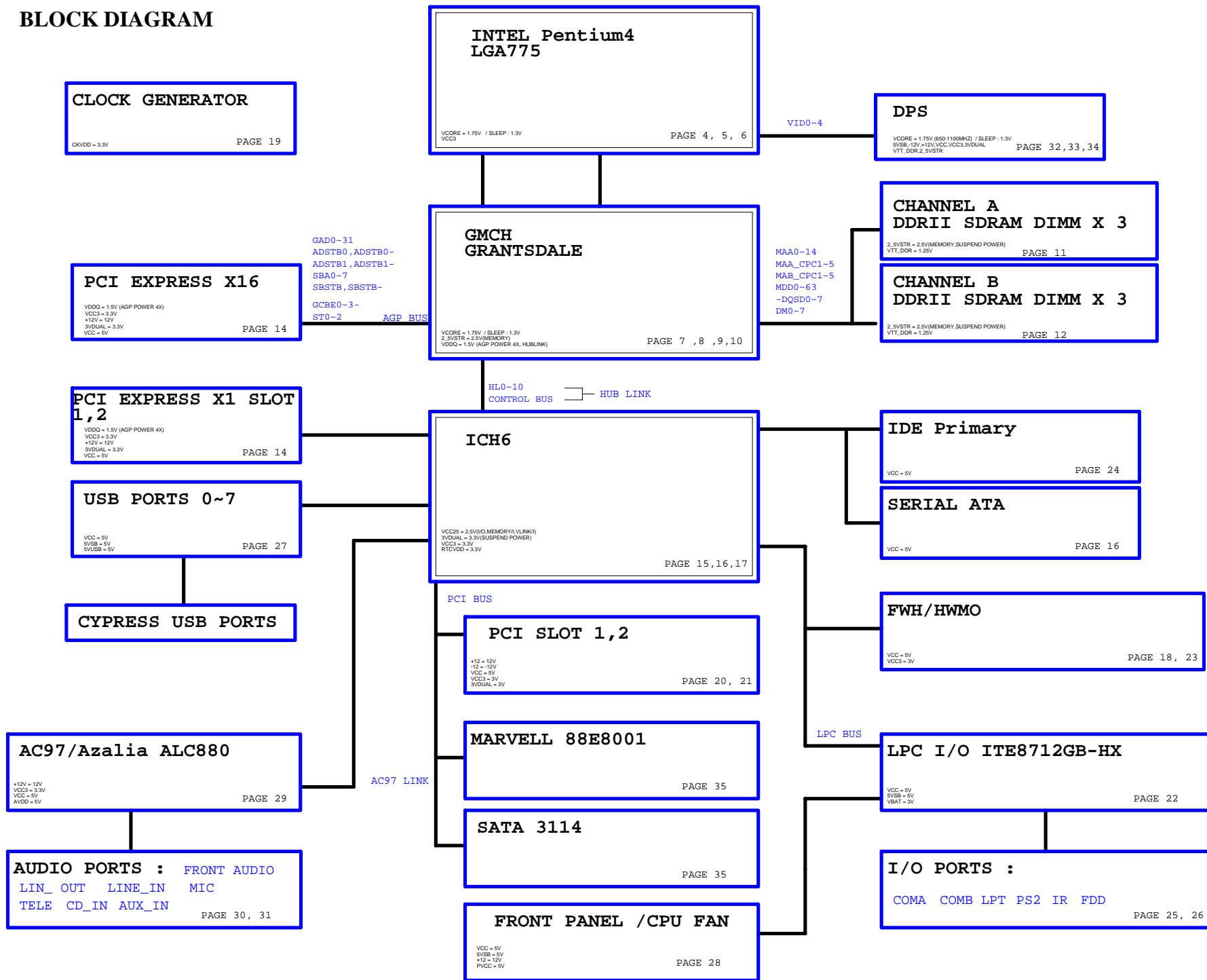

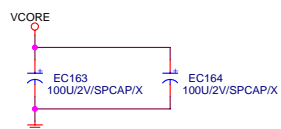
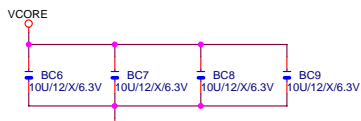
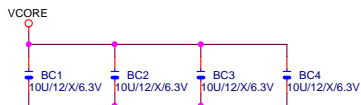

SP cap 料號: 10CL3-201000-11

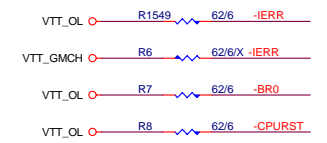
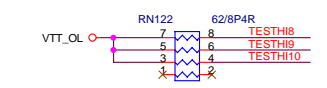
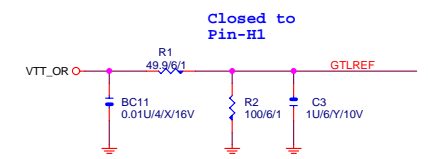
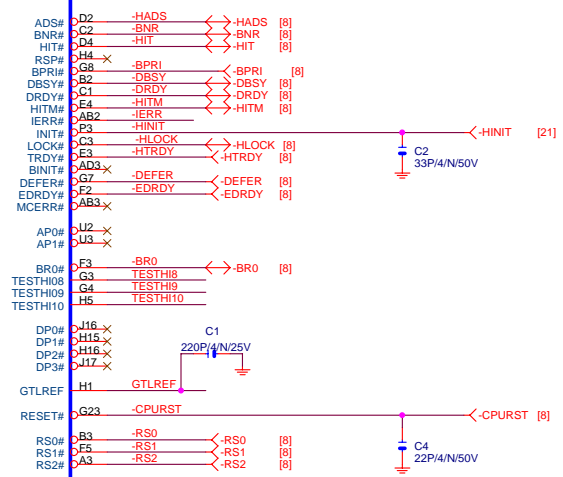
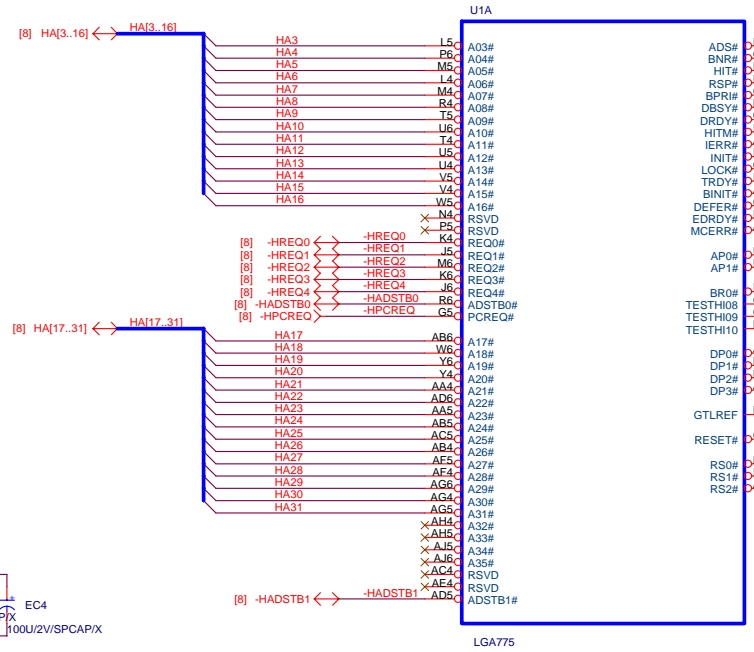
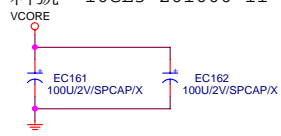

SP-CAP X 4PCS

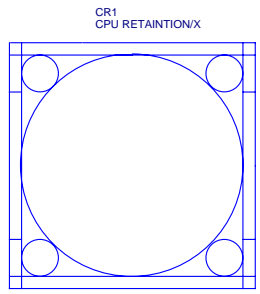
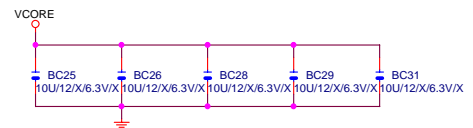
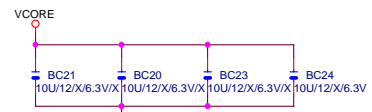
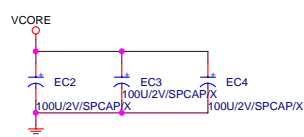

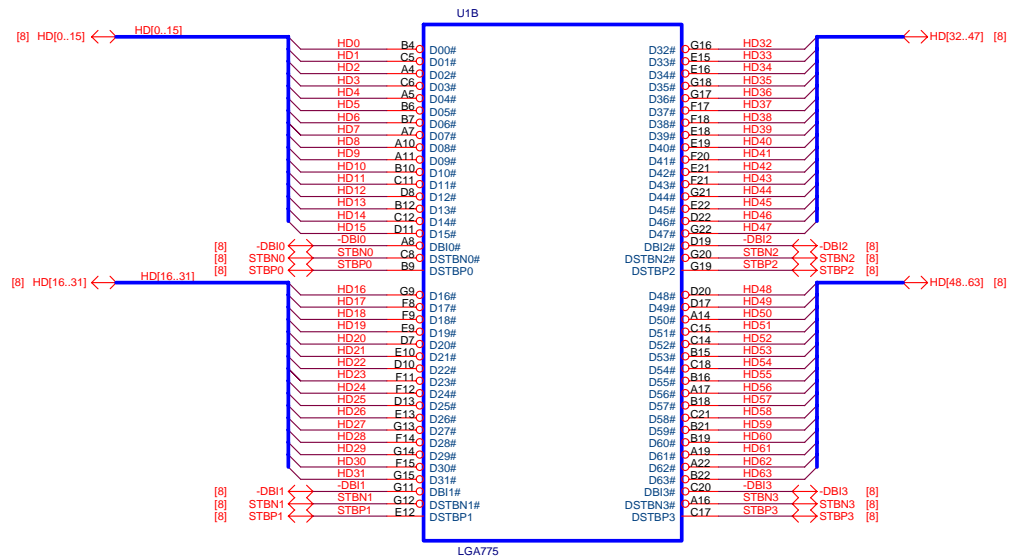

Note:
VCCA & VCOREPLL
define doesn't same as
old P4 design kit

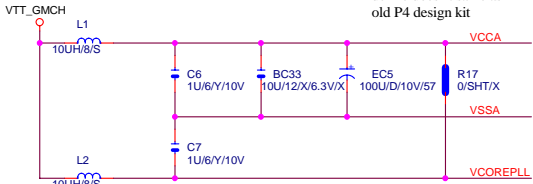

Trace width doesn't
less than 12 Mil

As close as possible to
CPU socket

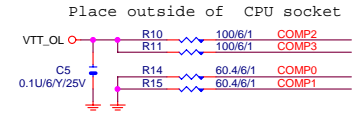

改排阻

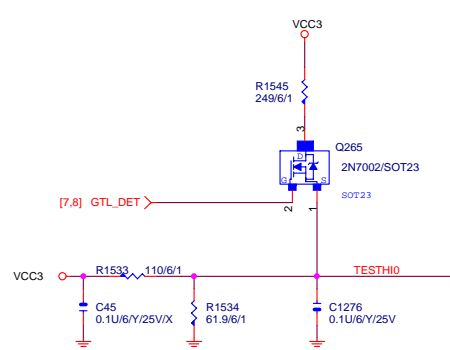
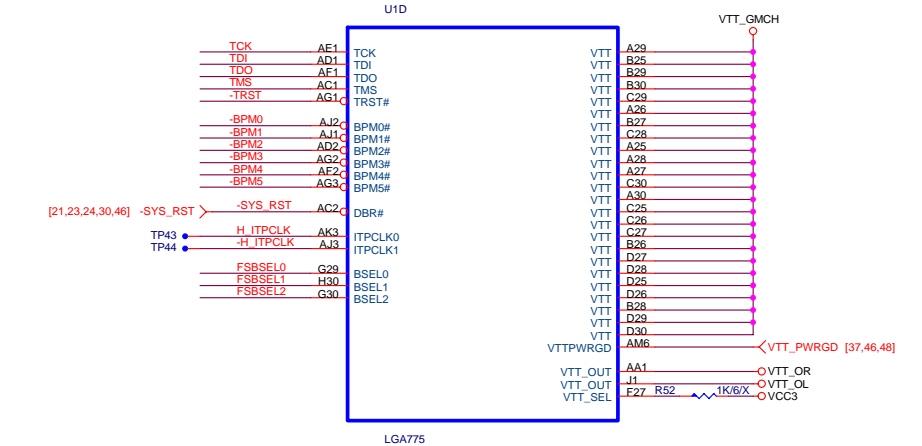
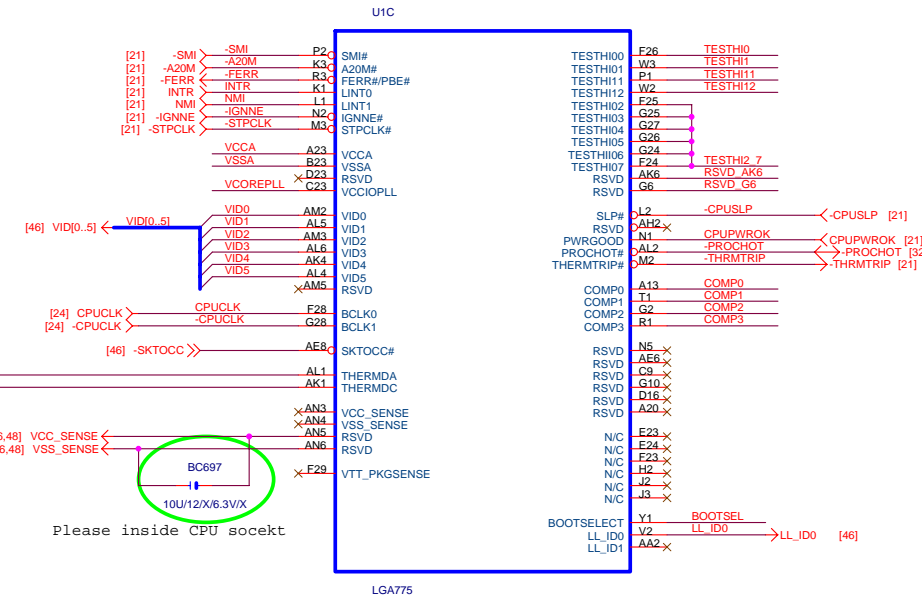
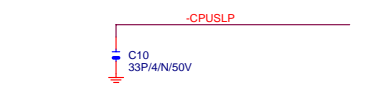
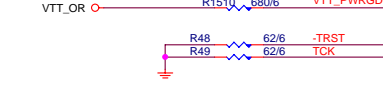
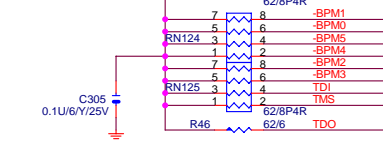
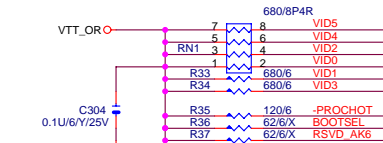
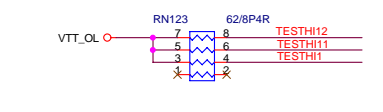
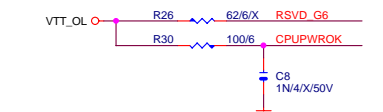
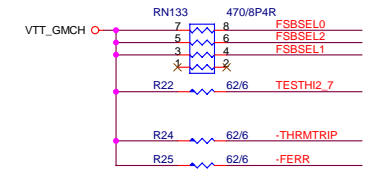

Please inside CPU socket

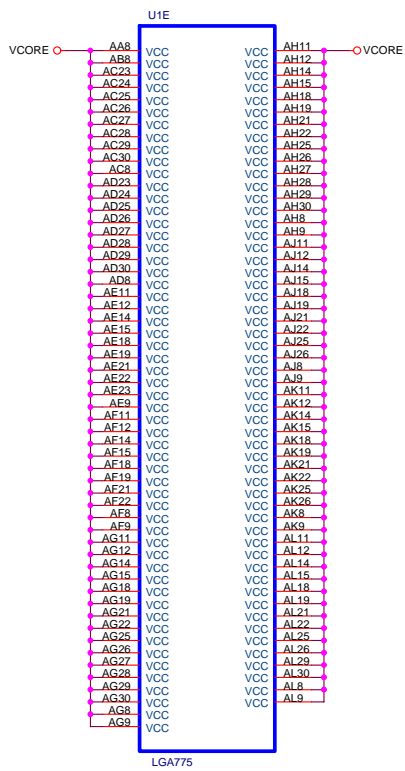

LGA775

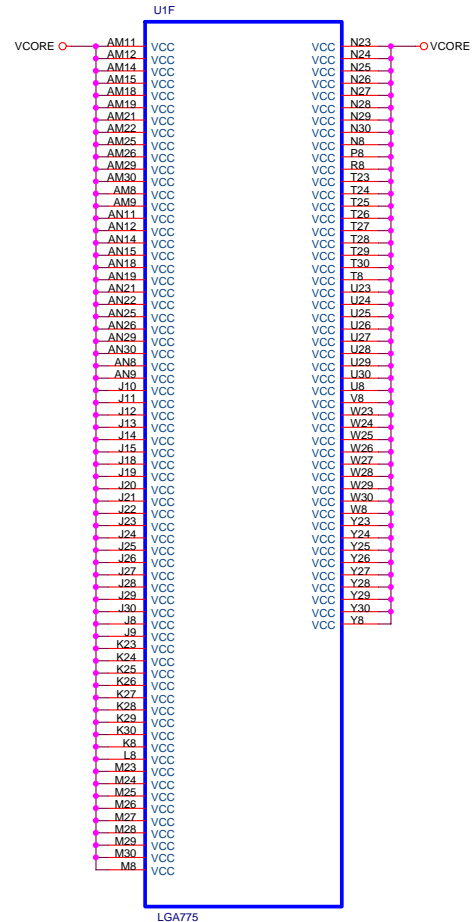

LGA775

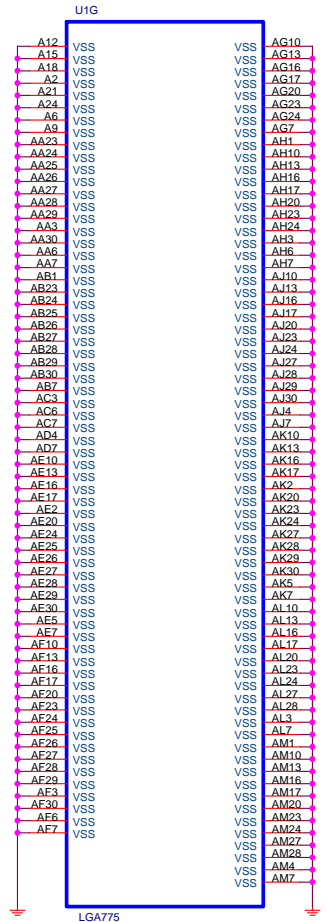

LGA775

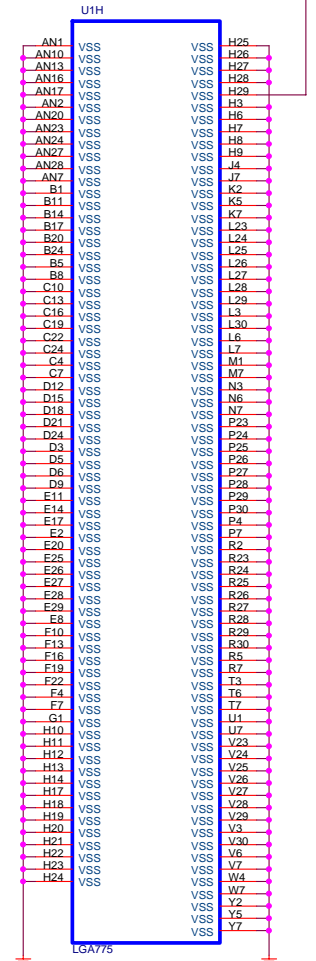

LGA775

[6,8] GTL_DET ←

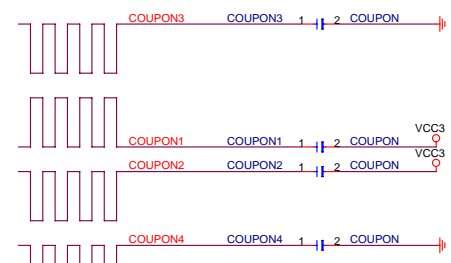
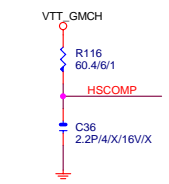
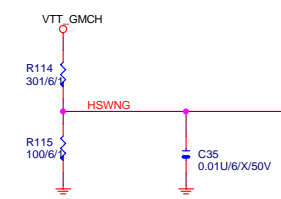
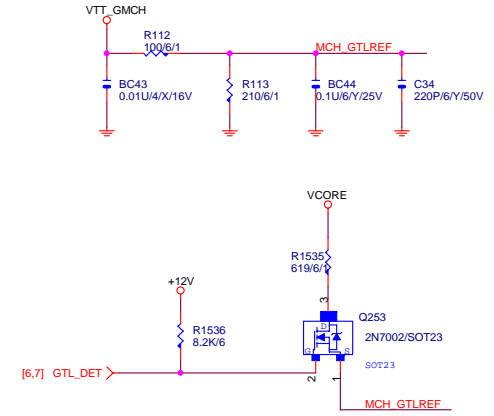
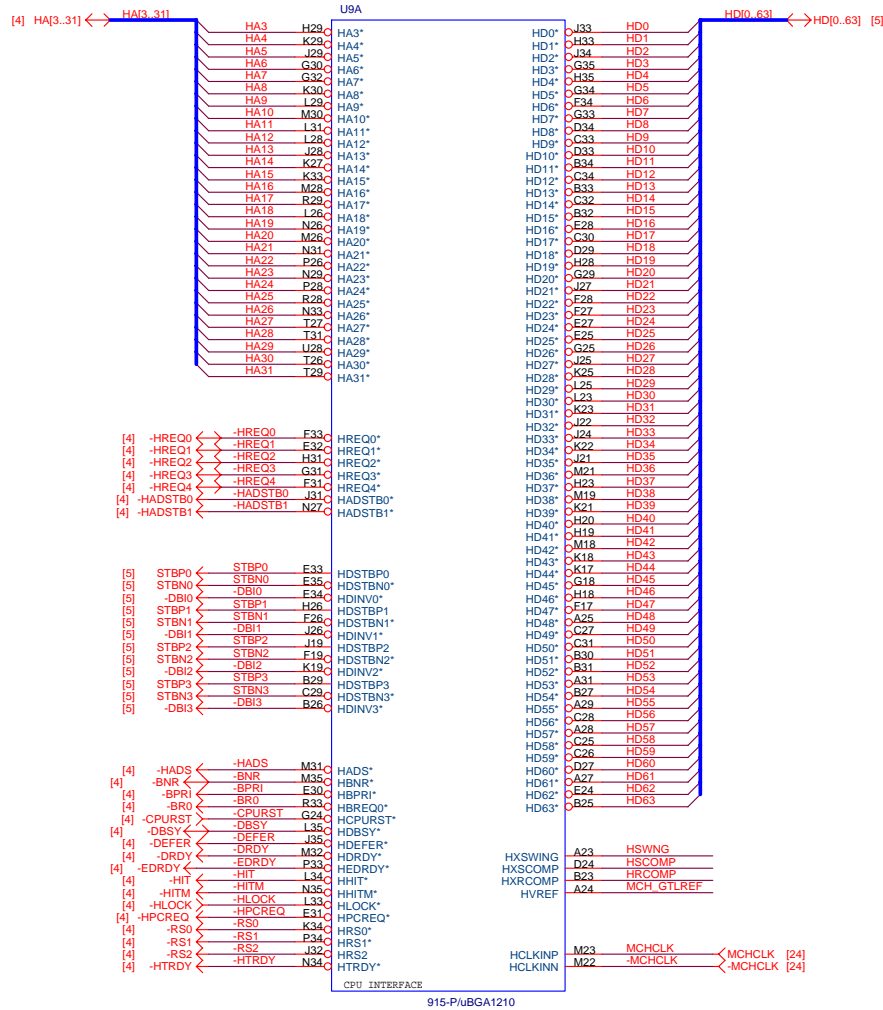

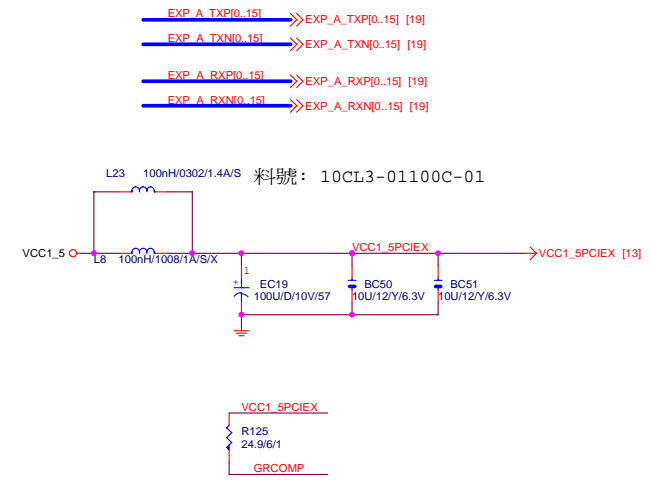
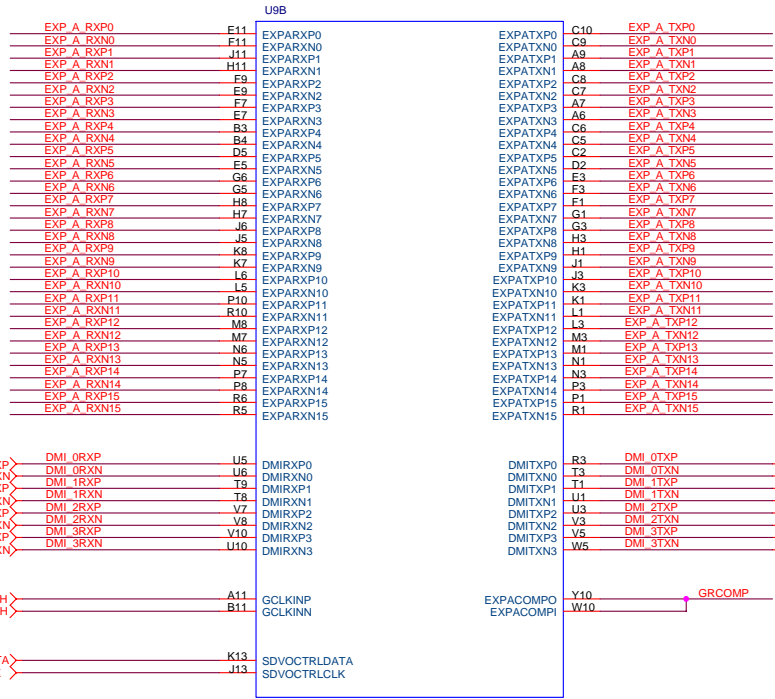

For DVO Function

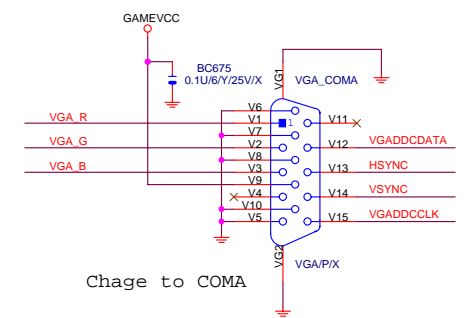
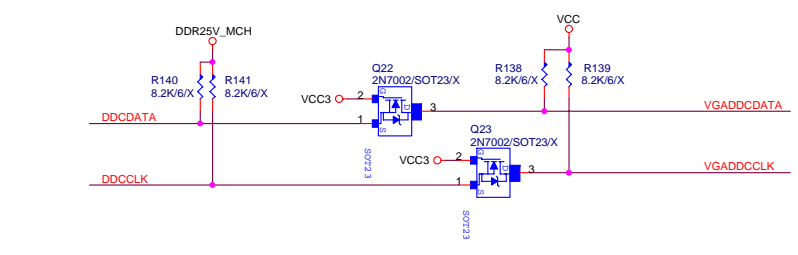
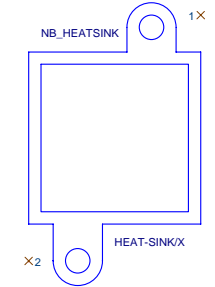
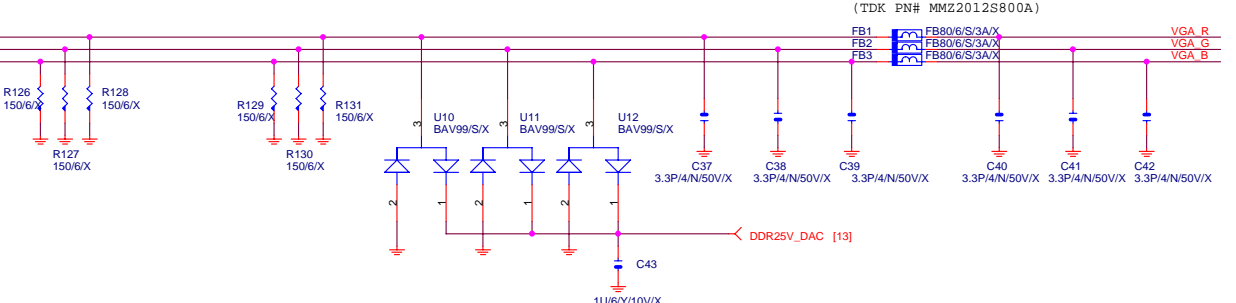
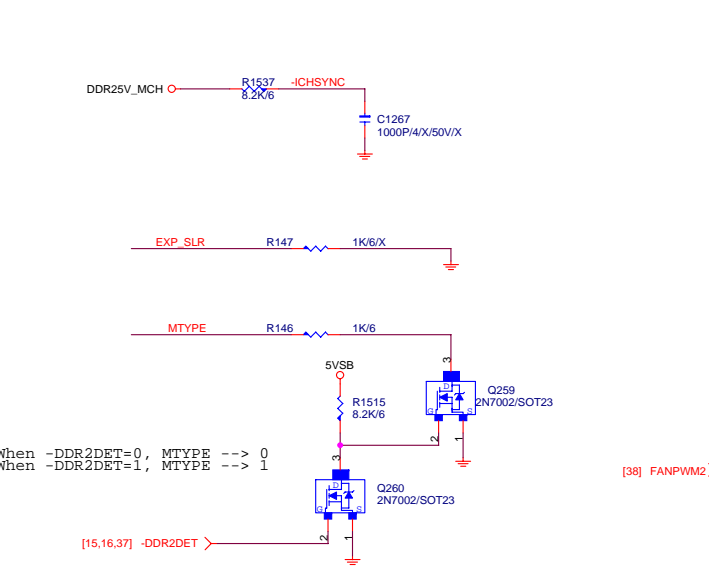
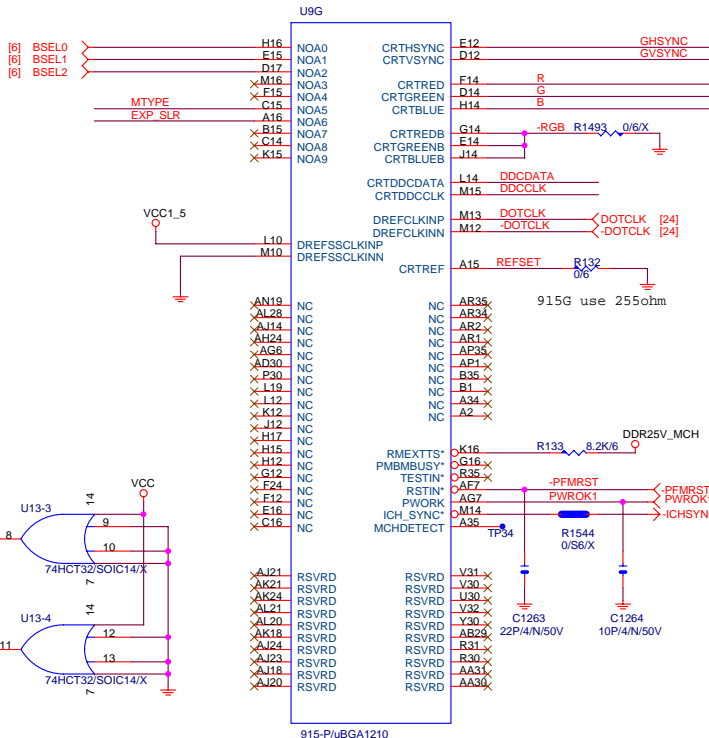
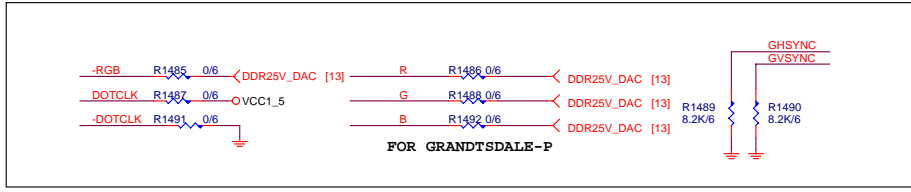

Intel Confidential		
Title GMCH-INTERNAL VGA		
Size Custom	Document Number	Rev 1.01
8GPNXP DUO		
Date: 星期四, 五月 20, 2004	Sheet 11	of 49

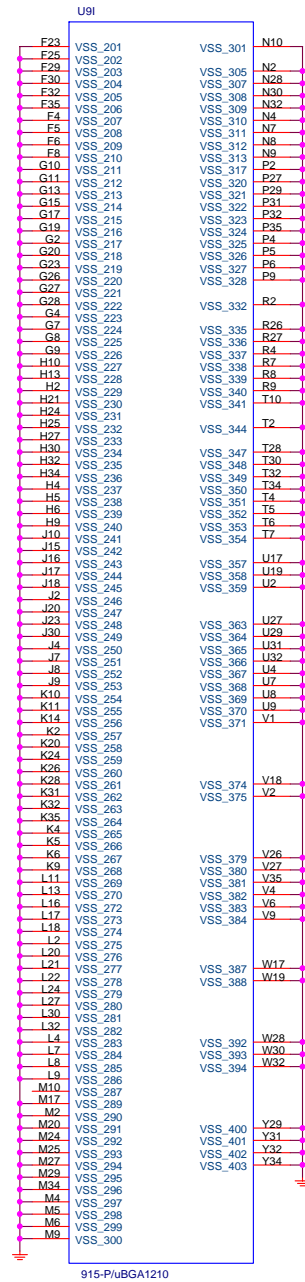
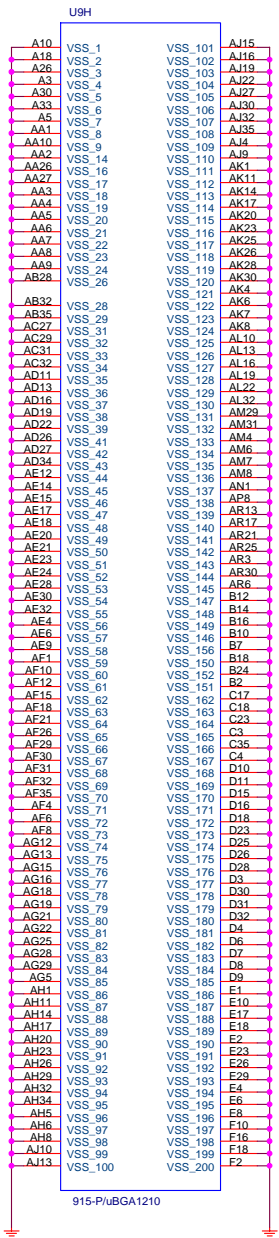

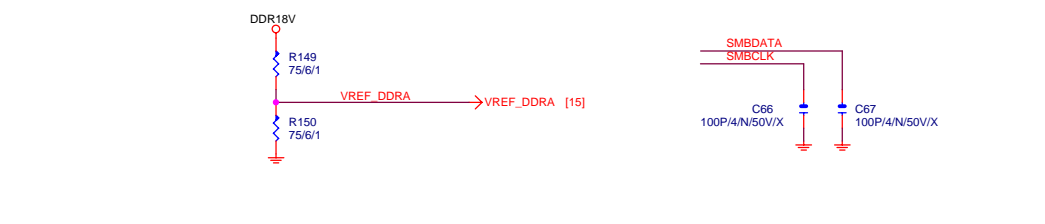
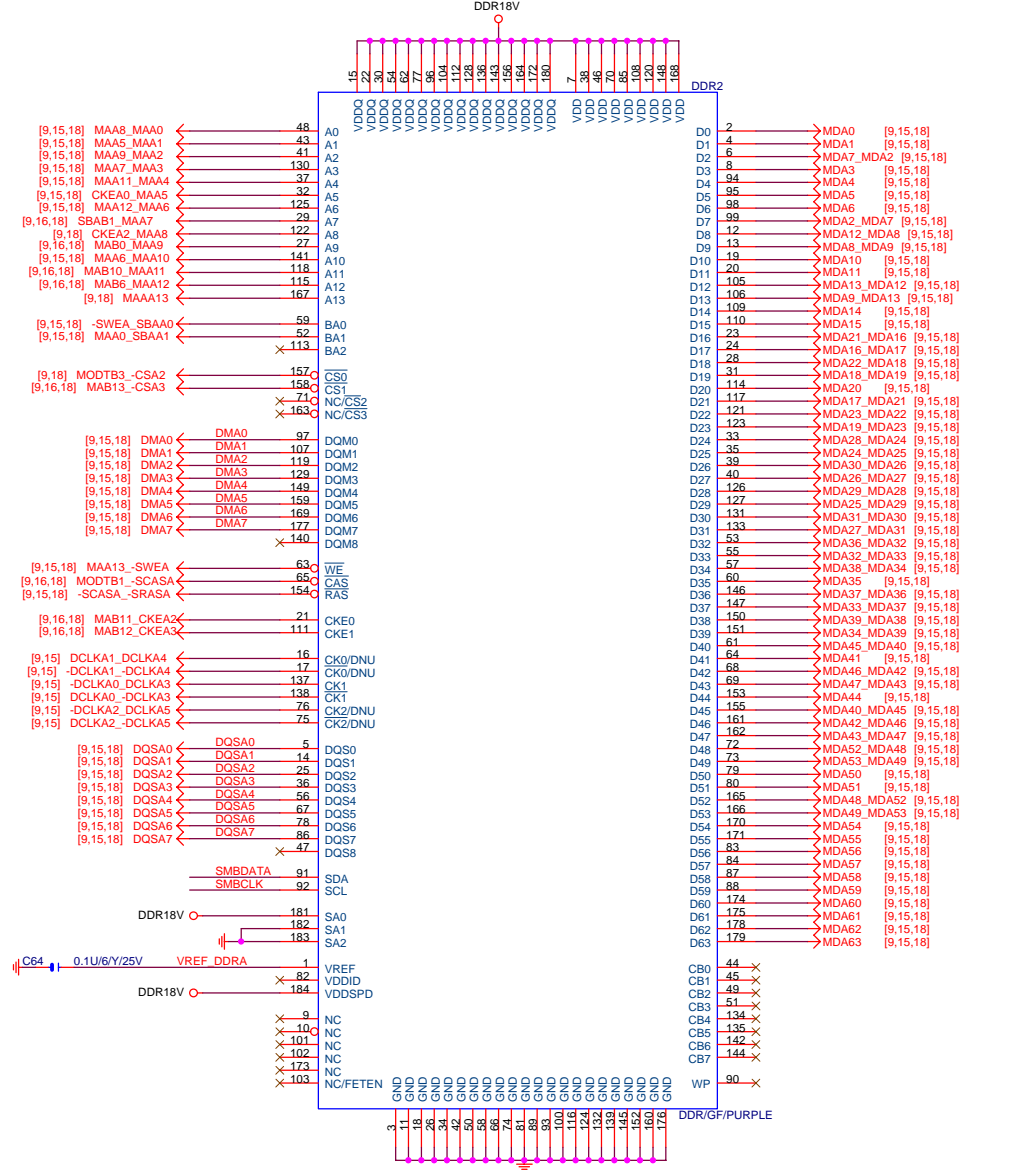
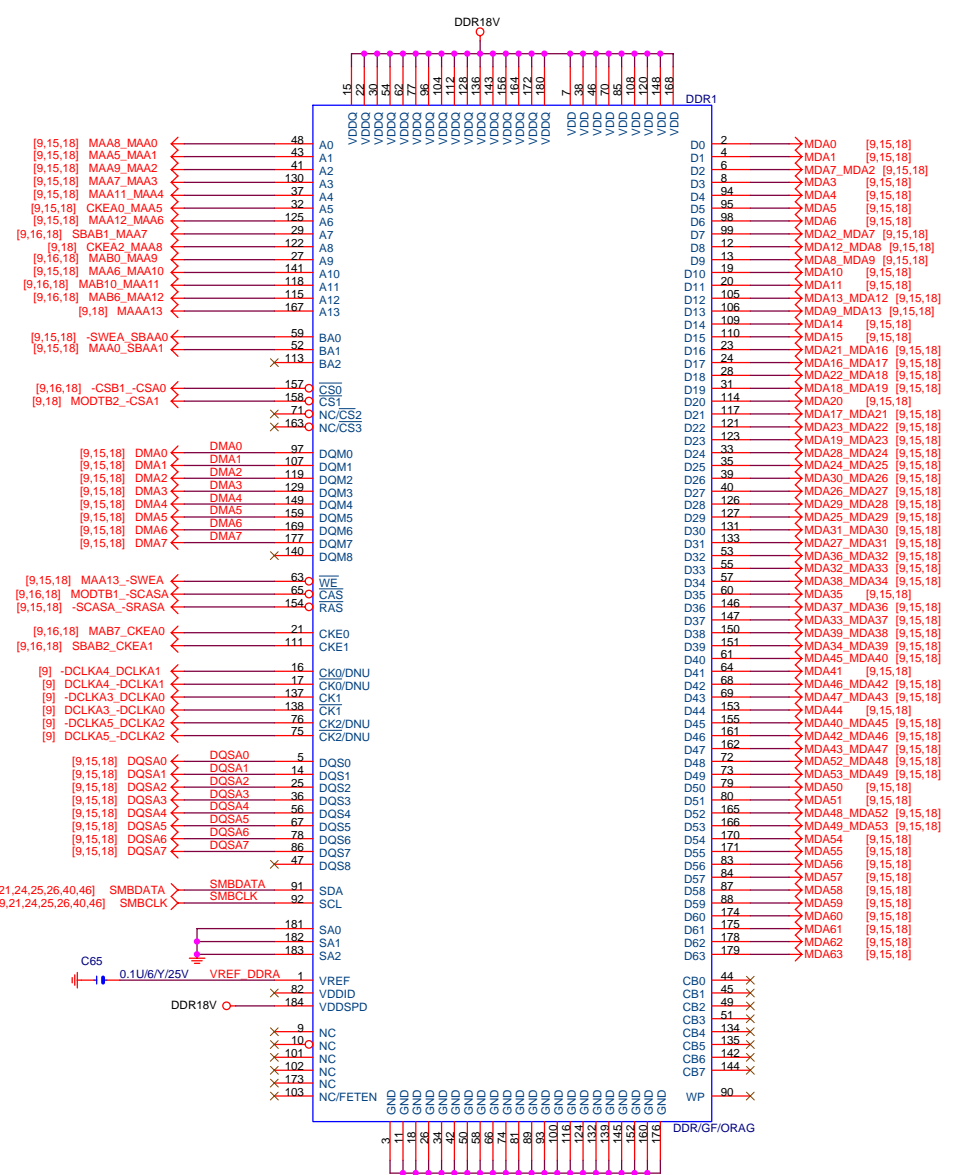

Intel Confidential

Title		
DDR1 CH A		
Size		Rev
8GPNXP DUO		1.01
Document Number	Date: 2004年5月20日	
Sheet	14 of 49	

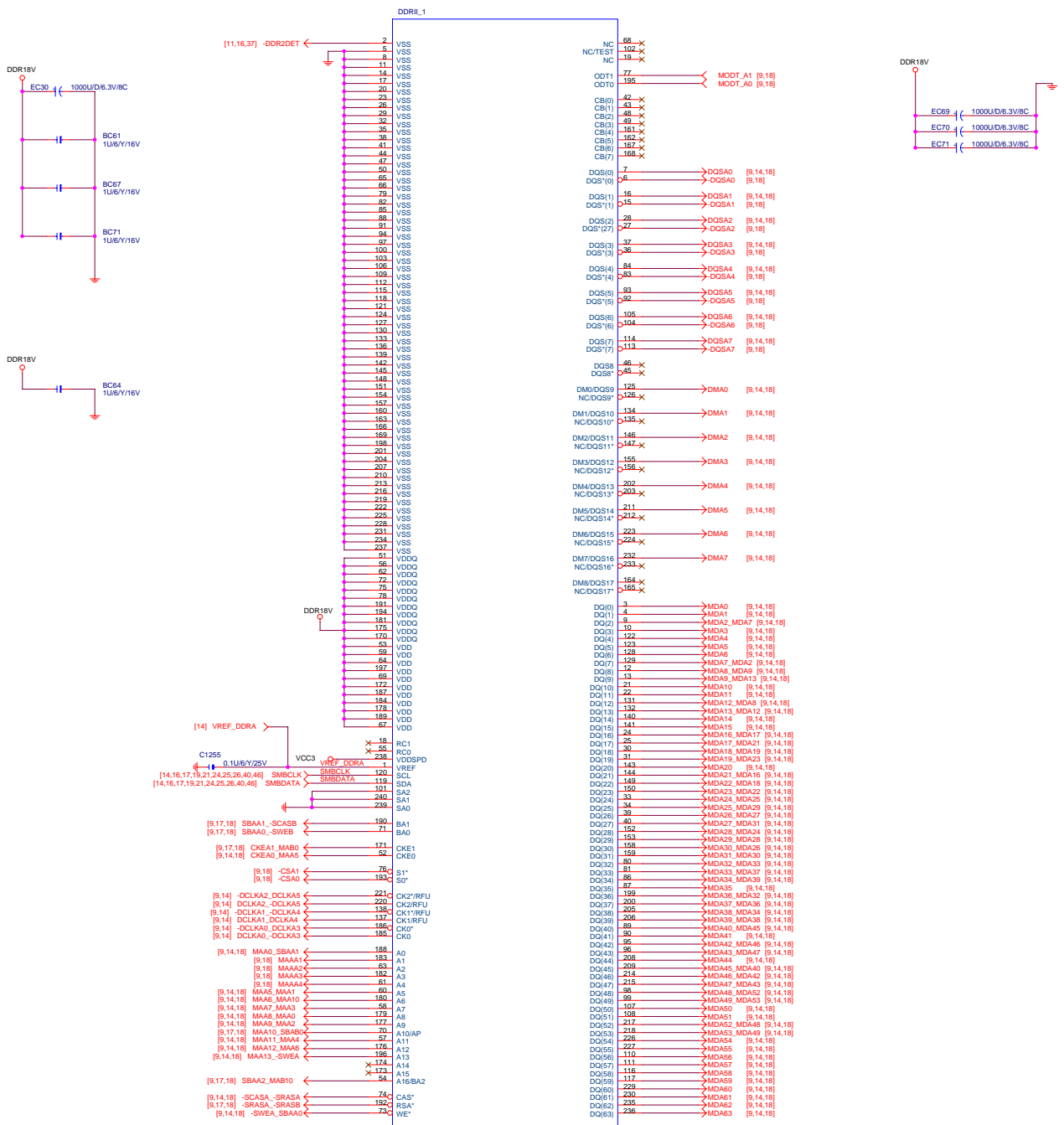

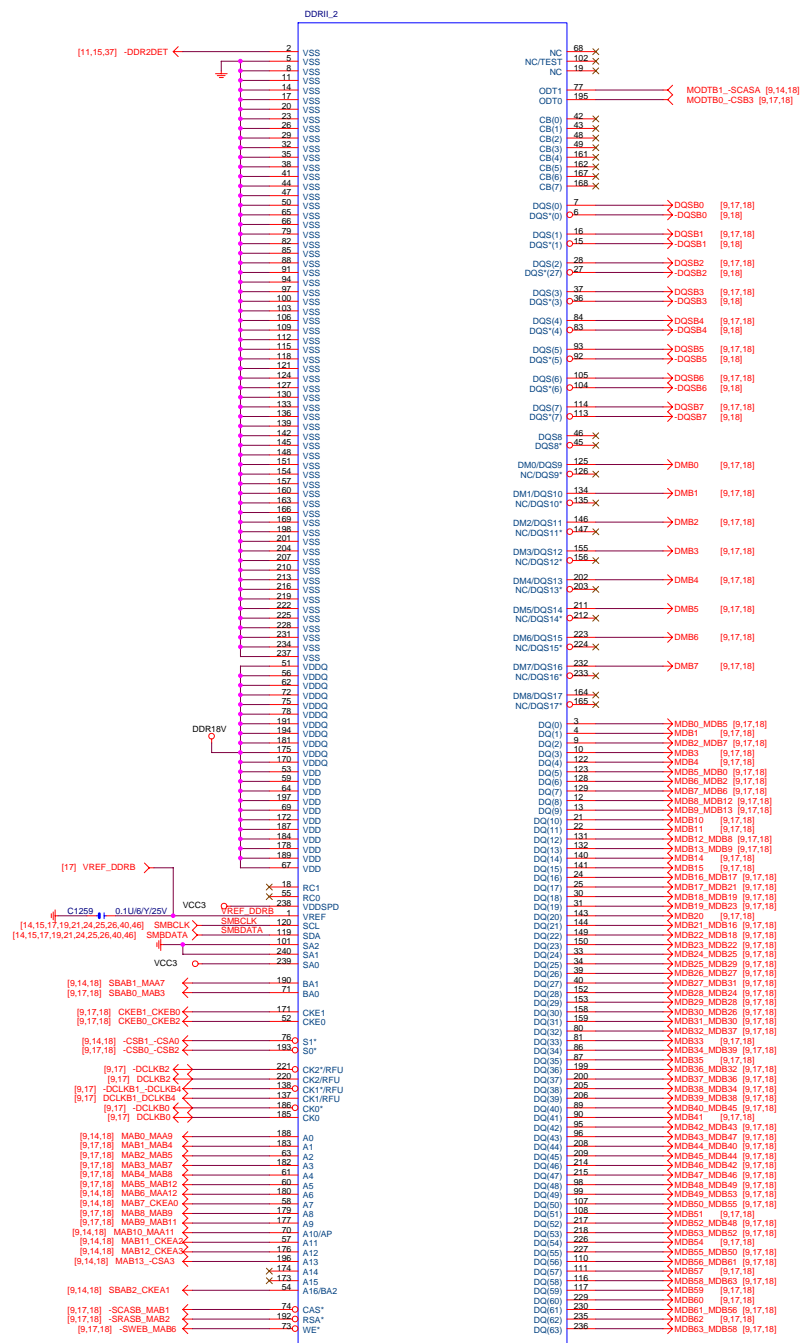

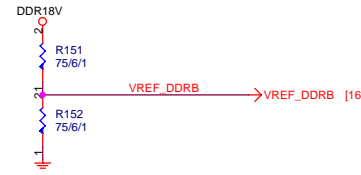
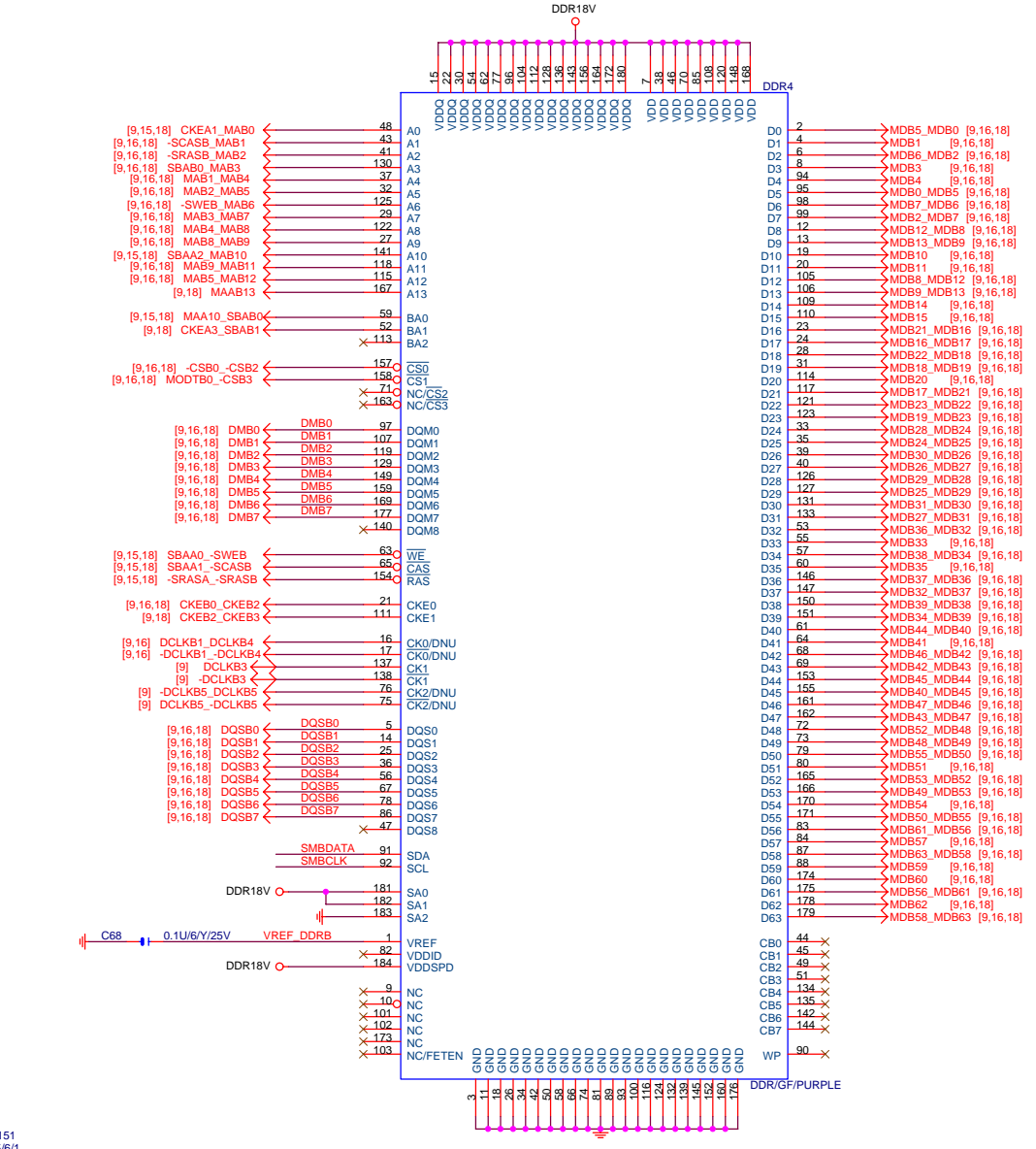
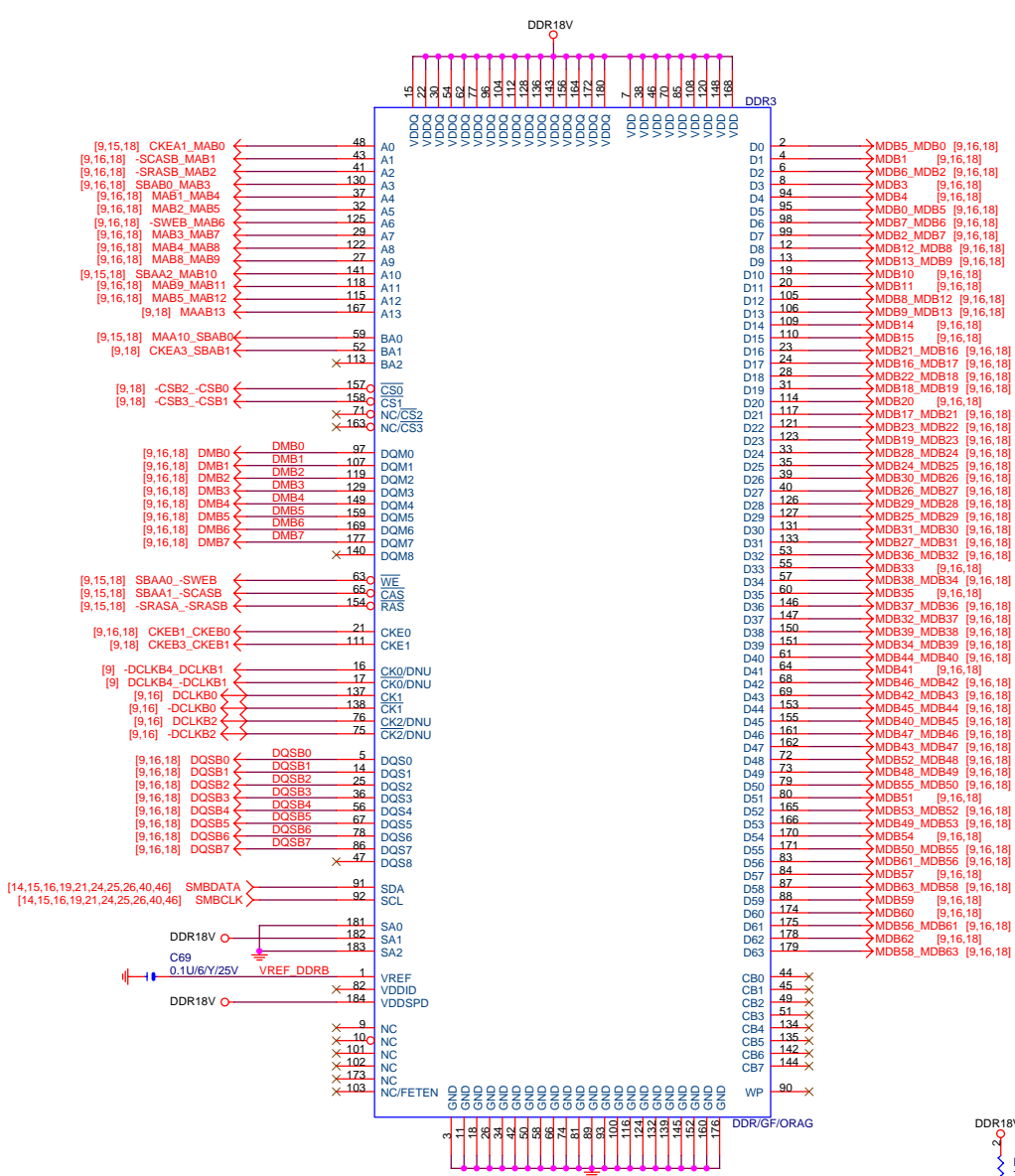

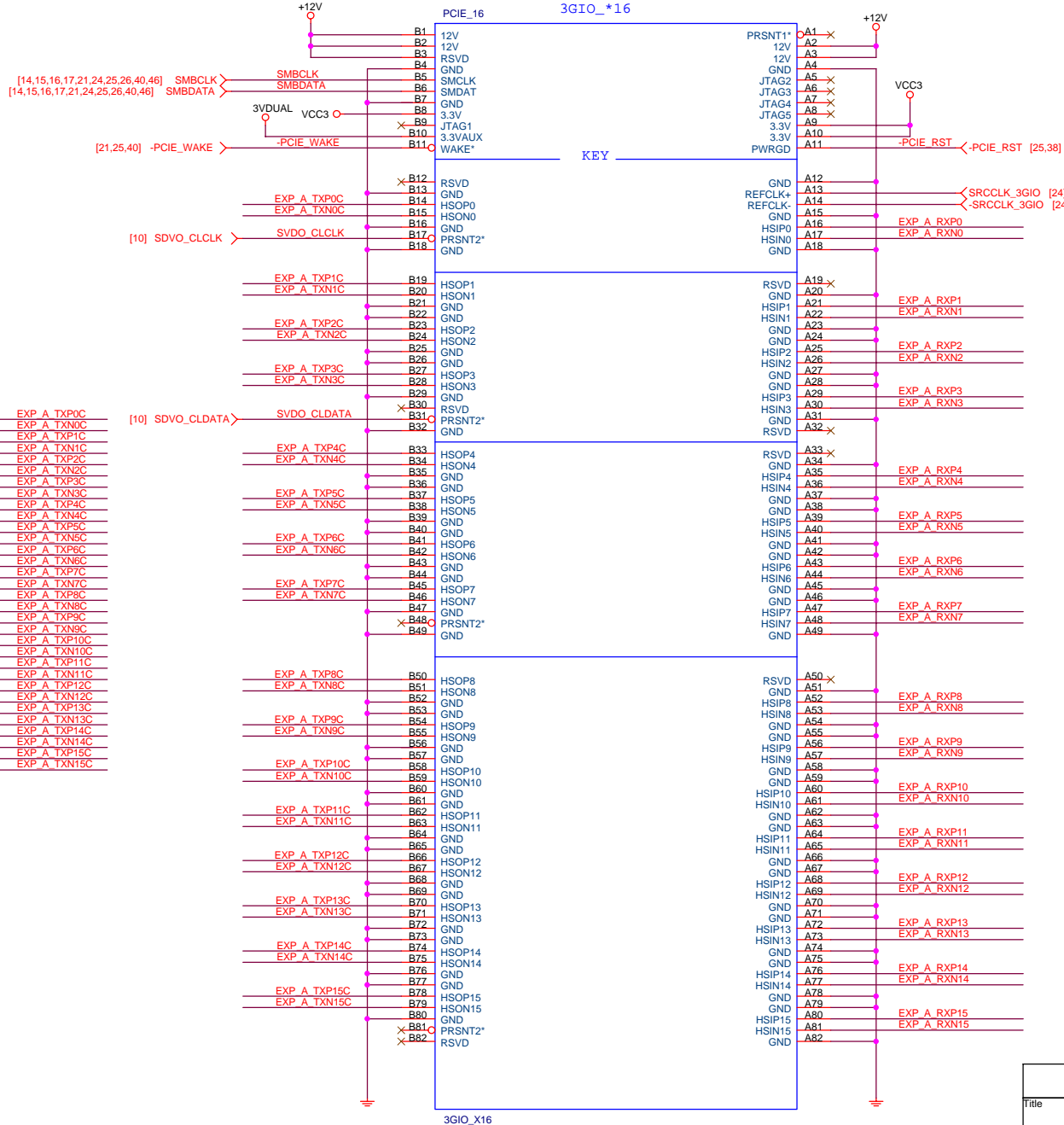
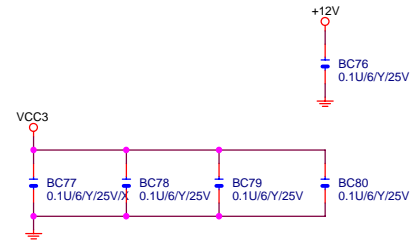

EXP_A_TXP[0..15] >>> EXP_A_TXP[0..15] [10]
 EXP_A_TXN[0..15] >>> EXP_A_TXN[0..15] [10]

EXP_A_TXP0	C70	0.1uF/6V/25V	EXP_A_TXP0C
EXP_A_TXN0	C71	0.1uF/6V/25V	EXP_A_TXN0C
EXP_A_TXP1	C72	0.1uF/6V/25V	EXP_A_TXP1C
EXP_A_TXN1	C73	0.1uF/6V/25V	EXP_A_TXN1C
EXP_A_TXP2	C74	0.1uF/6V/25V	EXP_A_TXP2C
EXP_A_TXN2	C75	0.1uF/6V/25V	EXP_A_TXN2C
EXP_A_TXP3	C76	0.1uF/6V/25V	EXP_A_TXP3C
EXP_A_TXN3	C77	0.1uF/6V/25V	EXP_A_TXN3C
EXP_A_TXP4	C78	0.1uF/6V/25V	EXP_A_TXP4C
EXP_A_TXN4	C79	0.1uF/6V/25V	EXP_A_TXN4C
EXP_A_TXP5	C80	0.1uF/6V/25V	EXP_A_TXP5C
EXP_A_TXN5	C81	0.1uF/6V/25V	EXP_A_TXN5C
EXP_A_TXP6	C82	0.1uF/6V/25V	EXP_A_TXP6C
EXP_A_TXN6	C83	0.1uF/6V/25V	EXP_A_TXN6C
EXP_A_TXP7	C84	0.1uF/6V/25V	EXP_A_TXP7C
EXP_A_TXN7	C85	0.1uF/6V/25V	EXP_A_TXN7C
EXP_A_TXP8	C86	0.1uF/6V/25V	EXP_A_TXP8C
EXP_A_TXN8	C87	0.1uF/6V/25V	EXP_A_TXN8C
EXP_A_TXP9	C88	0.1uF/6V/25V	EXP_A_TXP9C
EXP_A_TXN9	C89	0.1uF/6V/25V	EXP_A_TXN9C
EXP_A_TXP10	C90	0.1uF/6V/25V	EXP_A_TXP10C
EXP_A_TXN10	C91	0.1uF/6V/25V	EXP_A_TXN10C
EXP_A_TXP11	C92	0.1uF/6V/25V	EXP_A_TXP11C
EXP_A_TXN11	C93	0.1uF/6V/25V	EXP_A_TXN11C
EXP_A_TXP12	C94	0.1uF/6V/25V	EXP_A_TXP12C
EXP_A_TXN12	C95	0.1uF/6V/25V	EXP_A_TXN12C
EXP_A_TXP13	C96	0.1uF/6V/25V	EXP_A_TXP13C
EXP_A_TXN13	C97	0.1uF/6V/25V	EXP_A_TXN13C
EXP_A_TXP14	C98	0.1uF/6V/25V	EXP_A_TXP14C
EXP_A_TXN14	C99	0.1uF/6V/25V	EXP_A_TXN14C
EXP_A_TXP15	C100	0.1uF/6V/25V	EXP_A_TXP15C
EXP_A_TXN15	C101	0.1uF/6V/25V	EXP_A_TXN15C

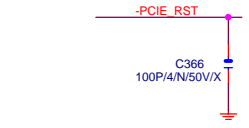

EXP_A_RXP[0..15] >>> EXP_A_RXP[0..15] [10]
 EXP_A_RXN[0..15] >>> EXP_A_RXN[0..15] [10]

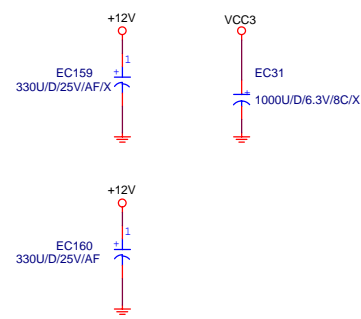

DMI Connection Note
 GMCH TX Pin Need Connect to ICH6 RX Pin
 ICH6 TX Pin Need Connect to GMCH RX Pin

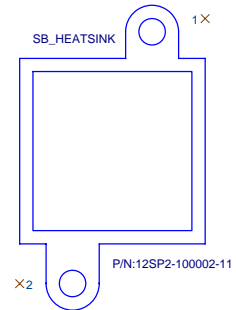
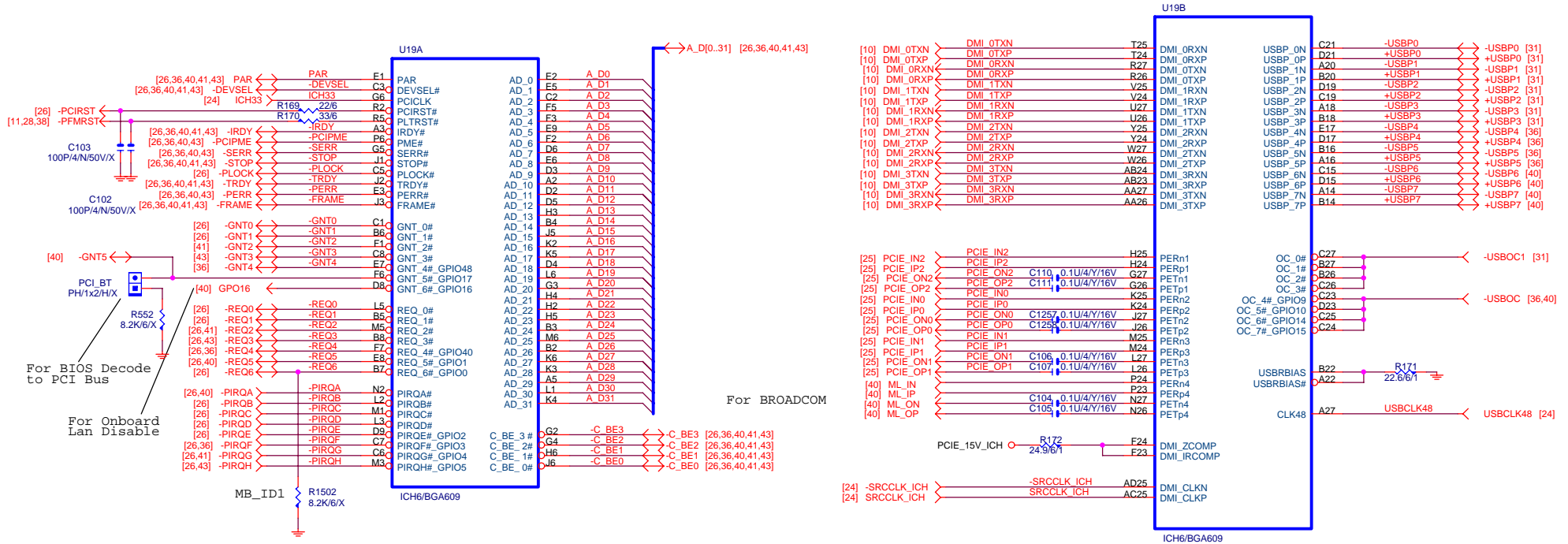

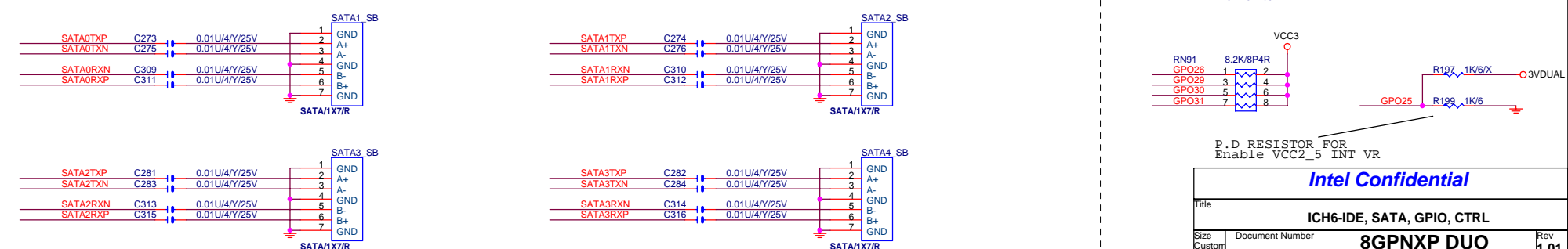
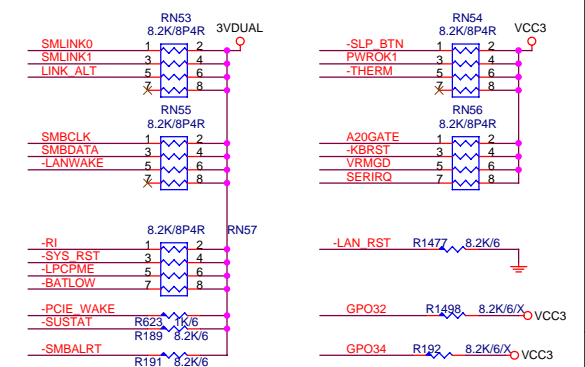
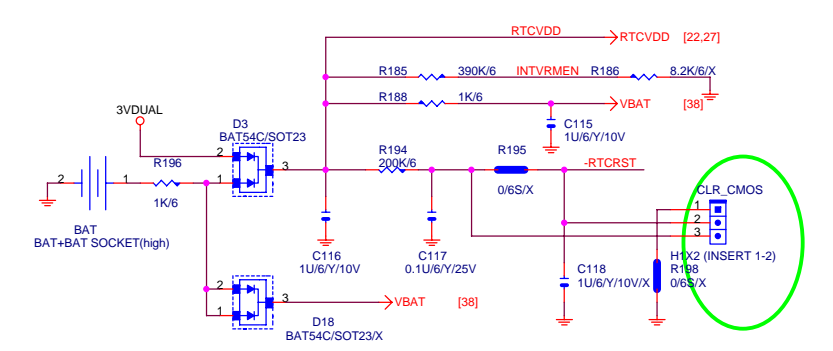
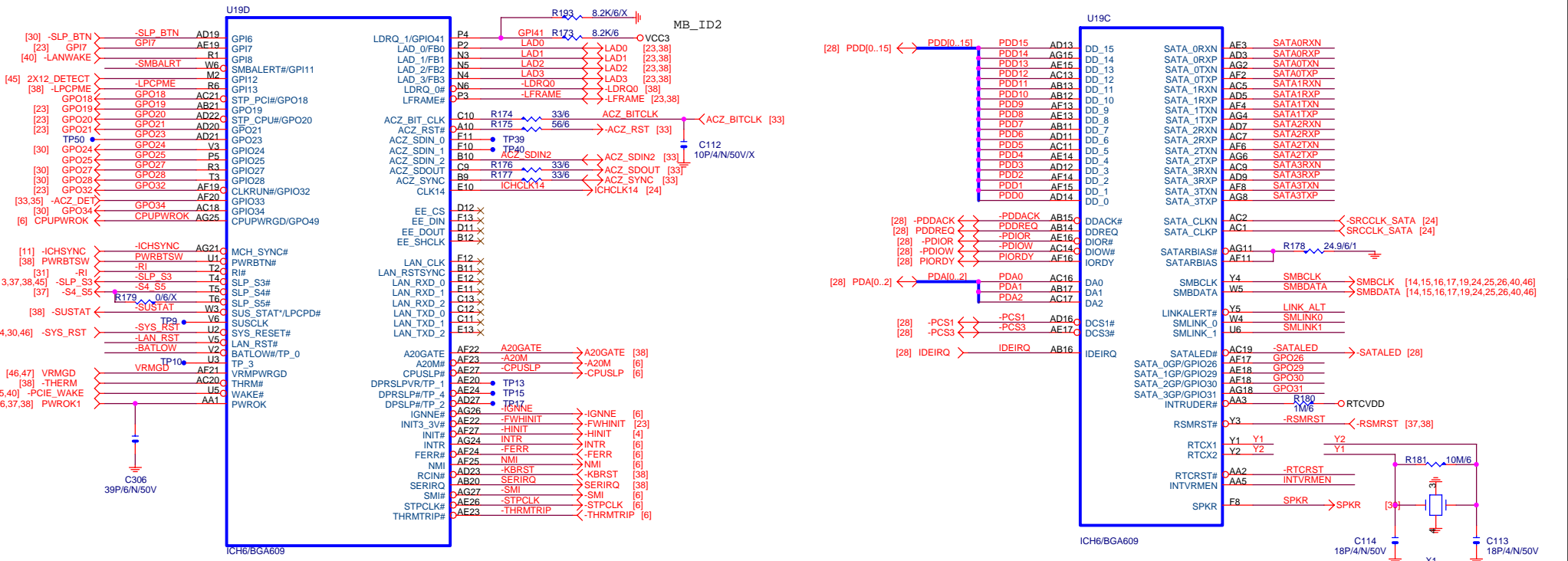

P.D RESISTOR FOR Enable VCC2_5 INTL VR

Intel Confidential

Title: ICH6-IDE, SATA, GPIO, CTRL

Size: 8GPNXP DUO

Rev: 1.01

Date: 星期四, 五月 20, 2004

Sheet: 21 of 49

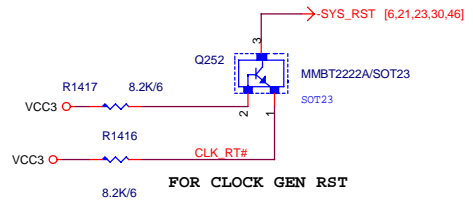
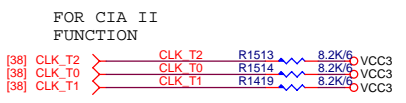
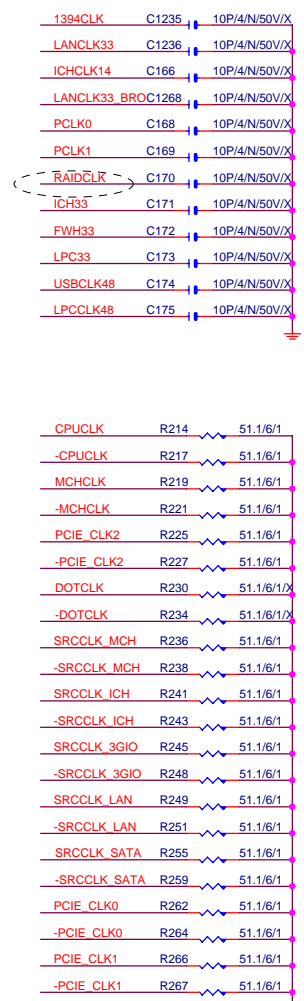
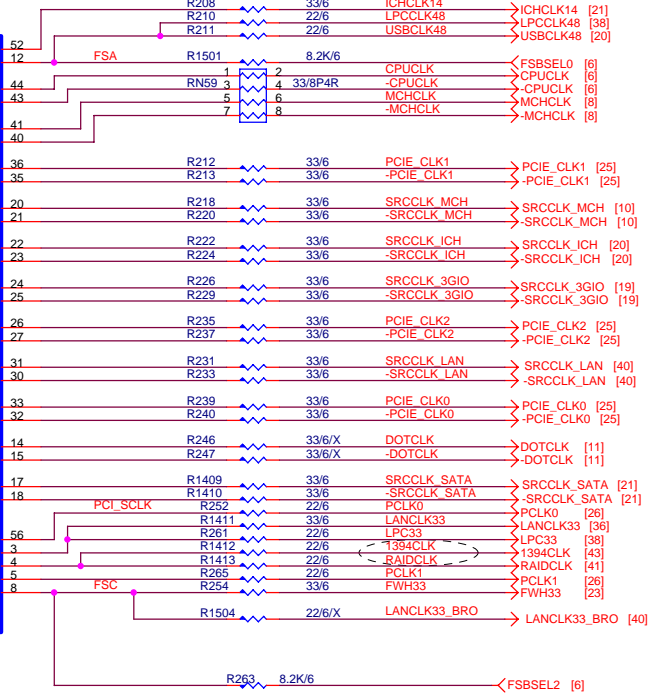
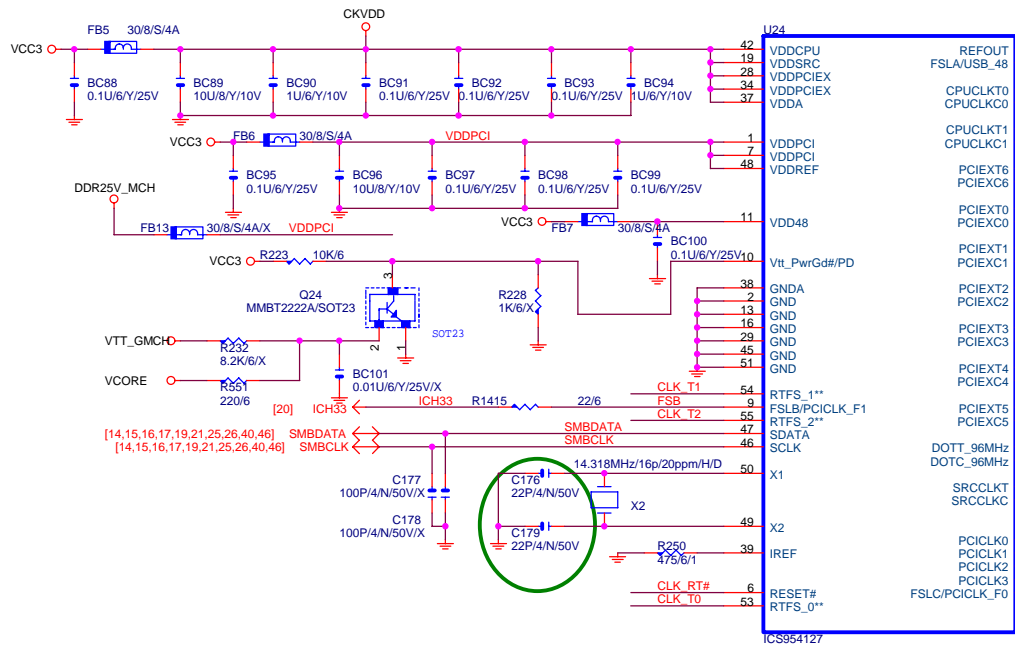

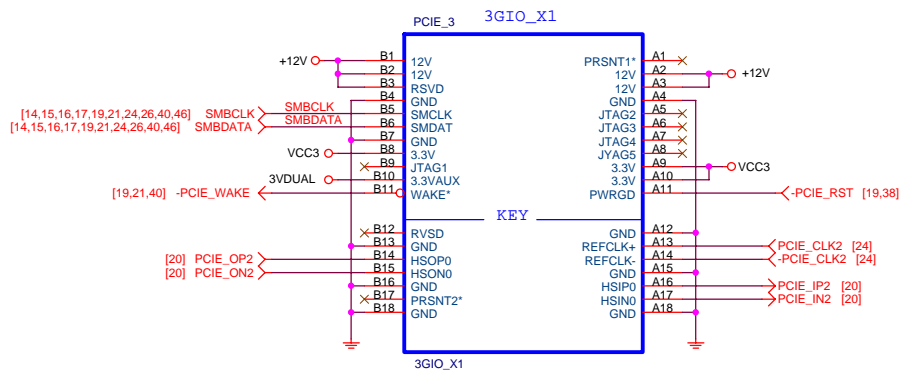
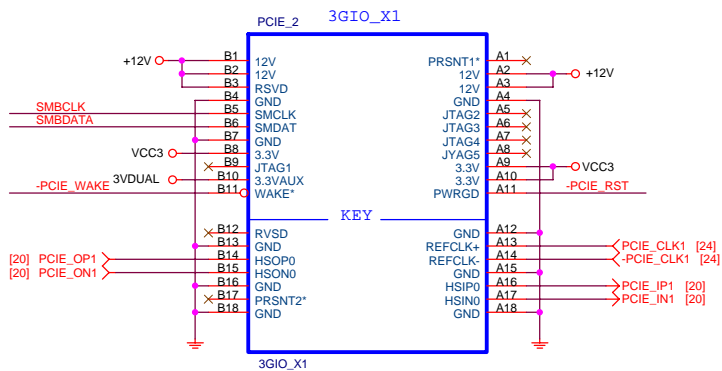
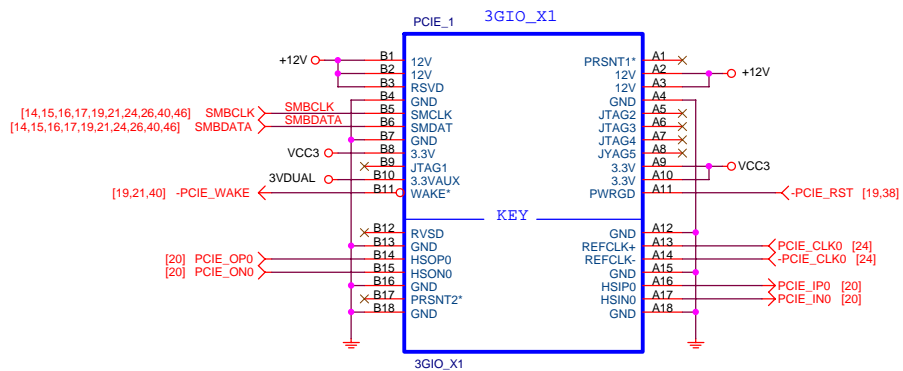

Intel Confidential

Title		PCI E SLOT 1, 2, 3	
Size		8GPNXP DUO	
Document Number		Rev 1.01	
Date:	星期四, 五月 20, 2004	Sheet	25 of 49

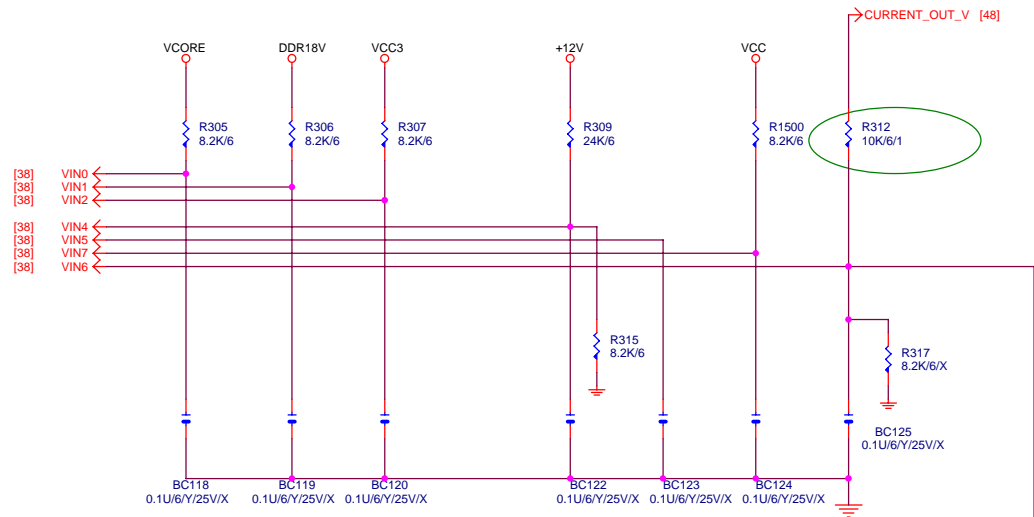
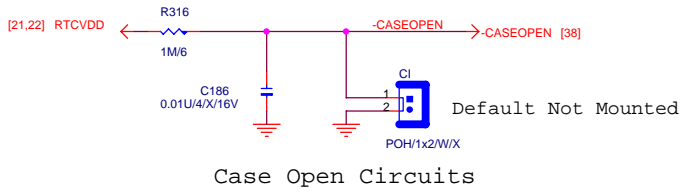
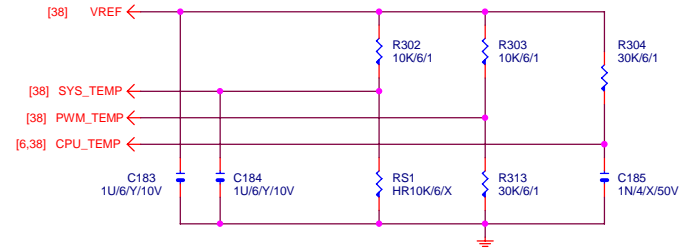

For dual power

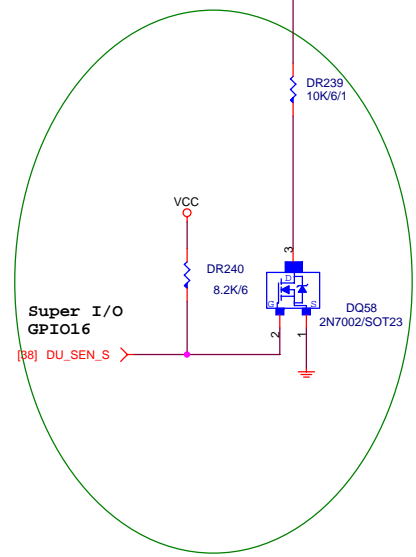

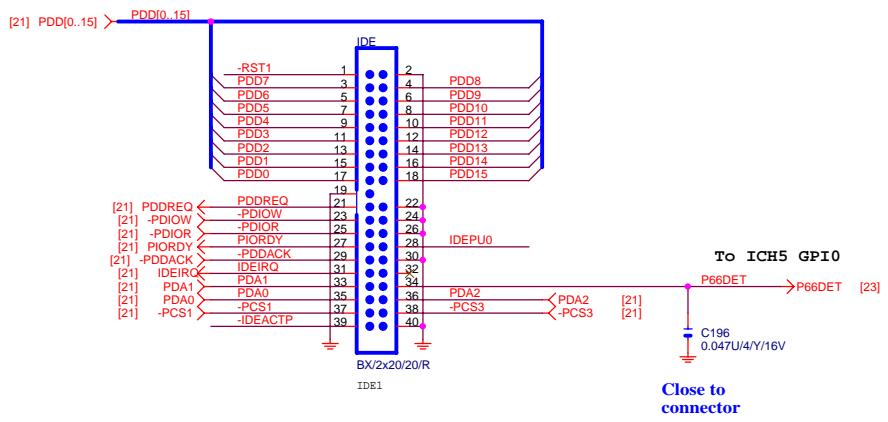
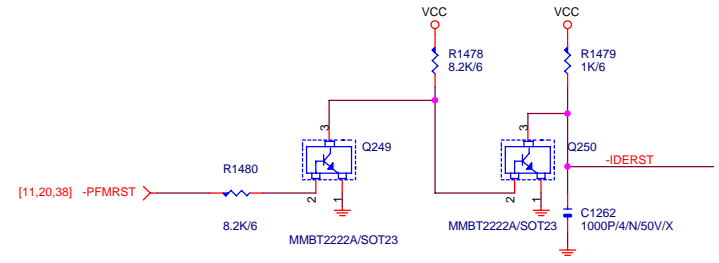
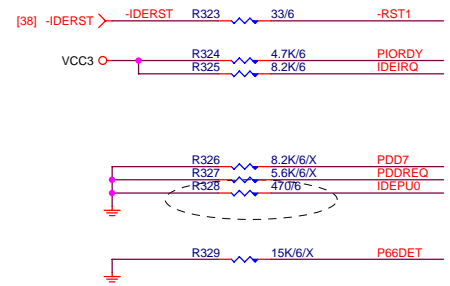
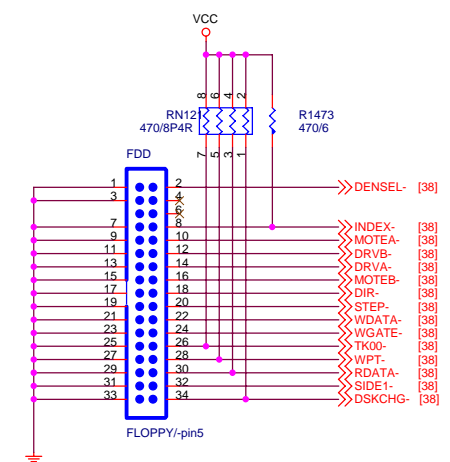
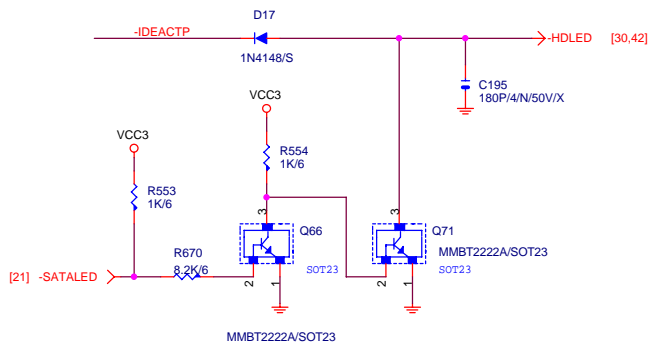

PRIMARY IDE CONNECTOR

Intel Confidential

Title			IDE		
Size			Document Number		
B			8GPNXP DUO		
Date:			Rev		
星期四, 五月 20, 2004			1.01		
Sheet		28		of 49	

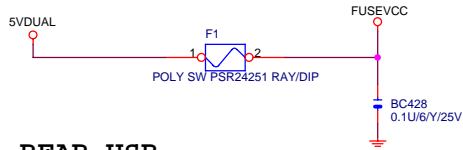

REAR_USB

1-2 Enable USB Wake Up
2-3 Disable USB Wake Up

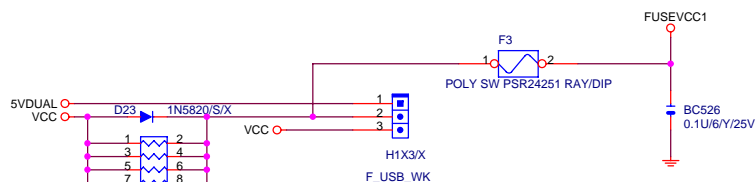

FRONT_USB

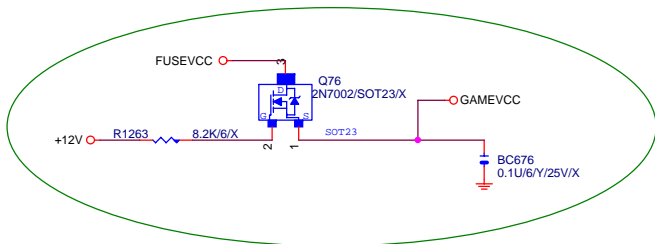

Remove Game Port

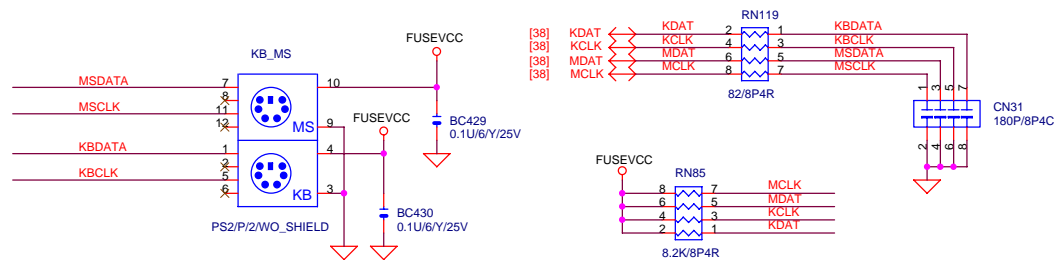
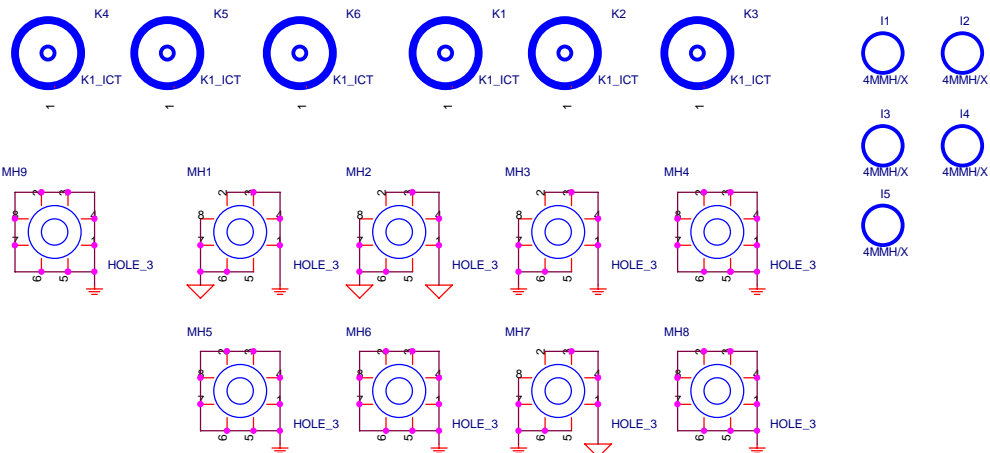

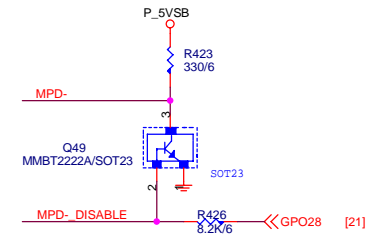
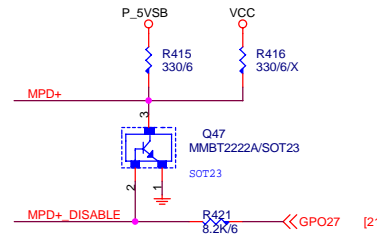
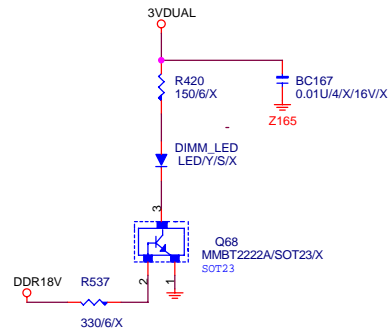
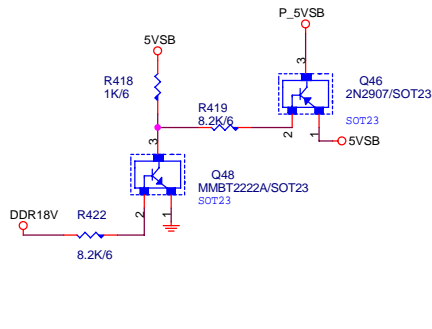

INTEL FRONT PANEL

3 PIN POWER LED
LAYOUT PLACE CLOSE
TO F_PANEL

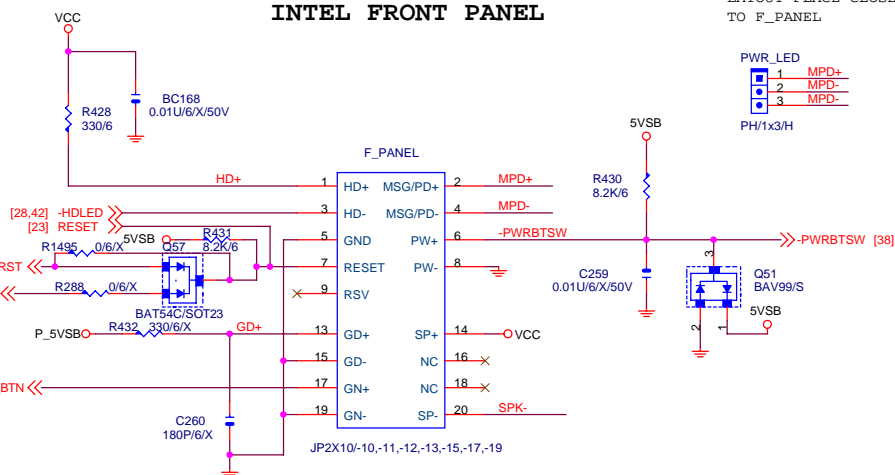
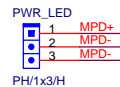

PREVENT S0 W/O CPU, GREEN IS ON.

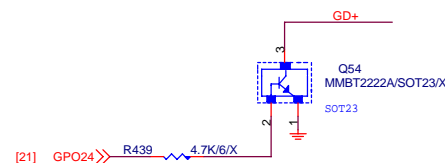
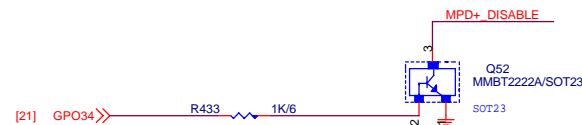

BUZZER

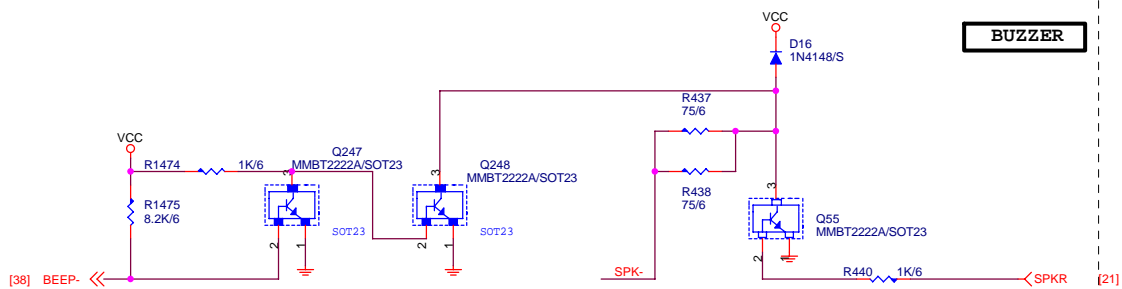

Intel Confidential		
FRONT PANEL		
8GPNXP DUO		
Size Custom	Document Number	Rev 1.01
Date: 星期四, 五月 20, 2004	Sheet 30 of 49	

FRONT USB

ICH5 USB2.0

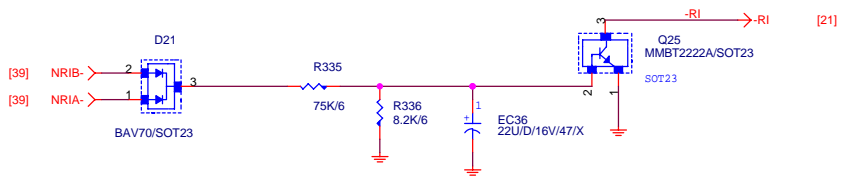
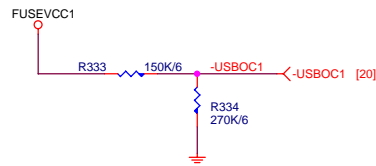
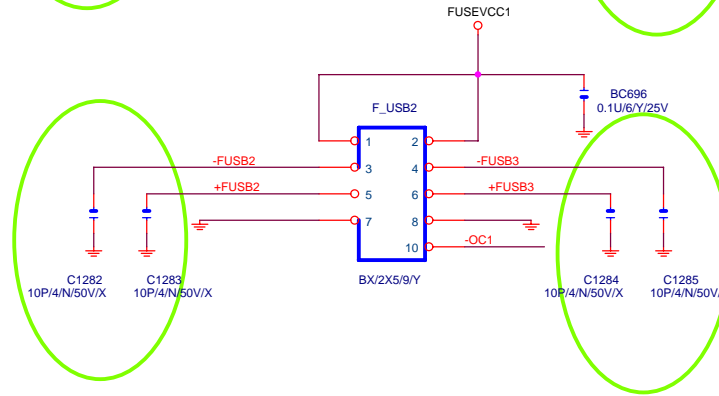
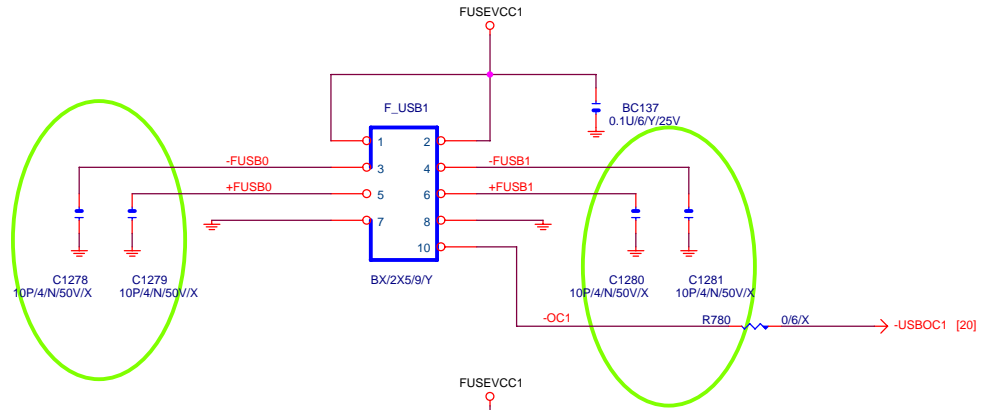
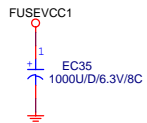
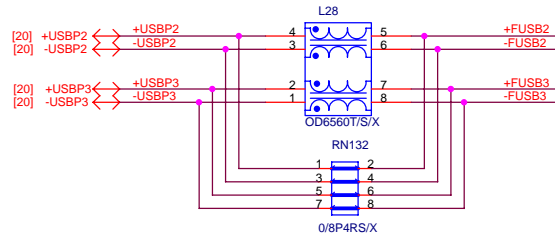
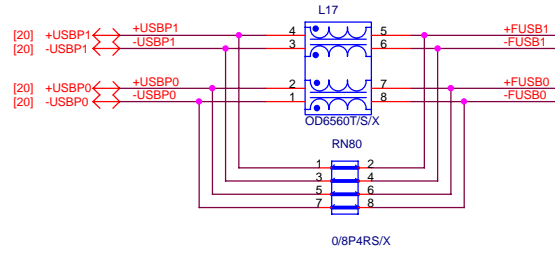

Intel Confidential			
FRONT USB CONNECTOR			
8GPNXP DUO			
Size B	Document Number	Rev 1.01	
Date:	星期四, 五月 20, 2004	Sheet 31 of 49	

KA393改為LM358，電源pin改接+12V，Prochot#溫度需重新調整之。

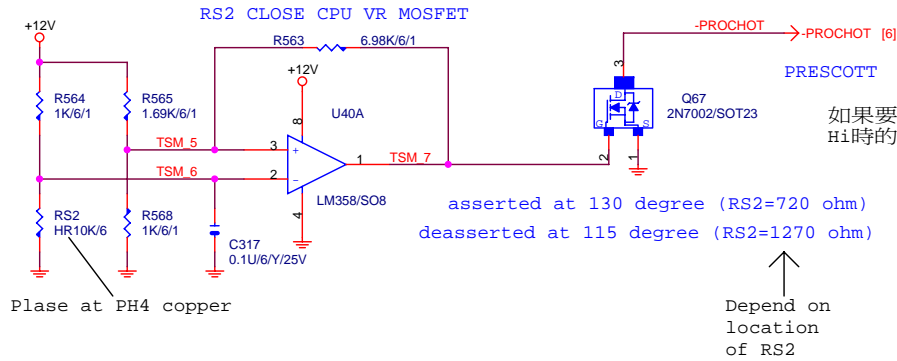

如果要用2N7002需注意OP output Hi時的電壓是否遠大於2V。

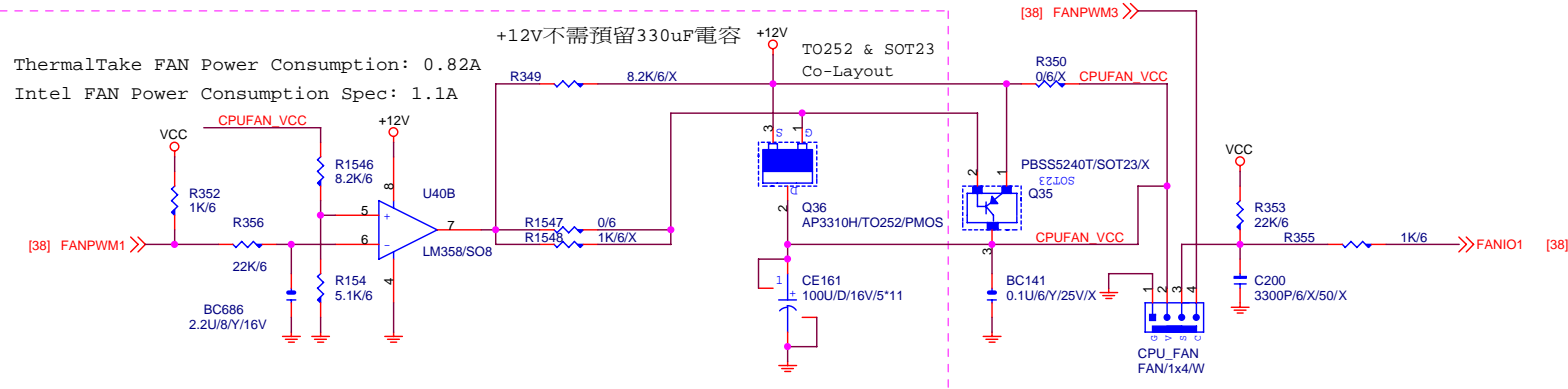
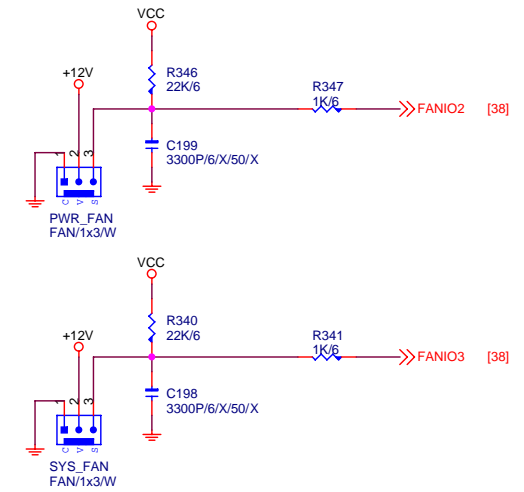

改為Foot Print 可與3PIN FAN 的Library
料號: 11NH5-020104-41

If use PBSS5240 1pcs : (non airflow)

CPUFAN_VCC=12V: Temp=40 deg
CPUFAN_VCC=11V: Temp=82 deg
CPUFAN_VCC=10V: Temp=70 deg
CPUFAN_VCC= 9V: Temp=110 deg
CPUFAN_VCC= 8V: Temp>200 deg

If use PBSS5240 1pcs : (with airflow)

CPUFAN_VCC=12V: Temp=33 deg
CPUFAN_VCC=11V: Temp=62 deg
CPUFAN_VCC=10V: Temp=86 deg
CPUFAN_VCC= 9V: Temp=117 deg
CPUFAN_VCC= 8V: Temp>122 deg

Intel Confidential

Title		FAN CONTROL	
Size B		Document Number	8GPNXP DUO
Date: 星期四, 五月 20, 2004		Sheet	32 of 49
		Rev	1.01

"\$" means for ALC880 only
 "*" means for CMI9880 only

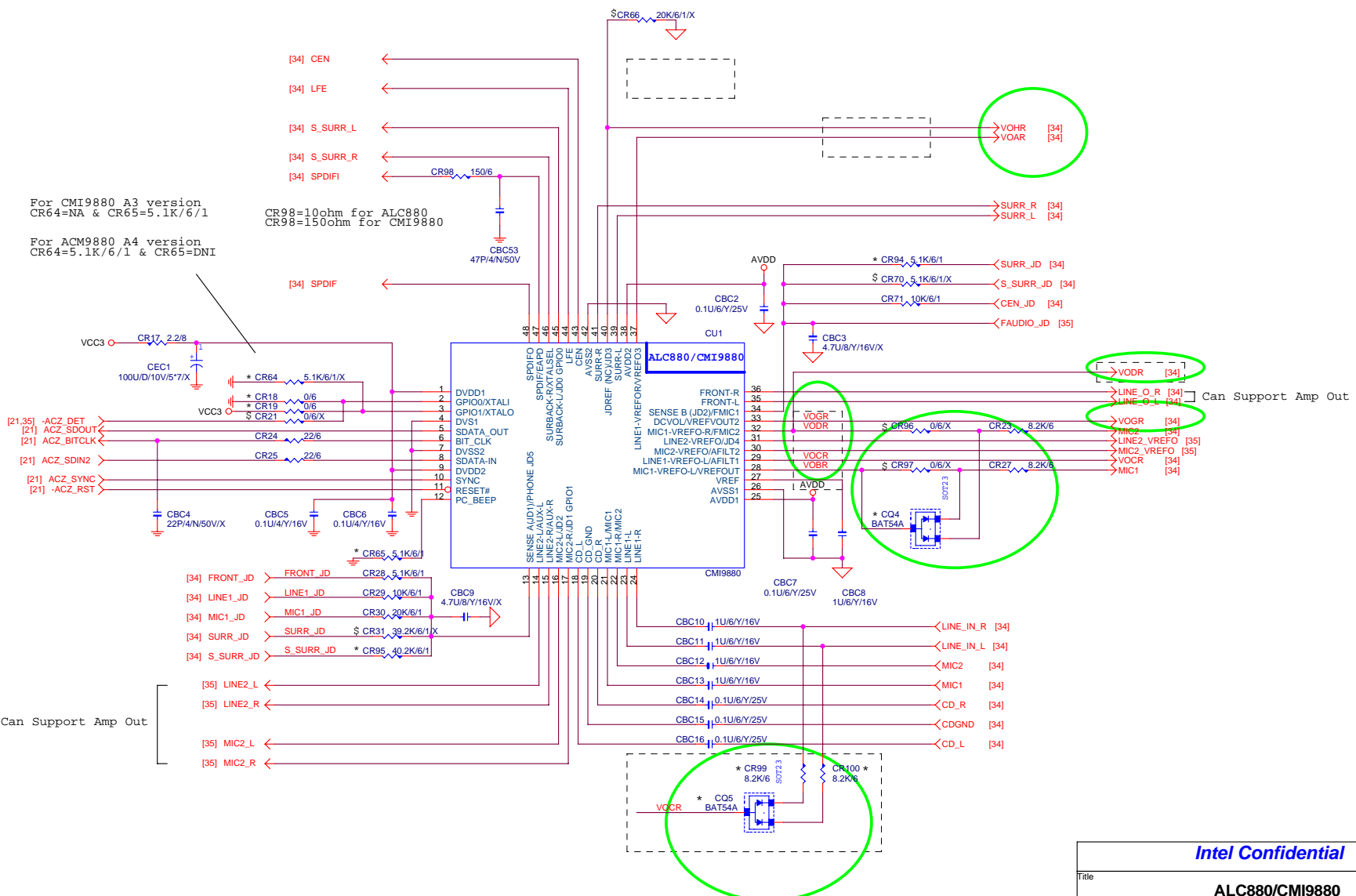

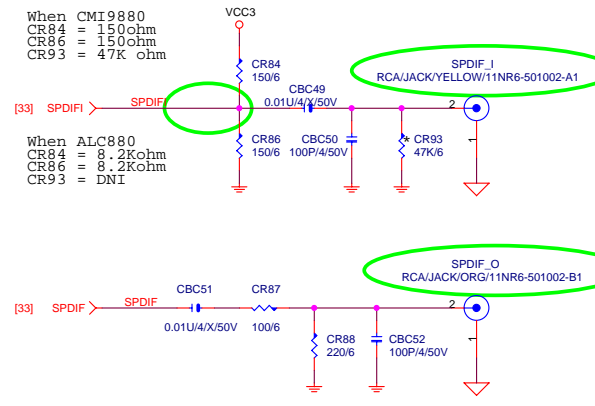
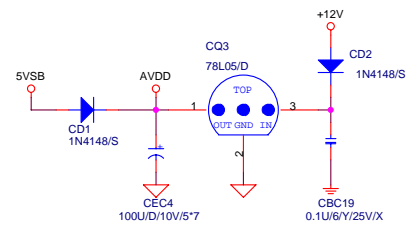
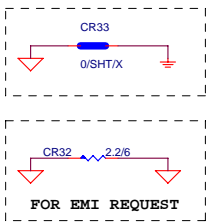

**LINE OUT
FRONT OUT**

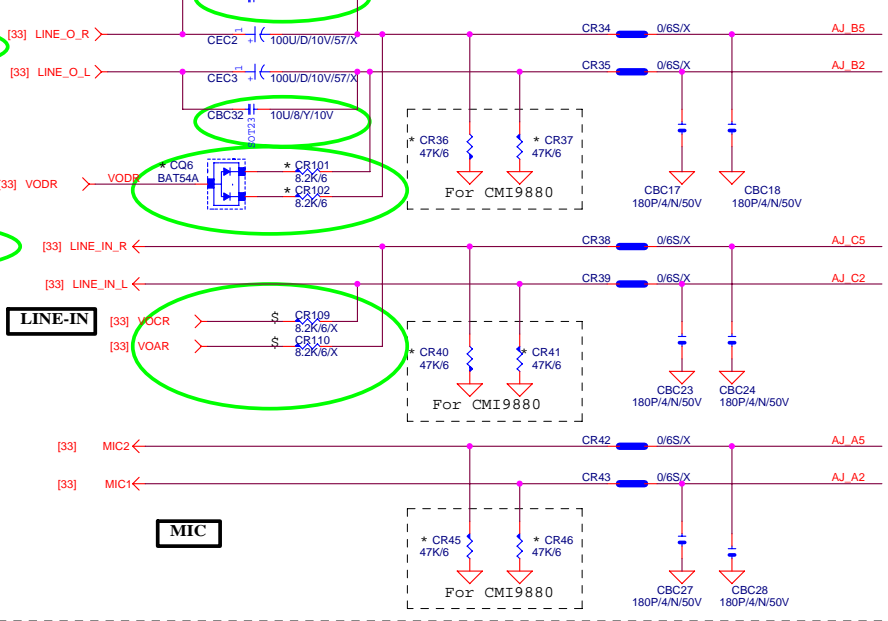

LINE-IN

MIC

CD IN

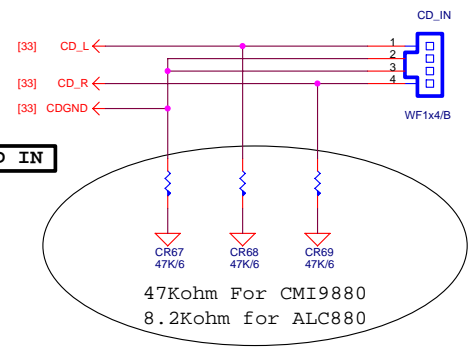

Azalia Jack
Normal --> pin4/pin3 open
Plug jack --> pin4/pin3 close

CMI9880 Port A is Side SURROUND, Port H is Back SURROUND
ALC880 Port A is SURROUND, Port H is SIDE

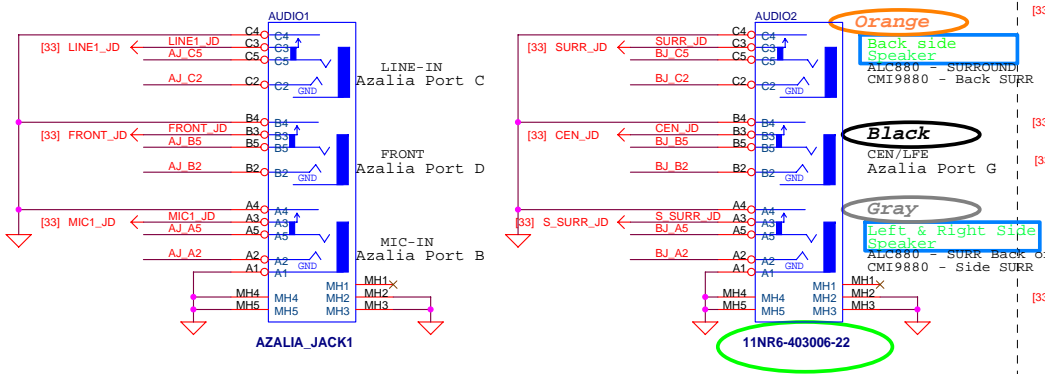

SURROUND

CEN/LFE

SURR BACK

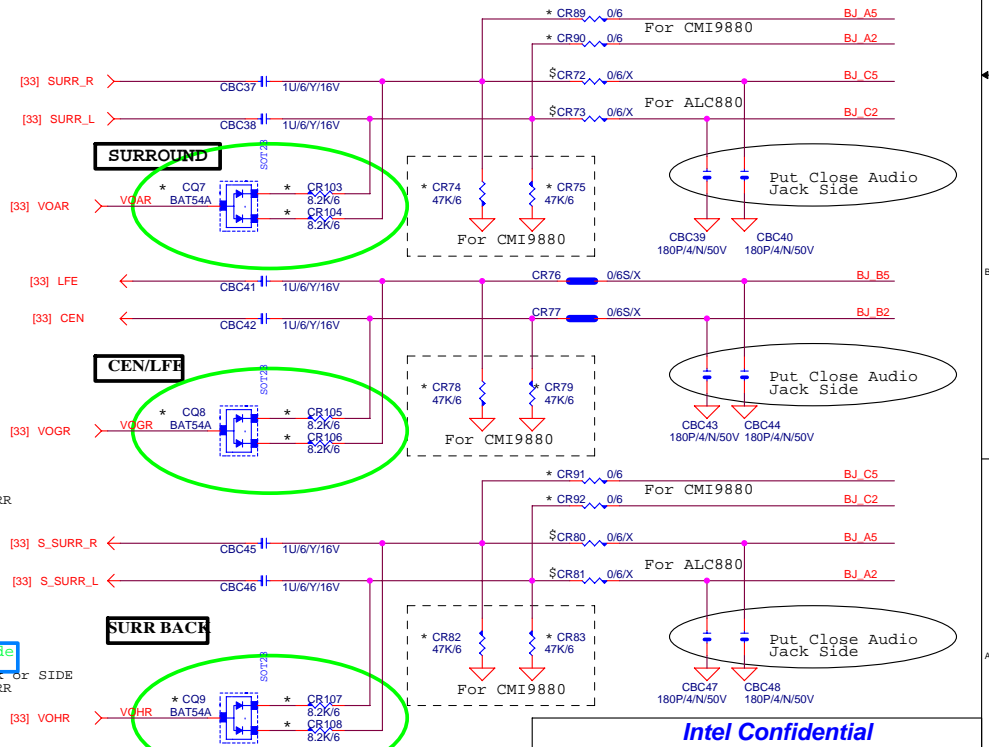

Intel Confidential			
Title	AUDIO JACK 8GPNXP DUO		
Size Custom	Document Number		Rev 1.01
Date: 星期四, 五月 20, 2004	Sheet	34	of 49

Azalia Port F
Azalia Port E

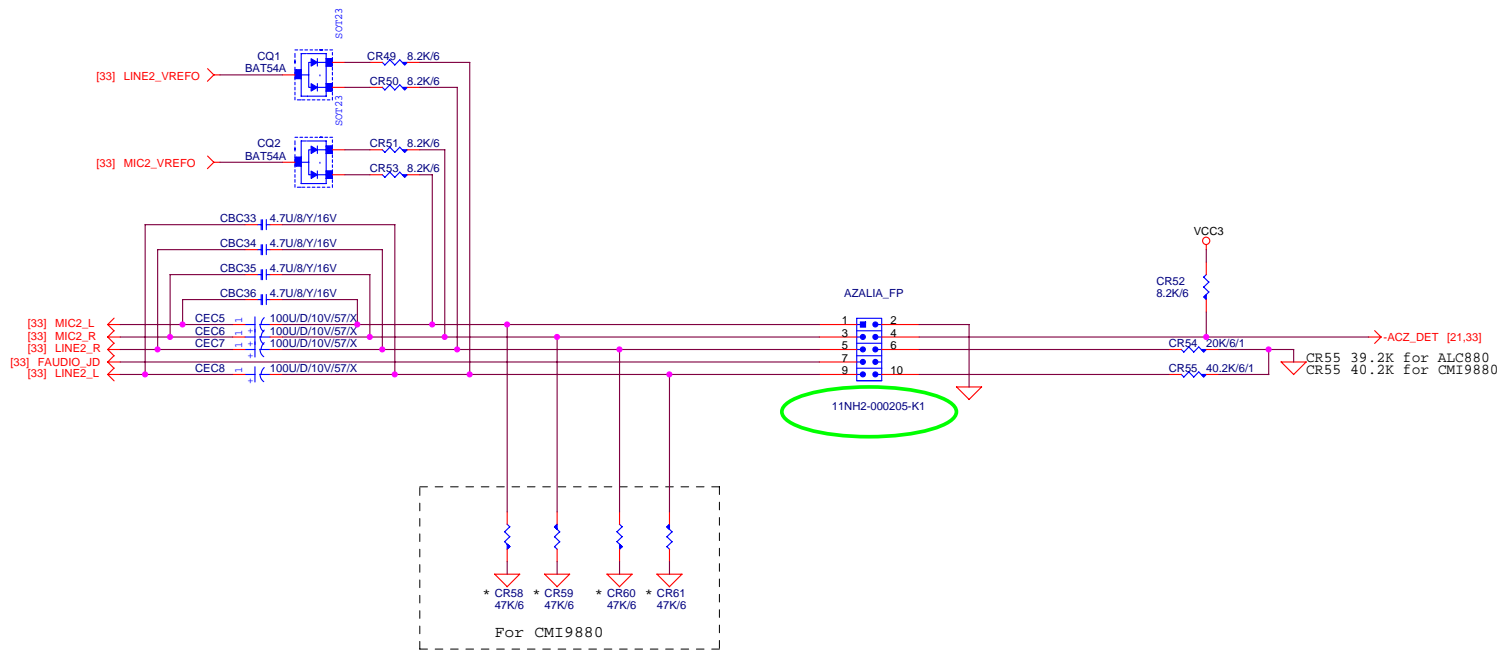

Intel Confidential

Title		FRONT AUDIO CONNECTOR	
Size		8GPNXP DUO	
Custom	Document Number	Rev	1.01
Date:	星期四, 五月 20, 2004	Sheet	35 of 49

Layout Check 注意事項

1. LU1 Pin129 需下內層GND, 打 12 VIA
2. 3VDUAL, VCC3, VDD15_L, AVDD25_L 至少走20mil寬, 並且電容擺設每兩pin至少放一顆Bypass Cap.
3. X'TAL 25MHz 兩訊號線, TRACE 愈短愈好, 線寬12mil
4. MDI正負0-3, TRACE 8:7:8, 每對之間保持 40mil

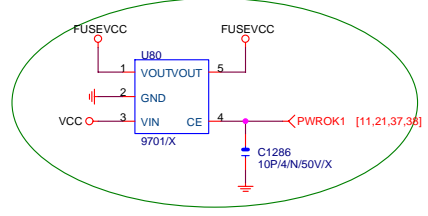

POWER DECOUPLING CAP.

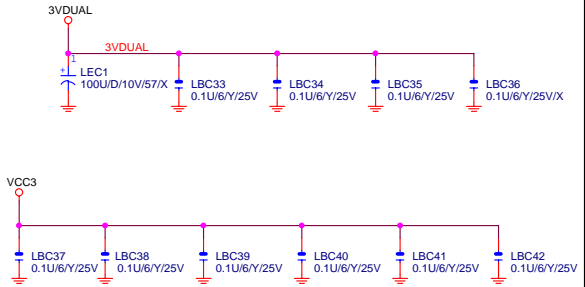

LANCLK33 LBC43 10P/4N/50V/X
-PFMRST2 LBC44 100P/4N/50V/X

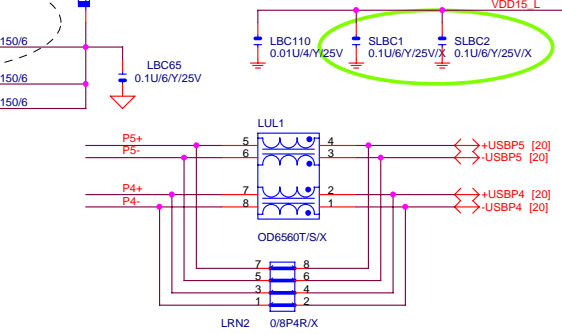
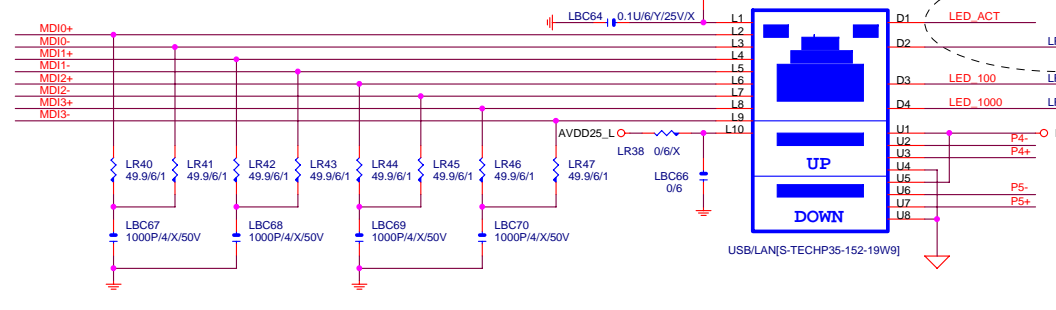
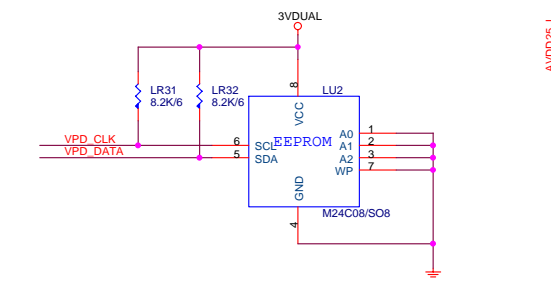
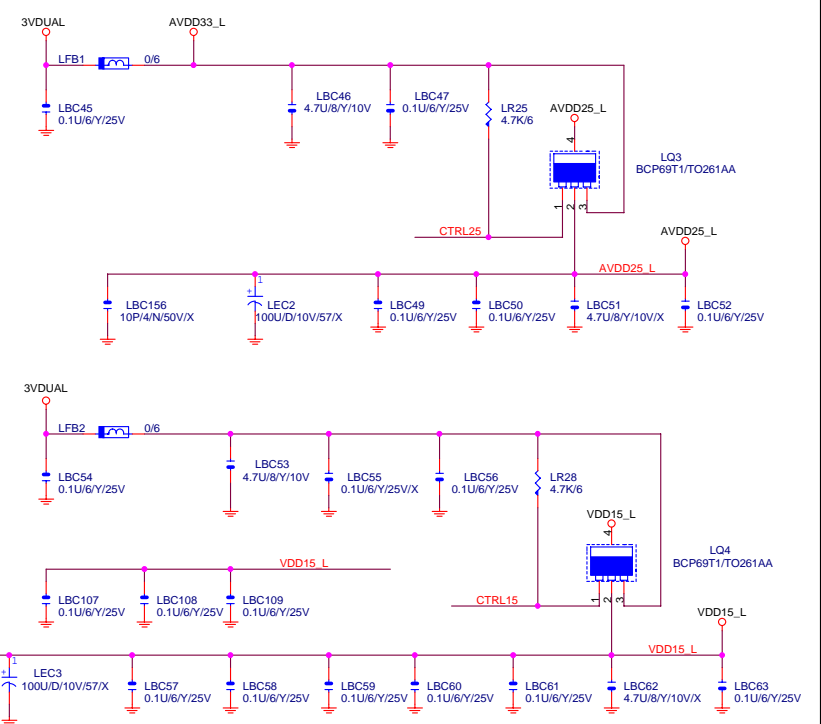
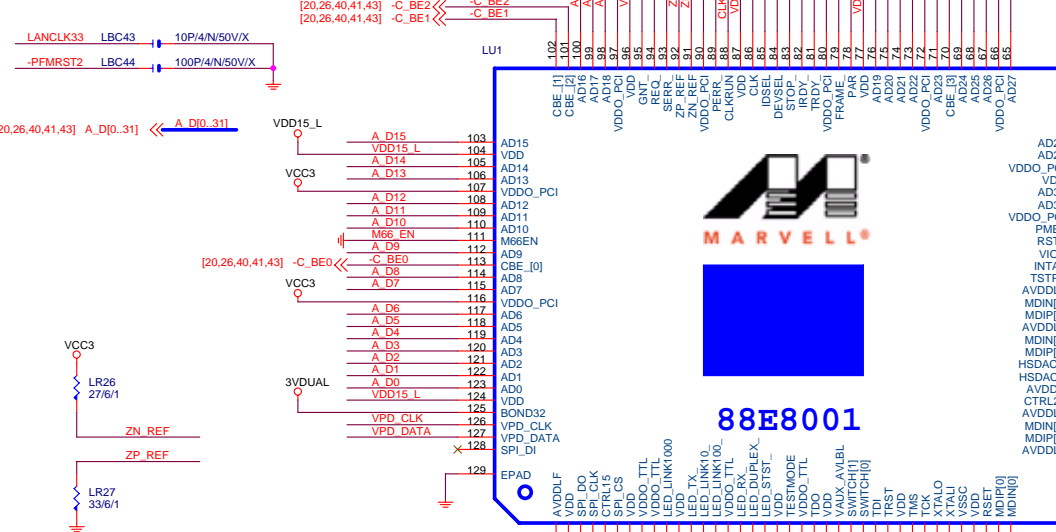

GIGABYTE THCHNOLOGIES, INC.		
Title	MARVELL 88E8001	
Size Custom	Document Number	Rev
	8GPNXP DUO	1.01
Date:	星期四, 五月 20, 2004	Sheet 36 of 49

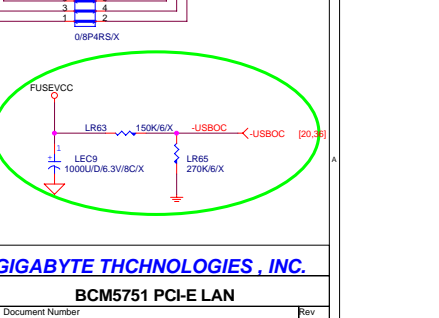
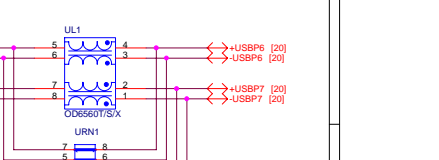
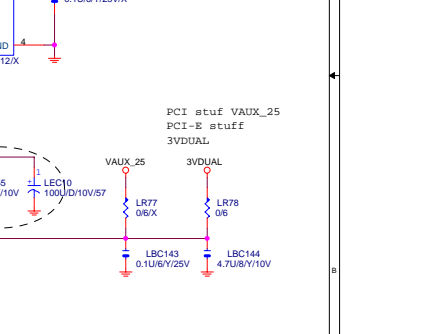
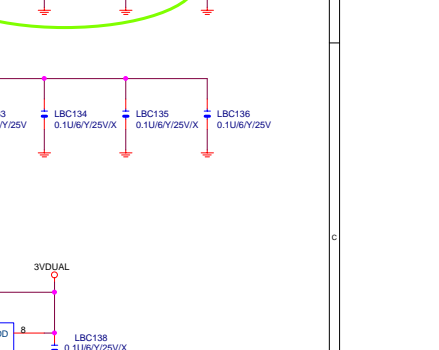
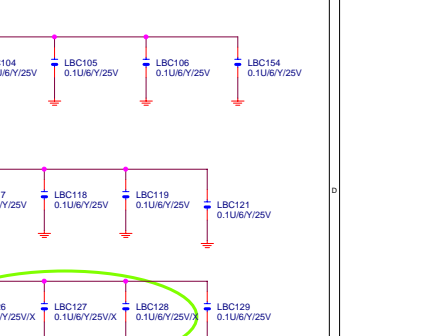
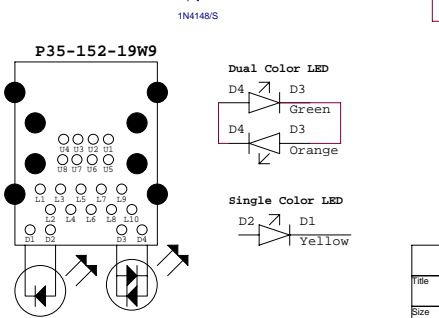
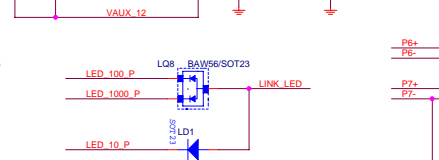
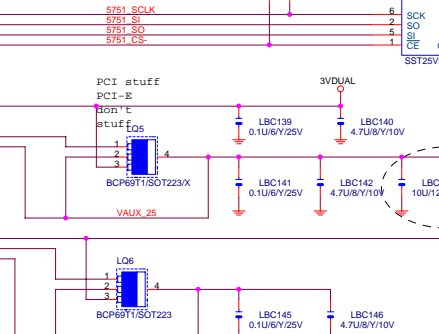
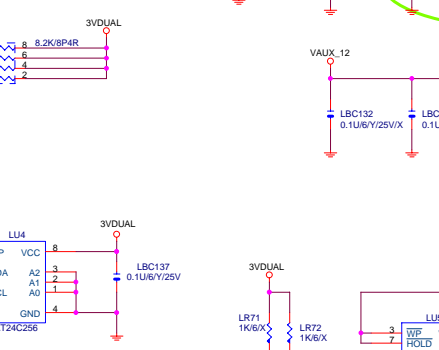
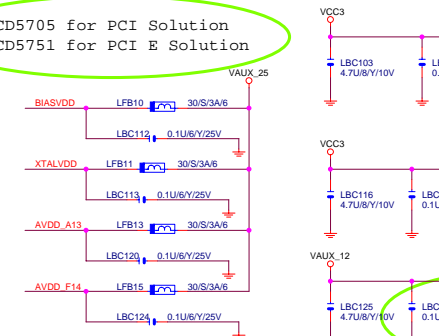
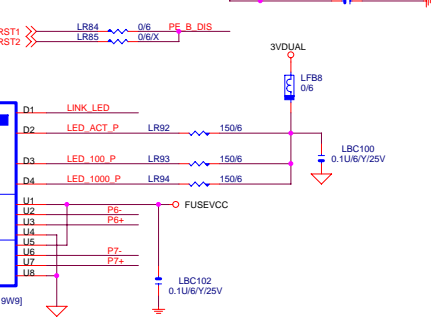
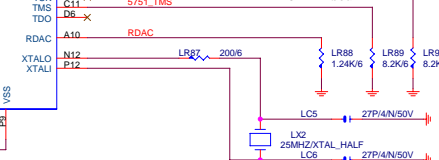
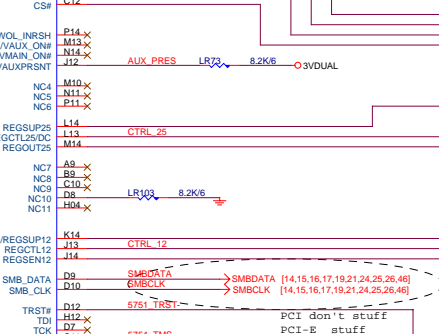
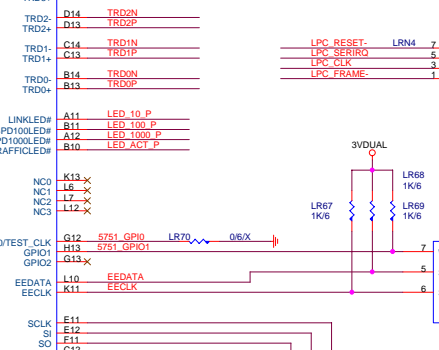
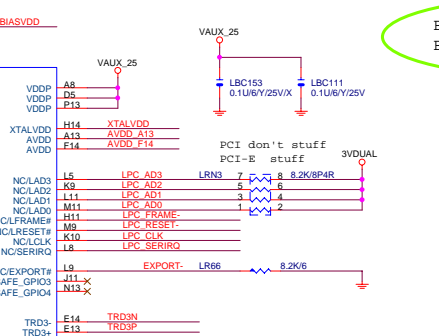
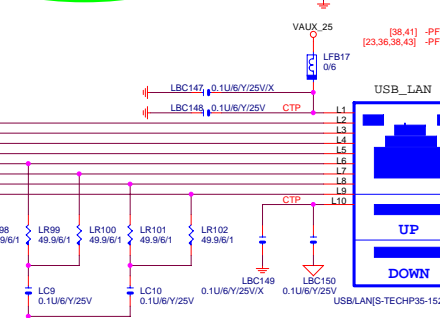
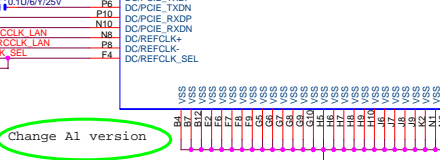
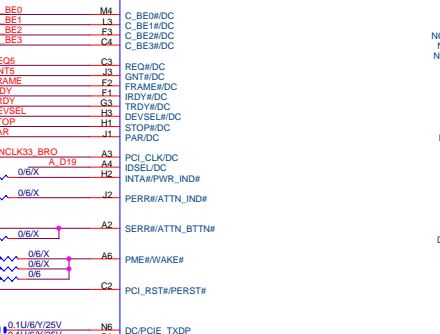
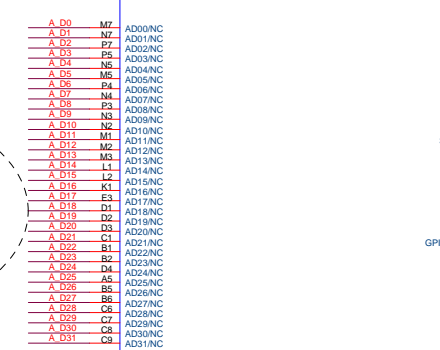
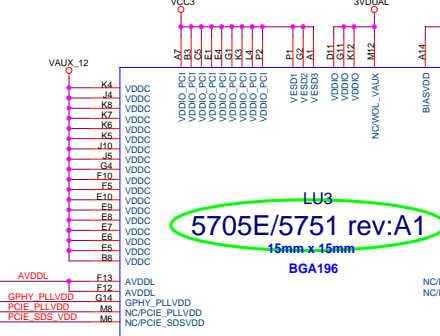
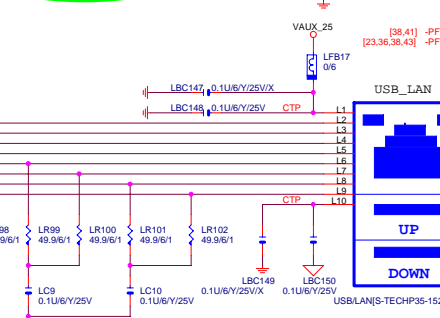
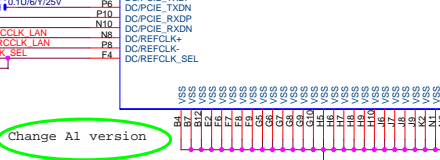
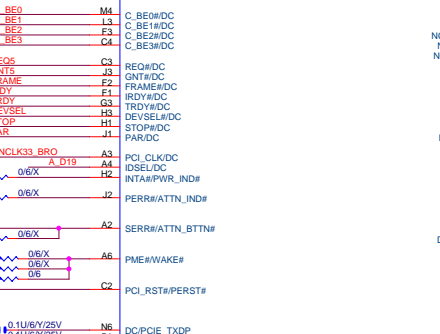
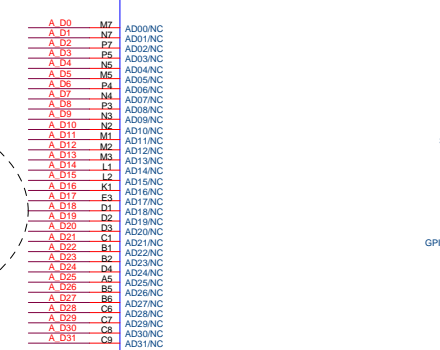
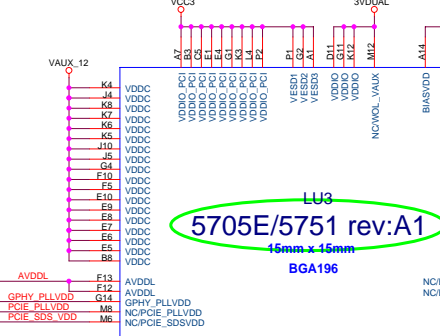
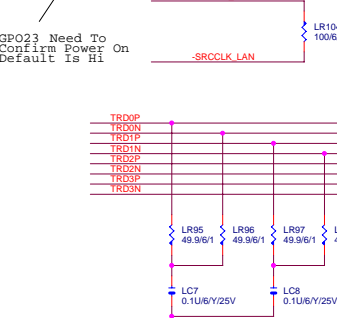
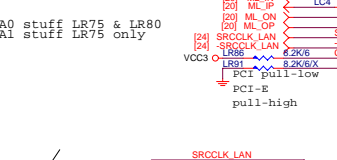
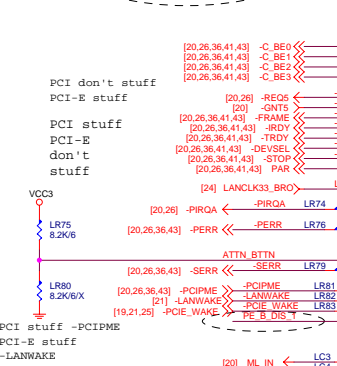
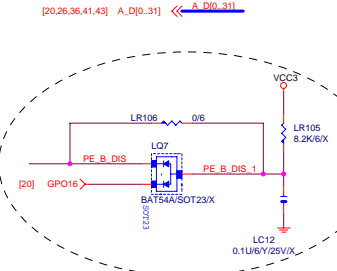
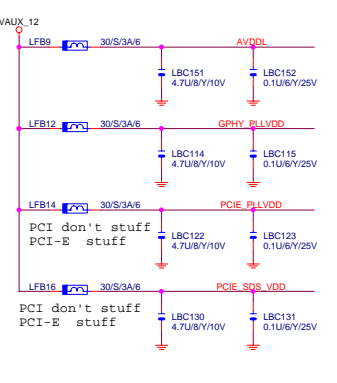

BCD5705 for PCI Solution
BCD5751 for PCI E Solution

LU3
5705E/5751 rev:A1
16mm x 15mm
BGA196

P35-152-19W9

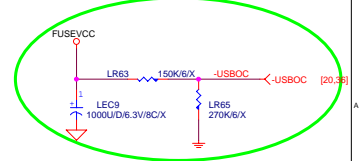
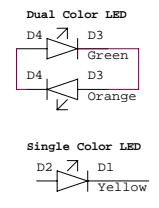

GIGABYTE TECHNOLOGIES, INC.			
BCM5751 PCI-E LAN			
File	Document Number	Rev	
	8GPNXP DUO	1.01	
Size			
Custom			
Date	日期: 2004.12.20	Sheet	40 of 49

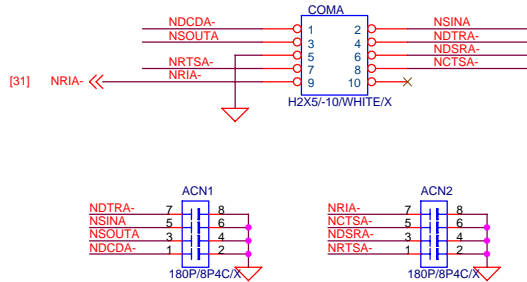
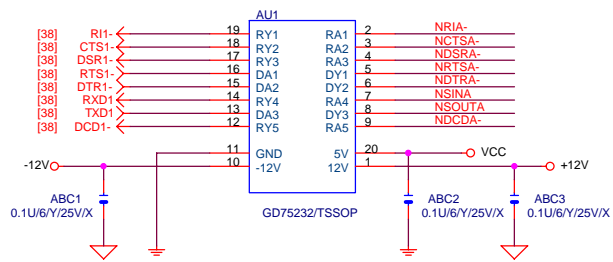

Foot Print Change

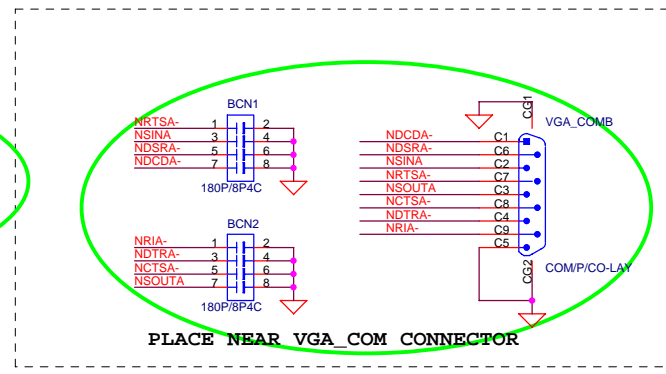
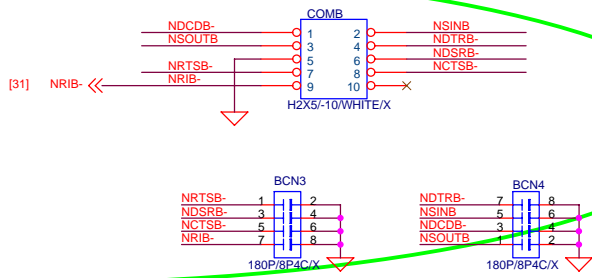
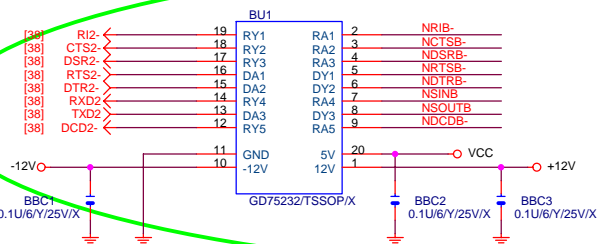

[38] PD[0..7] ↔ PD[0..7]

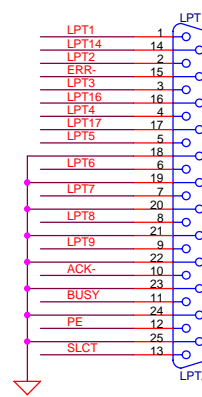
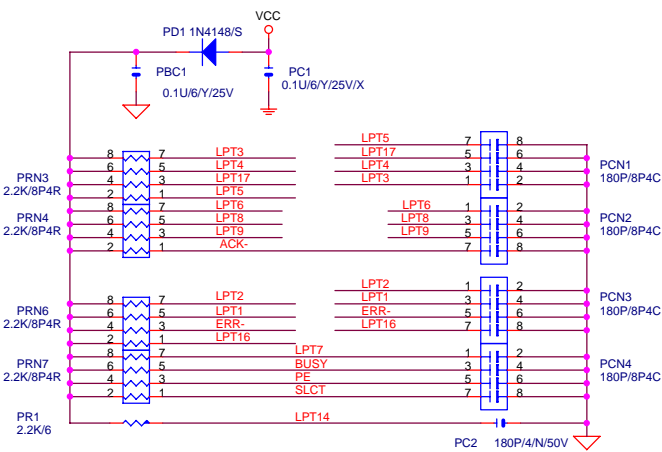
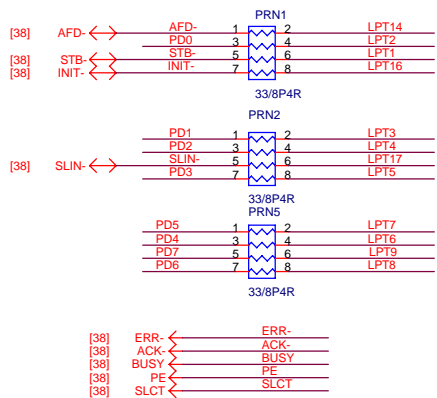

GIGABYTE TECHNOLOGIES, INC.

Title		COM & IR & LPT PORT & FLOOPY	
Size B	Document Number	8GPNXP DUO	
Date:	星期四, 五月 20, 2004	Sheet	40 of 49
			Rev 1.01

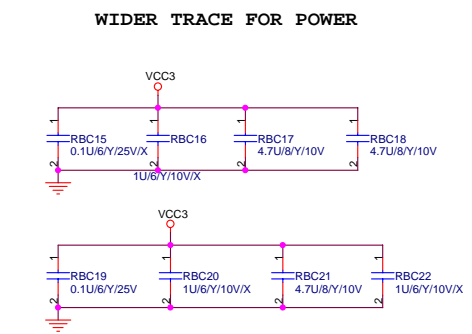
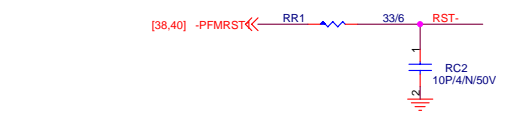
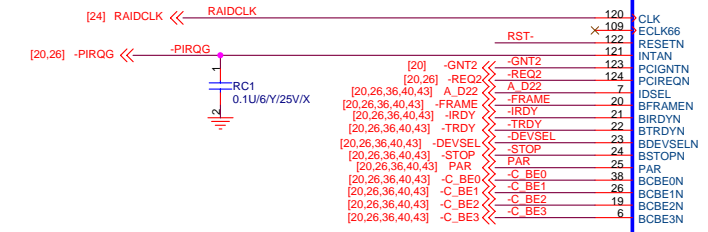
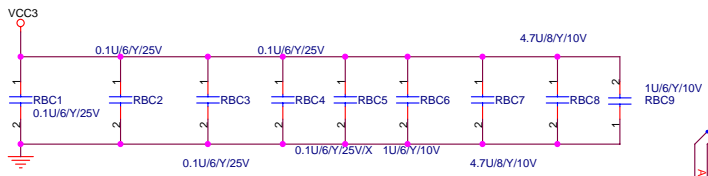

ITE8212F

GIGARAID

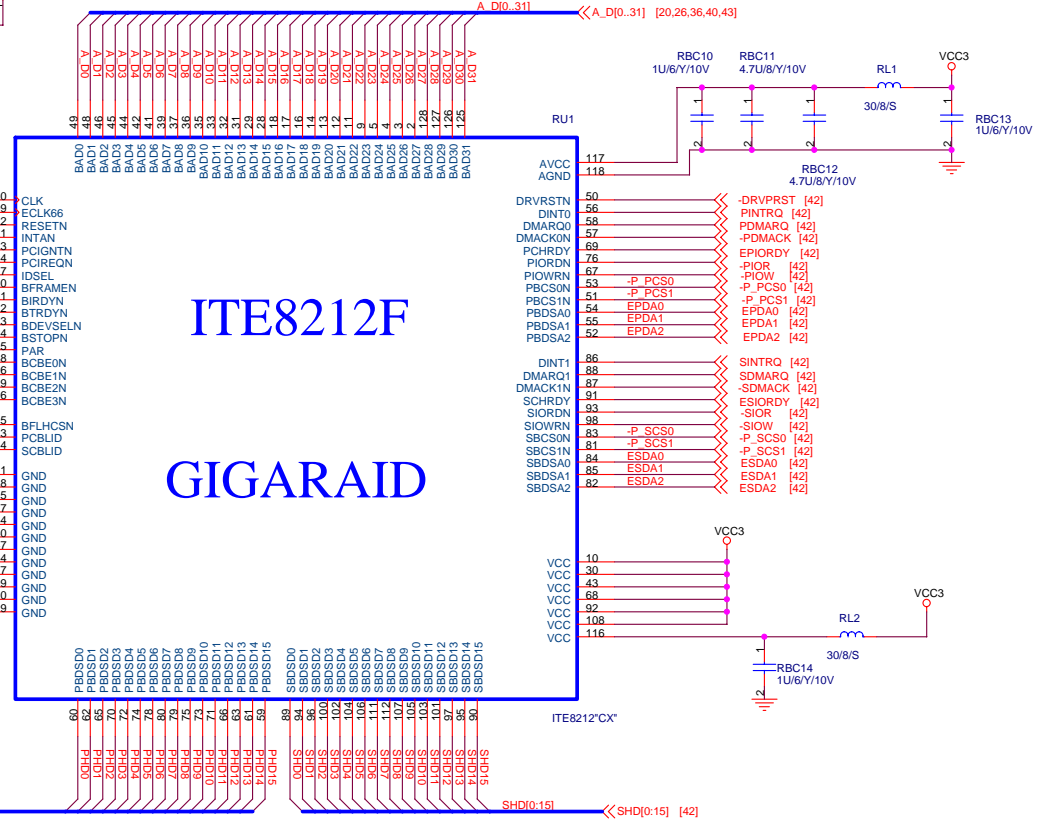

GIGABYTE THCHNOLOGIES, INC.		
Title	ITE GIGARAID	
Size	Document Number	Rev
Custom	8GPNXP DUO	1.01
Date:	星期四, 五月 20, 2004	Sheet 41 of 49

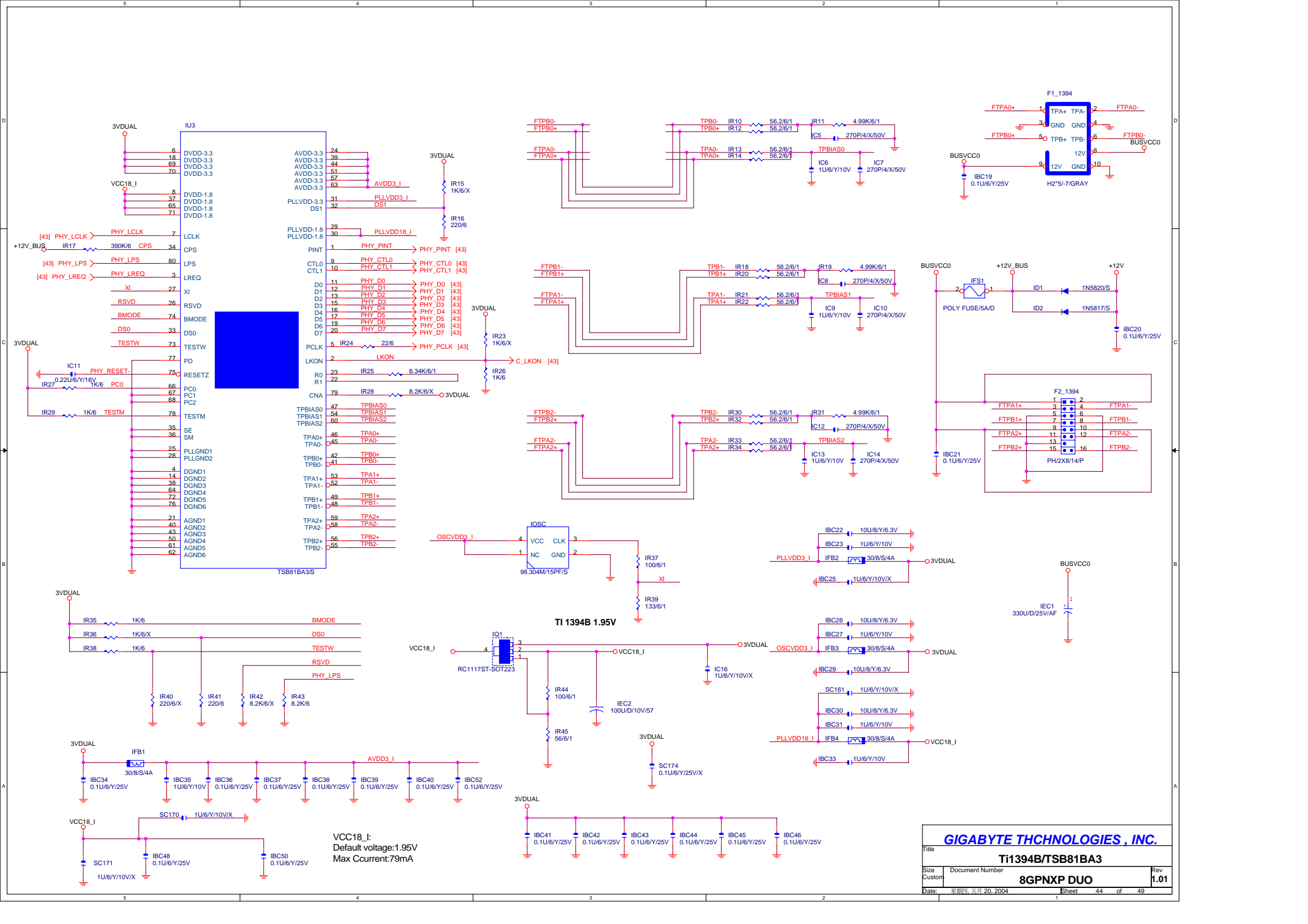

VCC18_I:
Default voltage:1.95V
Max Ccurrent:79mA

GIGABYTE THCHNOLOGIES, INC.		
Title Ti1394B/TSB81BA3		
Size Custom	Document Number 8GPNXP DUO	Rev 1.01
Date 星期四, 五月 20, 2004	Sheet 44	of 49

ATX POWER CONNECTOR

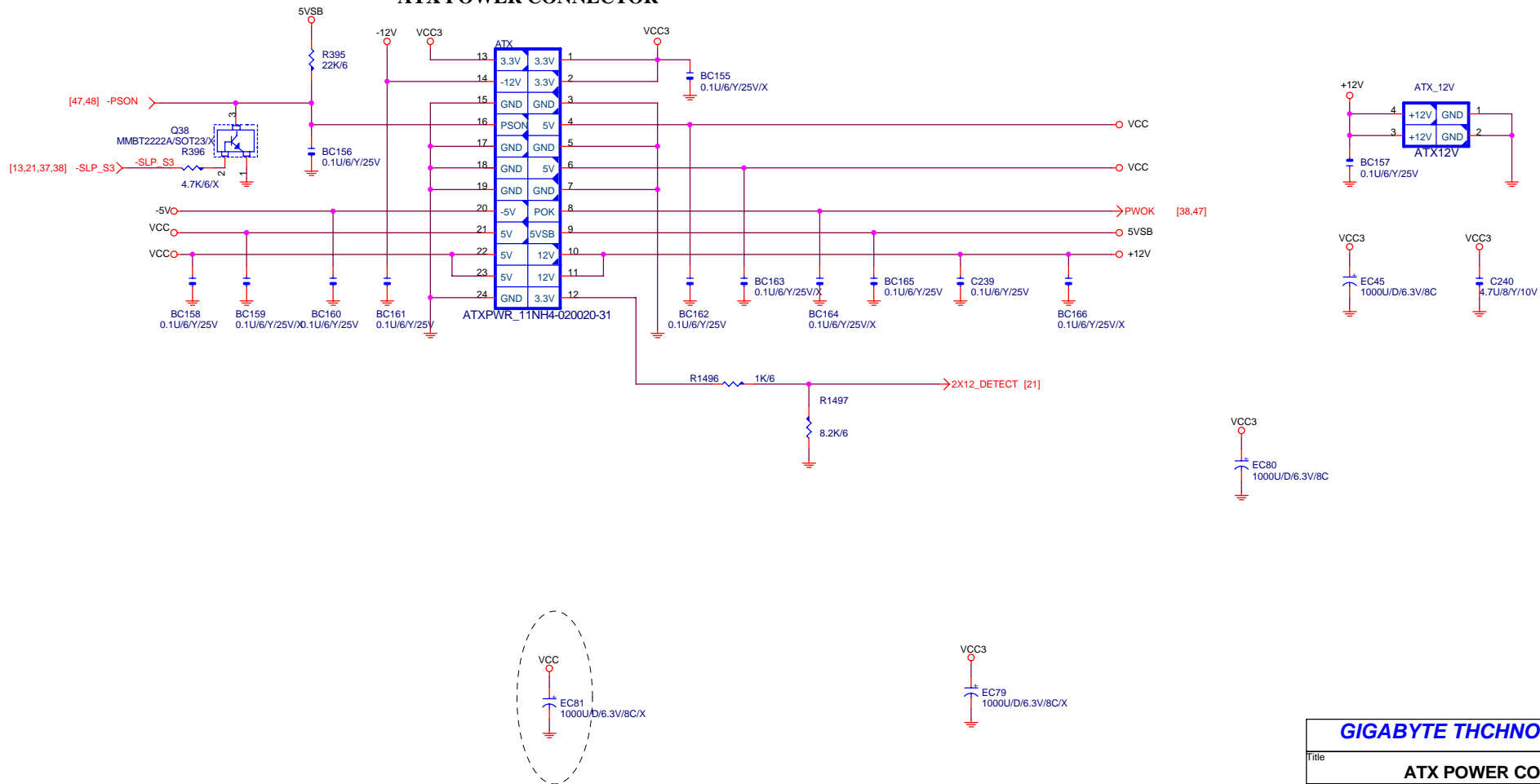

GIGABYTE THCHNOLOGIES , INC.		
ATX POWER CONNECTOR		
8GPNXP DUO		Rev 1.01
Date:	星期四, 五月 20, 2004	Sheet 45 of 49

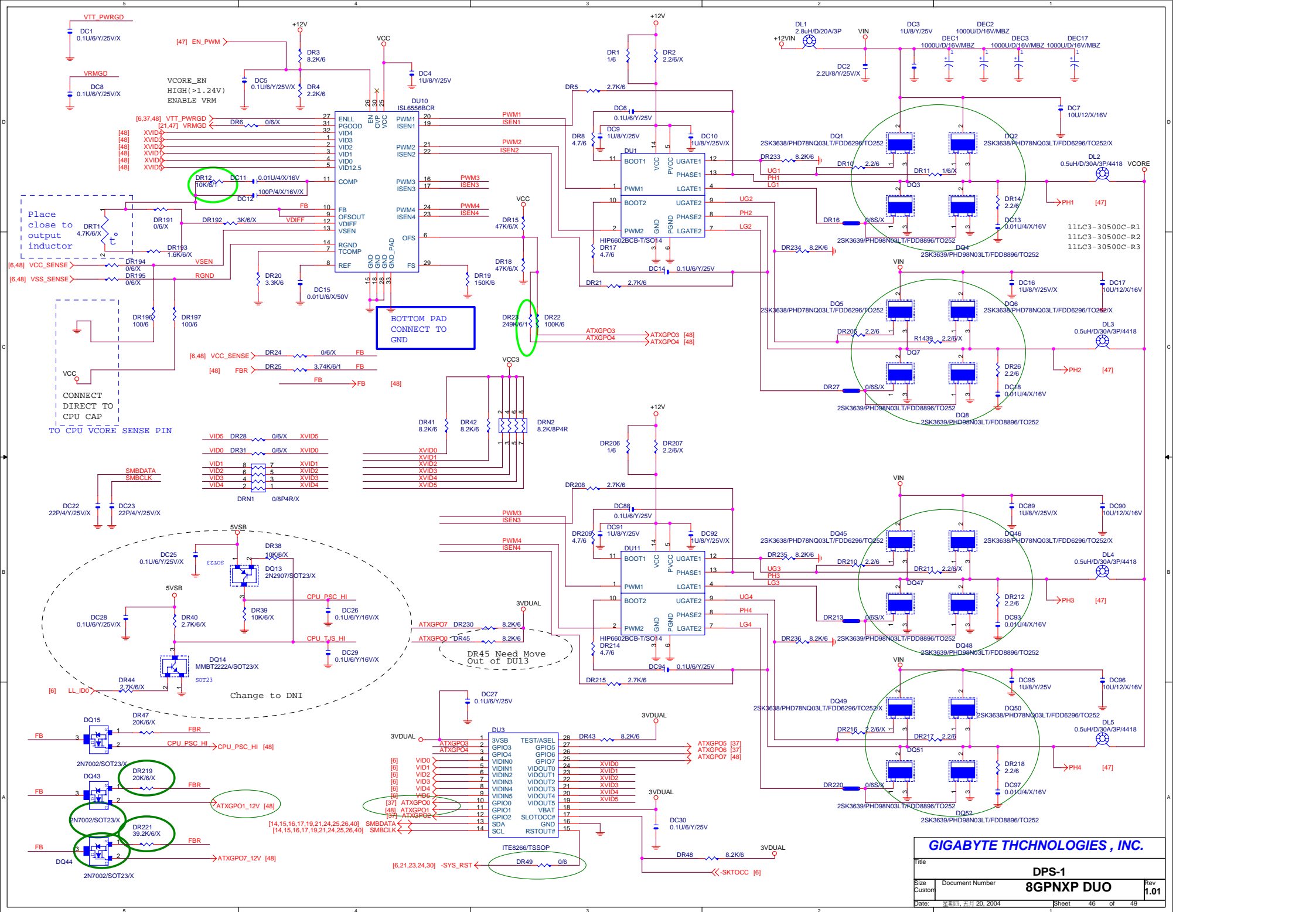

Place close to output inductor

BOTTOM PAD CONNECT TO GND

CONNECT DIRECT TO CPU CAP TO CPU VCORE SENSE PIN

VID5	DR28	0/6/X	XVID5
VID0	DR31	0/6/X	XVID0
VID1	8		XVID1
VID2	6		XVID2
VID3	4		XVID3
VID4	2		XVID4

[6]	VID0	4	XVID3
[6]	VID1	6	XVID2
[6]	VID2	8	XVID1
[6]	VID3	2	XVID4
[6]	VID4	2	XVID4
[6]	VID5	10	XVID5
[37]	ATXGP00	11	
[48]	ATXGP01	12	
[48]	ATXGP02	13	
[48]	ATXGP03	14	
[48]	ATXGP04	15	
[48]	ATXGP05	16	
[48]	ATXGP06	17	
[48]	ATXGP07	18	
[48]	ATXGP08	19	
[48]	ATXGP09	20	
[48]	ATXGP10	21	
[48]	ATXGP11	22	
[48]	ATXGP12	23	
[48]	ATXGP13	24	
[48]	ATXGP14	25	
[48]	ATXGP15	26	
[48]	ATXGP16	27	
[48]	ATXGP17	28	
[48]	ATXGP18	29	
[48]	ATXGP19	30	
[48]	ATXGP20	31	
[48]	ATXGP21	32	
[48]	ATXGP22	33	
[48]	ATXGP23	34	
[48]	ATXGP24	35	
[48]	ATXGP25	36	
[48]	ATXGP26	37	
[48]	ATXGP27	38	
[48]	ATXGP28	39	
[48]	ATXGP29	40	
[48]	ATXGP30	41	
[48]	ATXGP31	42	
[48]	ATXGP32	43	
[48]	ATXGP33	44	
[48]	ATXGP34	45	
[48]	ATXGP35	46	
[48]	ATXGP36	47	
[48]	ATXGP37	48	
[48]	ATXGP38	49	
[48]	ATXGP39	50	
[48]	ATXGP40	51	
[48]	ATXGP41	52	
[48]	ATXGP42	53	
[48]	ATXGP43	54	
[48]	ATXGP44	55	
[48]	ATXGP45	56	
[48]	ATXGP46	57	
[48]	ATXGP47	58	
[48]	ATXGP48	59	
[48]	ATXGP49	60	
[48]	ATXGP50	61	
[48]	ATXGP51	62	
[48]	ATXGP52	63	
[48]	ATXGP53	64	
[48]	ATXGP54	65	
[48]	ATXGP55	66	
[48]	ATXGP56	67	
[48]	ATXGP57	68	
[48]	ATXGP58	69	
[48]	ATXGP59	70	
[48]	ATXGP60	71	
[48]	ATXGP61	72	
[48]	ATXGP62	73	
[48]	ATXGP63	74	
[48]	ATXGP64	75	
[48]	ATXGP65	76	
[48]	ATXGP66	77	
[48]	ATXGP67	78	
[48]	ATXGP68	79	
[48]	ATXGP69	80	
[48]	ATXGP70	81	
[48]	ATXGP71	82	
[48]	ATXGP72	83	
[48]	ATXGP73	84	
[48]	ATXGP74	85	
[48]	ATXGP75	86	
[48]	ATXGP76	87	
[48]	ATXGP77	88	
[48]	ATXGP78	89	
[48]	ATXGP79	90	
[48]	ATXGP80	91	
[48]	ATXGP81	92	
[48]	ATXGP82	93	
[48]	ATXGP83	94	
[48]	ATXGP84	95	
[48]	ATXGP85	96	
[48]	ATXGP86	97	
[48]	ATXGP87	98	
[48]	ATXGP88	99	
[48]	ATXGP89	100	

GIGABYTE THCHNOLOGIES, INC.

Title: **DPS-1**

Size: **8GPNXP DUO**

Document Number: **Rev 1.01**

Date: 星期日, 五月 20, 2004 Sheet 46 of 49

DUAL POWER

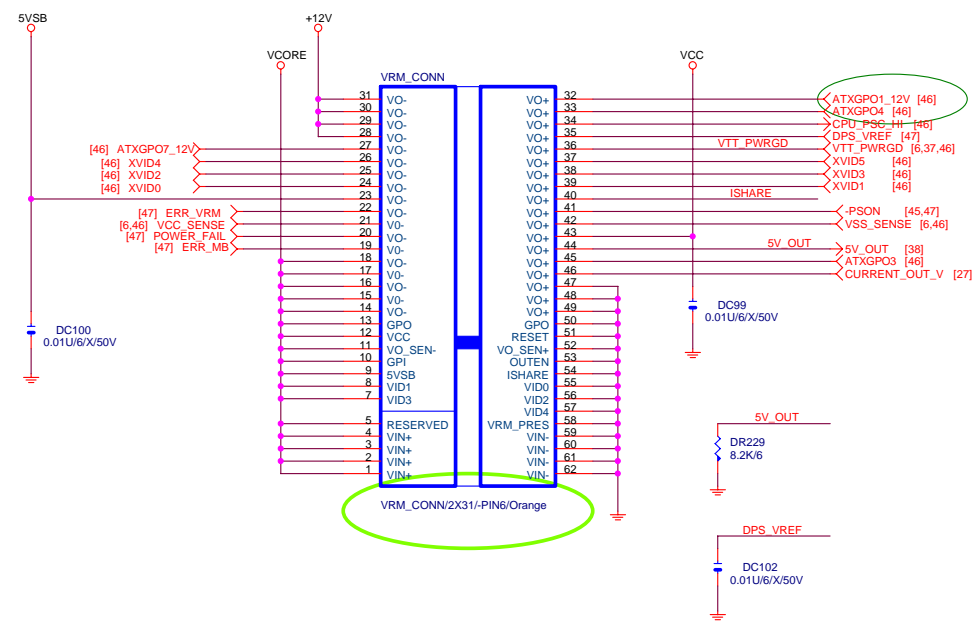
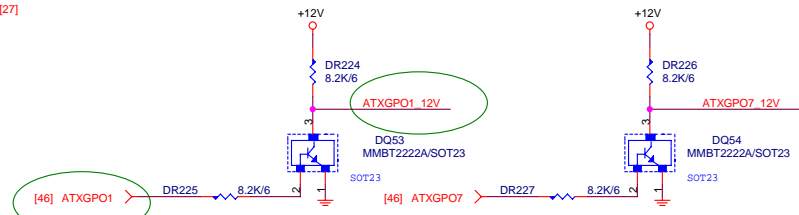
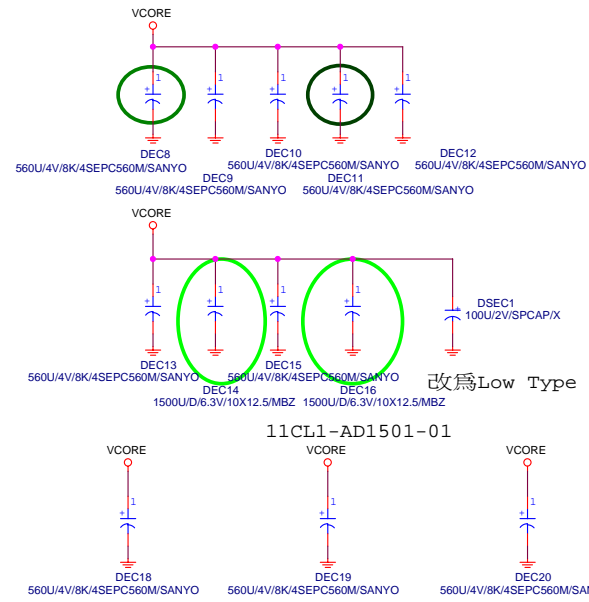
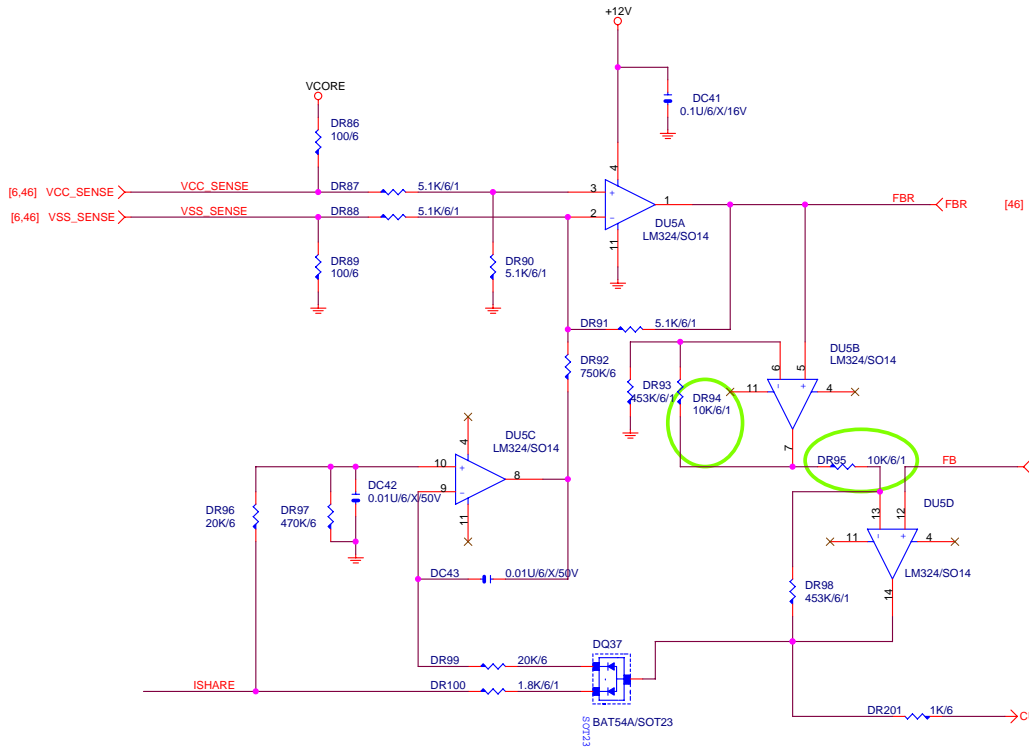

GIGABYTE THCNOLOGIES , INC.		
Title		
DPS-3		
Size	Document Number	8GPNXP DUO
Custom		Rev 1.01
Date:	星期四, 五月 20, 2004	Sheet 48 of 49

ATX PWOK
ICH6 GPIO Table:

NAME	PWR LANE	USAGE	NAME	PWR LANE	USAGE
GPI0	V5REF	M/B ID (-REQ6)	GPI41	VCC3	M/B ID
GPI1	V5REF	-REQ5	GPO48	VCC3	-GNT4
GPI2	V5REF	-PIRQE	GPO49	V-CPUIO	CPUPWOK
GPI3	V5REF	-PIRQF			
GPI4	V5REF	-PIRQG			
GPI5	V5REF	-PIRQH			
GPI6	VCC3	-SLP BTN			
GPI7	VCC3	DUAL BIOS			
GPI8	3VDAUL	-LANWAKE			
GPI9	3VDAUL	-USBOC4			
GPI10	3VDAUL	-USBOC5			
GPI11	3VDAUL	-SMBALT			
GPI12	VCC3	ATX DET			
GPI13	3VDAUL	-LPCPME			
GPI14	3VDAUL	-USBOC6			
GPI15	3VDAUL	-USBOC7			
GPO16	VCC3	CPU OV1 (-GNT6)			
GPO17	VCC3	-GNT5			
GPO18	VCC3	CPU OV2			
GPO19	VCC3	DUAL BIOS			
GPO20	VCC3	BIOS T-BLOCK			
GPO21	VCC3	DUAL BIOS			
GPO23	VCC3	DDR OV0			
GPI024	3VDAUL	GREEN LED			
GPI025	3VDAUL	DDR OV1			
GPI26	VCC3	SATA GP0			
GPI027	3VDAUL	+PWRLED			
GPI028	3VDAUL	-PWRLED			
GPI29	VCC3	SATA GP1			
GPI30	VCC3	SATA GP2			
GPI31	VCC3	SATA GP3			
GPI032	VCC3	BIOS WP			
GPI033	VCC3	AZALIA DET			
GPI034	VCC3	PWRLED			
GPI40	V5REF	-REQ4			

PWOK/RESET Table:

ITE8712BHX PIN	NET NAME	TARGET
PIN62/-PCIRST1	-PCIE_RST	1. PCI-E * 1 Slot1 2. PCI-E * 1 Slot2 3. PCI-E * 1 Slot3 4. PCI-E * 16 Slot
PIN64/-PCIRST2	-PFMRST2	1. Onboard PCI Lan 2. Onboard 1394 Chip 3. OnBoard FWH
PIN65/-PCIRST3	-PFMRST1	1. Onboard PCI-E Lan 2. Onboard SATA Chip 3. GMCH
PIN63/PWROK1	PWROK1	1. GMCH 2. ICH6 3. 5VDUAL SWITCH
PIN109/PWROK2	-THERM	1. ICH6
ICH6 -PCIRST		1. PCI Slot1 1. PCI Slot2
ICH6 -PFMRST		1. GMCH 2. IDE 3. LPC IO 4. 74HC14 Input
ATX PWOK	PWOK	1. LPC IO 2. DPS
PIN115/-PCIRST4	-IDERST	Reserved For IDE

GIGABYTE THCNLOGIES , INC.

Title		GPIO/RESET TABLE	
Size	Document Number	8GPNXP DUO	
Custom			Rev 1.01
Date:	星期四, 五月 20, 2004	Sheet	52 of 49